

MODERNIZE

your WILLIAMSON

by

David Hafler

Dyna Company

REPRINTED FROM AUDIOCRAFT, JANUARY 1956

Modernization of Williamson-type amplifiers can be readily accomplished by use of new components and circuit modifications. These changes improve performance by increasing power handling capabilities and extending the margin of stability. This article describes the modernization procedure for a popular circuit using the new Dynaco A-430 transformer and EL-34 output tubes.

DYNA COMPANY

DYNACO

5142 MASTER STREET
PHILADELPHIA 31, PA.

MODERNIZE your Williamson Amplifier

by DAVID HAFLER

THE Williamson amplifier circuit was first publicized in England in 1947, and in this country in 1949. It has achieved wide acceptance and popularity, and has been the basis for several modifications of the original design. The most basic change was the ultra-linear version of operation, which I developed and subsequently described*. This arrangement corrected 2 of the basic deficiencies in the original design—it increased the power capability of the amplifier to 25 or 30 watts, and it improved the margin of feedback stability.

Now, as always happens, progress in amplifier design has continued: it is possible to make further improvements in the Williamson design (both triode and ultra-linear versions). These improvements again correct for limitations with respect to power output and stability.

Increasing Power Output

Present thinking on requirements for audio power is vastly different from that of a few years ago. Then, most people said, "Ten watts is enough for me." Now, however, modern program material has been increased in dynamic range many times over that of former years. This fact alone has increased the power requirements substantially for realistic, undistorted reproduction. In addition, source material frequency response has been extended, and this also introduces the need for a re-evaluation of amplifier power requirements. Increased frequency response means that the amplifier has to handle power at greater extremes of frequency. At these extremes, the impedance characteristics of the loudspeaker change from the nominal values. This means that the amplifier is *mismatched* at frequency extremes, and a mismatch decreases the maximum-power capabilities of any amplifier.

To deliver clean power into a loudspeaker load, an amplifier must be capable of at least *twice* the power required for a resistor load such as is used in measuring and rating amplifiers. Thus the extension of both dynamic range and frequency range in modern recordings, FM sources, and tape means that 25 watts are about a *minimum* if top-grade

performance is required. Even this minimum will probably be increased in the years to come unless the efficiency of loudspeaker systems can be increased.

For these and related reasons, efforts have been devoted to increasing the power output of audio amplifiers. The advent of some new tube types has made this practical within the Williamson configuration without the need for completely rebuilding the amplifier. Changes required are replacement of the output tubes, substitution of an output transformer which will handle the increased power and provide suitable impedance matching, and addition of fixed bias.

New Output Tubes

The new tube selected for modernization of the Williamson is the Amperex 6CA7, which is also imported and distributed as the Mullard EL-34. This is a compact tube with power capabilities up to 100 watts, depending on the supply voltages available. It can be plugged directly into the sockets formerly used for 5881's, KT66's, 1614's, and other tubes of this type, with the single additional requirement that the No. 1 pins must be grounded.

The 6CA7/EL-34 is a pentode tube

of extreme linearity. Its preferred operating condition is as a pentode: although the manufacturer furnishes triode ratings for the tube, triode operation results in higher distortion and reduced power output. The conventional ultra-linear connection cannot provide optimum results with these tubes either, since there is no type of operation more linear than the pentode connection for which they were designed. As will be discussed later, however, a compromise form of operation fits the needs of the Williamson modernization very nicely.

To derive the potential benefits available in these tubes, proper impedance matching must be obtained in the output transformer. The Dynaco A-430 transformer has been designed specifically for this purpose. This is a 50-watt unit, the performance of which exceeds Mr. Williamson's specifications with respect to frequency response, permissible feedback, power handling ability, and so on. At present this is the only commercial transformer of correct impedance, but it is anticipated that others may be available soon.

The Dynaco A-430 has primary taps which can be used to furnish about 10% screen loading. This does not cause de-

Fig. 1. Complete circuit diagram of a Williamson amplifier modified as described.

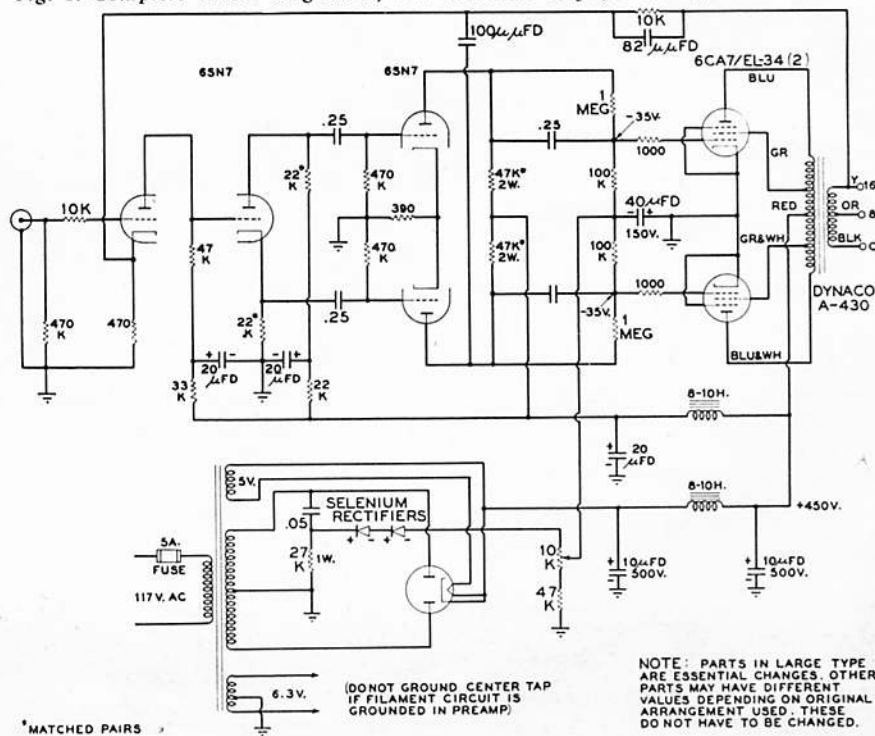

*Hafner, D., and Keroes, H. I., "Improving the Williamson Amplifier", *Radio & Television News*, February 1953.

*MATCHED PAIRS

NOTE: PARTS IN LARGE TYPE ARE ESSENTIAL CHANGES. OTHER PARTS MAY HAVE DIFFERENT VALUES DEPENDING ON ORIGINAL ARRANGEMENT USED. THESE DO NOT HAVE TO BE CHANGED.

THE FINEST COMPONENTS

All premium components are used in the DYNAKIT to insure permanence of characteristics without failures and to provide neat clean appearance. Some of these "extra" features which are normally only available in custom built equipment are:

- DYNACO A-430 output transformer. This unit sells separately from the kit for \$29.95 net. It is the finest of its type
- A heavy duty, conservatively rated power transformer with capacity to power a pre-amplifier if desired
- Ceramic cased and plastic paper capacitors
- 500 volt specially formed electrolytic capacitor
- 1000 volt mica capacitor
- Dependable highly linear EL-34/6CA7 tubes
- Heavy duty rectifier tube
- XXXP etched circuit board with parts mounted and dip soldered. Metal eyelets for external connections to eliminate strain on plated wiring.
- Underwriter approved line cord
- On-off switch
- "Wired in" fuse
- Bias setting control
- Nickel plated, binder (flat) head screws
- High temperature insulation, solid hookup wire
- Spot welded heavy gauge chassis
- Protective cover and bottom plate
- Spare socket for pre-amp power, remote on-off switching, etc.

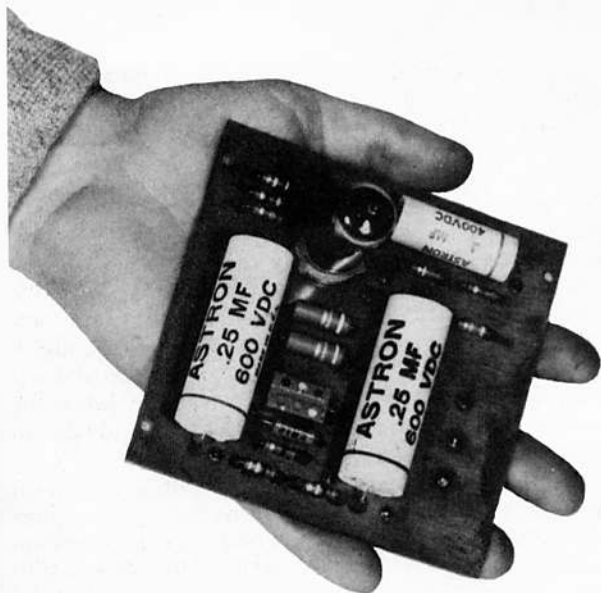

THE EASIEST TO ASSEMBLE

The use of the pre-assembled printed circuit board eliminates two-thirds of the work. An inexperienced constructor can figure on about three hours of enjoyable and interesting assembly time in mounting parts and soldering the connections. The work is simplified by detailed point-by-point instructions included with the DYNAKIT and by two-step pictorial diagrams which show the placement of every lead and every part.

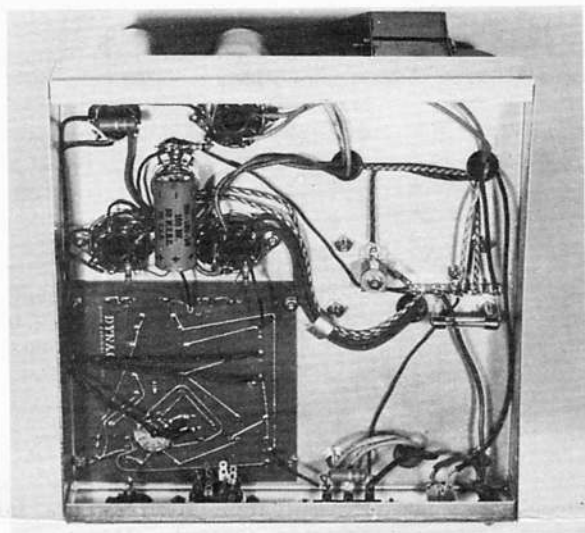

THE DYNAKIT'S PERFORMANCE

The measured specifications show that the DYNAKIT rates with the very best of amplifier equipment in the highest price brackets. What these specifications cannot show, however, is how the DYNAKIT amplifier sounds. The clarity, crispness, and smoothness that are attained because of its low distortion, high stability, and superior transient response can only be described through demonstration and comparison with other equipment.

The person who uses a DYNAKIT amplifier will find that familiar music has less stridency and harshness at high frequencies and less muffled quality in the lower frequency passages.

Percussive sounds will have more "snap" while strings will have a more natural sheen. Distortion which was formerly attributed to record breakup or to speaker overload will vanish when the 50 watt DYNAKIT replaces a lower powered amplifier. The advantage of the large power reserve shows up most readily in reproducing large choral works and massive string ensembles, and yet even solo instruments will be reproduced more naturally because of the performance attributes of the DYNAKIT amplifier. We believe that the DYNAKIT Mark II provides listening quality unequalled by any amplifier regardless of price, size, or degree of complexity.

stability are important design problems.

By these standards, then, original Williamson amplifiers have inadequate stability at both extreme low and high frequencies. This can be demonstrated for the low end by touching the input grid momentarily with the fingertip and watching the speaker cone. The heavy low-frequency transient which is generated triggers the amplifier, and there are usually several surges before the effect is damped out. The speaker cone can be observed to move back and forth several times before coming to rest. This means that short signal impulses will also cause spurious cone movements which tend to blur the sound.

At high frequencies, the corresponding effect can be viewed on an oscilloscope with a square-wave signal input. A rippled square wave is indicative of basic instability, and indicates that there is a transient distortion of high-frequency signals.

Instability is due to the fact that the phase characteristics of the amplifier cause some of the feedback to be applied *positively* instead of *negatively* at the frequency extremes. The remedy is superficially simple—to shift the phase in the right direction at the critical frequencies. It is not always simple to do this. Fortunately, the phase characteristics of the A-430 transformer and the Williamson circuit arrangement permit complete correction of the low-frequency phase characteristic and appreciable correction of the high-frequency characteristic. These corrections are made with a few inexpensive components.

The low-frequency correction is achieved by shunting the $0.25\text{-}\mu\text{fd}$ coupling capacitors which go to the output grids with 1 megohm resistors. High-frequency correction is obtained with a $100\text{-}\mu\text{fd}$ capacitor which is connected from the lower driver plate to the cathode of the first stage. Without going into the theory underlying these corrections, it is worth mentioning that they have a tremendous effect on performance. (It is assumed that the 10,000-ohm resistor in the input grid, change of the $.05\text{-}\mu\text{fd}$ capacitors to 0.25, and the use of a small capacitor across the feedback resistor as indicated in the schematic are already included in the amplifier. If not, these should also be added in accordance with previous recommendations*.)

This completes the modernization of the Williamson. If the power supply puts out a full 450 volts with reasonable regulation, the output power will be about 50 watts at 1% IM distortion. If the power supply provides lower voltage, the output power will be reduced somewhat. Below full output, the distortion drops

rapidly toward a vanishing point. The frequency response of the amplifier will be approximately the same as that of the original version except that peaks in the response (associated with instability) are eliminated. The transient response—that unmeasurable intangible—will be audibly better. It will be particularly evident in more solid, better-defined bass and smoother, cleaner treble.

Appendix

The following specific hints will be helpful to those who are interested in modernizing the Heathkit W-3M Williamson:

The bias voltage divider and rectifier can go in the power supply chassis. Output of the selenium rectifier is connected to pin 5 of the power socket and carried through the spare wire in the connecting cable to one side of the 10,000-ohm bias-setting pot.

The 250-ohm and two 100-ohm resistors are discarded, as is the 100-ohm pot. The bias pot replaces the 100-ohm balance adjustment, and the blank tie points to which the 100-ohm resistors were fastened can then be used to connect leads which are part of the ground circuit.

In the interests of economy, the $20\text{-}\mu\text{fd}$ capacitor which formerly by-



passed the cathodes can be used for filtering the bias supply. The schematic calls for $40\text{ }\mu\text{fd}$, but the difference in hum level is only 2 db.

Jacks formerly used for metering plate current can still be used to check equality of the output tubes. The former connection to the 250-ohm bias resistor must now be grounded in order to complete the circuit path for the cathode current. At the same time the No. 1 pins (suppressor grids of the output tubes) should be connected at the socket to the No. 8 (cathode) pins.

In order to insert the 10,000-ohm parasitic suppressor resistor directly at the input grid, the 2.2-megohm resistor should be reconnected directly from the input socket to ground. The 10,000-ohm resistor can then be inserted from the input connector to pin 1 of the first 6SN7 tube. This replaces the $.05\text{-}\mu\text{fd}$ capacitor which is used as part of the bias supply in the power chassis. Make sure that the preamplifier used has an output coupling capacitor since the amplifier now has none in the input. Practically all preamplifiers are so

equipped; if not, one should be added.

The $.05\text{-}\mu\text{fd}$ coupling capacitors between the two 6SN7's should be increased to $0.25\text{ }\mu\text{fd}$. Care should be exercised in order to get these to fit the space. If difficulty is encountered, it is suggested that miniature capacitors be used, such as Aerolites made by Aerovox.

The 1-megohm phase-correcting resistors across the coupling capacitors permit some positive DC to appear on the grids if the negative bias supply is inoperative. The existence of negative voltage at the grid should be checked with the rectifier removed before permitting the B+ voltage to be applied. Then the rectifier should be inserted and the bias set to 35 volts from grid to ground *after* the tubes have had time to warm up. Do not remove the second 6SN7 while the amplifier is on, because this will cause additional positive voltage to be applied to the grids of the output stage, upsetting the bias and possibly harming the tubes.

AUDIOCRAFT Test Results

The amplifier shown in Figs. 2 and 3, which was the basic Williamson converted in accordance with this article, produced 0.6% IM distortion at 50 watts output, 0.2% at 36 watts, and 0.1% at 15 watts. Below 15 watts distortion was in the residual range of the meter and could reasonably be called negligible if not unmeasurable. Test frequencies were 60 and 7,000 cps, mixed in a 4-to-1 ratio.

These readings could have been improved slightly by using parts matched more precisely, or by adding to the power supply filtering. It is doubtful that such small improvement would be apparent audibly. On the other hand, if the phase inverter balance were off, or certain other elements had drifted in value, the distortion figures might be doubled—still exceptionally good performance.

Frequency response was perfectly flat within the range of our test equipment. Calculated response, without the $100\text{-}\mu\text{fd}$ feedback capacitor at the driver stage plate, is ± 1 db from 2 to 200,000 cps; with this added, response above 80,000 cps slopes off smoothly. This capacitor causes a very slight increase in distortion at 20,000 cps, which is quite insignificant compared to the 12 db increase in the high-frequency stability margin. Stability at the low end, determined by recovery characteristics from a sharp overload pulse, was apparently perfect.

Square-wave response at low frequencies was excellent, and exceptionally good at high frequencies. Power response was completely flat from 20 to 20,000 cps at 50 watts. Total cost for all parts required to make the complete conversion: less than \$40.00.

*Hafler, D., "A 60 Watt Ultra-Linear Amplifier", *Radio & Television News*, February 1955.