



For more Hi-Fi manuals and set-up information
please visit www.hifiengine.com

McIntosh

MAC 1900

AM/FM SOLID STATE STEREO RECEIVER

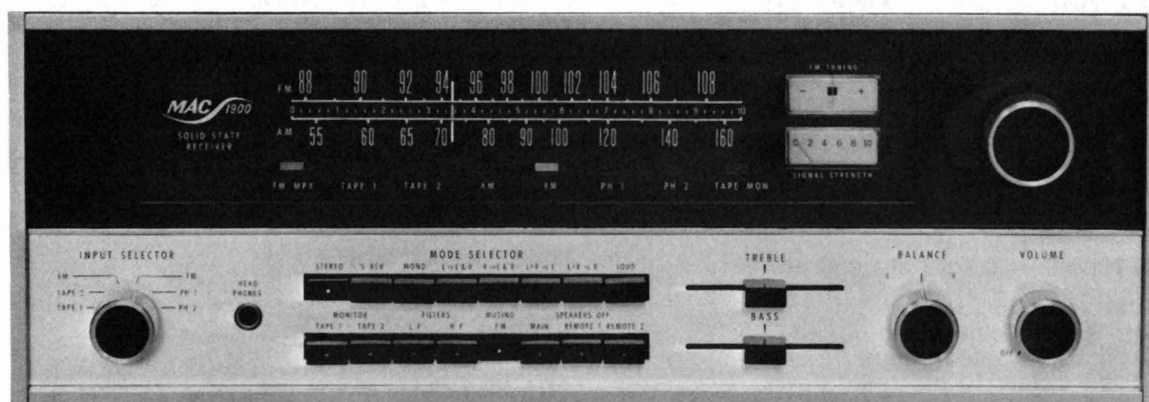

SERVICE INFORMATION

FROM SERIAL NO. 4X230 TO AL9999

PERFORMANCE

McIntosh audio power ratings are in accordance with the Federal Trade Commission Regulation of November 4, 1974 concerning power output claims for amplifiers used in home entertainment products.

POWER OUTPUT

55 watts minimum sine wave continuous average power output, per channel, both channels operating into 8 ohm load impedance, which is:

29.98 volts RMS across 8 ohms

30 watts minimum sine wave continuous average power output, per channel, both channels operating into 16 ohms, which is:

21.9 volts RMS across 16 ohms

OUTPUT LOAD IMPEDANCE

8 ohms, or 16 ohms

RATED POWER BAND

20 Hz to 20,000 Hz

TOTAL HARMONIC DISTORTION

0.2% maximum harmonic distortion at any power level from 250 millivolts to rated power per channel from 20 Hz to 20,000 Hz, both channels operating

INTERMODULATION DISTORTION

0.2% if instantaneous peak power is twice rated continuous average power or less per channel with both channels operating for any combination of frequencies 20 Hz to 20,000 Hz

FREQUENCY RESPONSE

20 Hz to 20,000 Hz +0.5 -0.5 dB at rated power

NOISE AND HUM

Power Amplifier: 95 dB below rated output
Tape Input: 90 dB below rated output
Phono Input: 76 dB below 10 mV rated power

RATINGS**DAMPING FACTOR**

56 at 8 ohms output
112 at 16 ohms output

INPUT SENSITIVITY AND IMPEDANCE

Power Amplifier: 2.5 volts, 100,000 ohms
Phono 1 and Phono 2: 2.0 mV, 47,000 ohms
Tape 1 and Tape 2: 250 mV, 250,000 ohms

TAPE OUTPUT:

Tuner: 1.0 volt at 100% modulation (FM)
Tape 250 mV with rated input at 500 Hz
Phono: 1.2 volts with 1 mV at 1000 Hz

BASS CONTROLS

±16 dB at 20 Hz

TREBLE CONTROLS

±16 dB at 20,000 Hz

L. F. FILTER

Active filter, 12 dB per octave roll off below 50 Hz, down 18 dB at 20 Hz

H. F. FILTER

Active filter, 12 dB per octave roll off above 7,000 Hz, down 18 dB at 20,000 Hz

AM TUNER SECTION**SENSITIVITY**

75 uV IHF (external ant.)

SIGNAL TO NOISE RATIO

45 dB minimum IHF; 55 dB at 100% modulation

HARMONIC DISTORTION

Does not exceed 1% at 30% modulation

FREQUENCY RESPONSE

3500 Hz at -6 dB down

ADJACENT CHANNEL SELECTIVITY

30 dB minimum IHF

IMAGE REJECTION

65 dB minimum, 540 kHz-1600 kHz

FM TUNER SECTION**USEABLE SENSITIVITY**

2.5 microvolts at 100% modulation (±75 kHz deviation) for 3% total noise and harmonic distortion

SIGNAL TO NOISE RATIO

70 dB below 100% modulation

HARMONIC DISTORTION**MONO**

Will not exceed 0.3% at 100% modulation ±75 kHz deviation

STEREO

Will not exceed 0.7%

AUDIO FREQUENCY RESPONSE

±1 dB 20 Hz to 15,000 Hz with standard de-emphasis (75µsec.) and 19,000 Hz pilot filter

CAPTURE RATIO

1.8 dB

SELECTIVITY

55 dB alternate channel selectivity IHM minimum

SPURIOUS REJECTION

90 dB IHF minimum

IMAGE REJECTION

80 dB; 88 to 108 kHz (IHF)

STEREO SEPARATION

34 dB at 1,000 Hz

SCA FILTER

50 dB rejection from 67 kHz to 74 kHz. 275 dB per octave slope

TRANSISTOR COMPLEMENT

53 silicon field effect or bipolar transistors, 39 diodes, 3 integrated circuits, 4 thyristors

POWER REQUIREMENTS

120 volts, 50/60 Hz, 40 watts at zero signal output, 300 watts at rated output

MECHANICAL SPECIFICATIONS**SIZE**

Front panel measures 16 inches wide (40.64 cm) by 5½ inches high (13.97 cm). Chassis measures 15 inches wide (38.1 cm) by 5½ inches high (13.02 cm) by 15 inches deep (38.1 cm) including back panel connectors. Knob clearance required is 1½ inches (3.81 cm) in front of mounting panel

FINISH

Front panel is anodized gold and black

WEIGHT

33 pounds (14.97 kg) net, 46 pounds (20.87 kg) in shipping carton

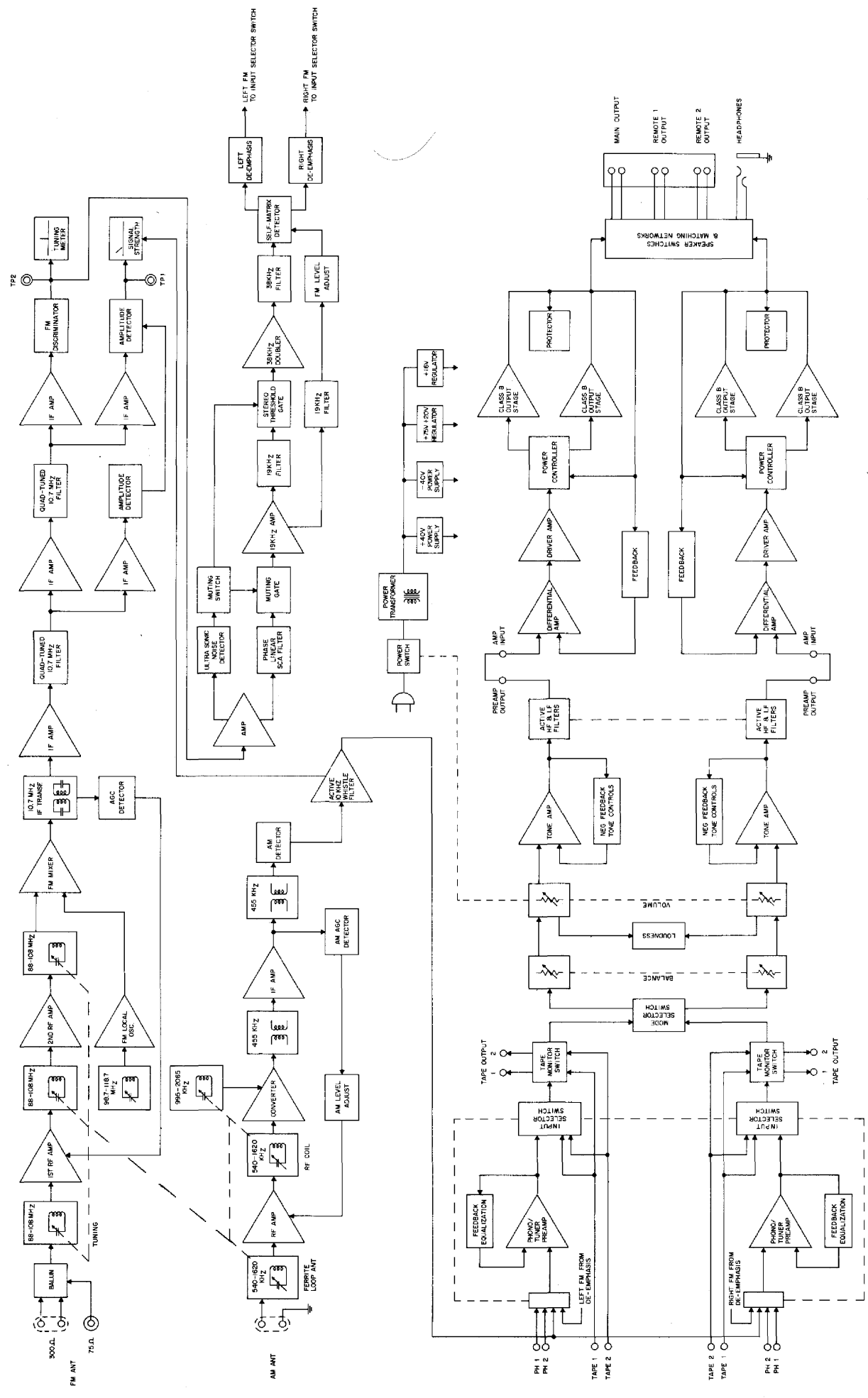

MAC 1900 BLOCK DIAGRAM

SCHEMATIC NOTES

1. Printed circuit board components are outlined on the schematics by dotted lines. The circled numbers on the dotted lines correspond to the numbers on the printed circuit board layouts.
2. The heavy lines on the schematics denote the primary signal path.
3. The terminal numbering of rotary switches is for reference only.
4. A dot on the rotor of a rotary switch indicates that there is an electrical connection between the front and rear rotor section.
5. Unless otherwise specified: Resistance values in the AM, FM & MPX, and Preamp sections are in ohms, 1/4 watt, and 10% tolerance; resistance values in the Power Output and Power Supply sections are in ohms, 1/2 watt, 10% tolerance; capacitance values smaller than 1 are in microfarads (μF); capacitance values greater than 1 are in picofarads (pF); inductors are in microhenries (μH).
6. All voltages indicated on the schematics are measured under the following conditions:

Use of an 11 megohm input impedance VTVM. All voltages $\pm 10\%$ with respect to ground.
 No signal at antenna or other input terminals. AC input at 120 volts, 50/60 Hz.

Front panel controls at:

Stereo switch	In	Muting	Out
Speaker switches	Out	Filters	Out
Volume control	Max	Loudness	Out
Balance control	Zero	Tape Monitors	Out
Tone controls	Flat	Tuning Indicator	100MHz (no signal)
Input selector	FM (to measure FM section) AM (to measure AM section)		

7. In units with Serial No.'s below 4X673: R224 is 7.5k; R321 and R322 is 1M; R323 and R324 is 560k; R399-7 and R399-8 are not used and C337 and C338 are 1.2pF.
8. In units with Serial No.'s below 5X424: R425 and R426 are 220 Ω ; R427 and R428 are 180 Ω ; R429, 430, 447 and 448 are 47 Ω and R304 and R305 are 47k.
9. In units with Serial No.'s below 6X182, C517 a dual .01 μF capacitor is not used. Two .005 μF capacitors may be used in place of the .01 μF dual in some units.
10. In units with Serial No.'s below 5X690: R135, R138, R139 and R142 are 39k.
11. In units with Serial No.'s below 5X970, R149 is not used.
12. In units with Serial No.'s below 5X369: C407 and C408 are 470pF; C413, C414, C415 and C416 are 1000pF and D413 and D414 are not used.
13. In units with Serial No.'s above AL1900 the power output PC boards may be 044-570 (128-169). If so refer to MAC 1900 Service Information Manual for units with Serial No.'s starting with AN1001 for schematic and PC board layout.

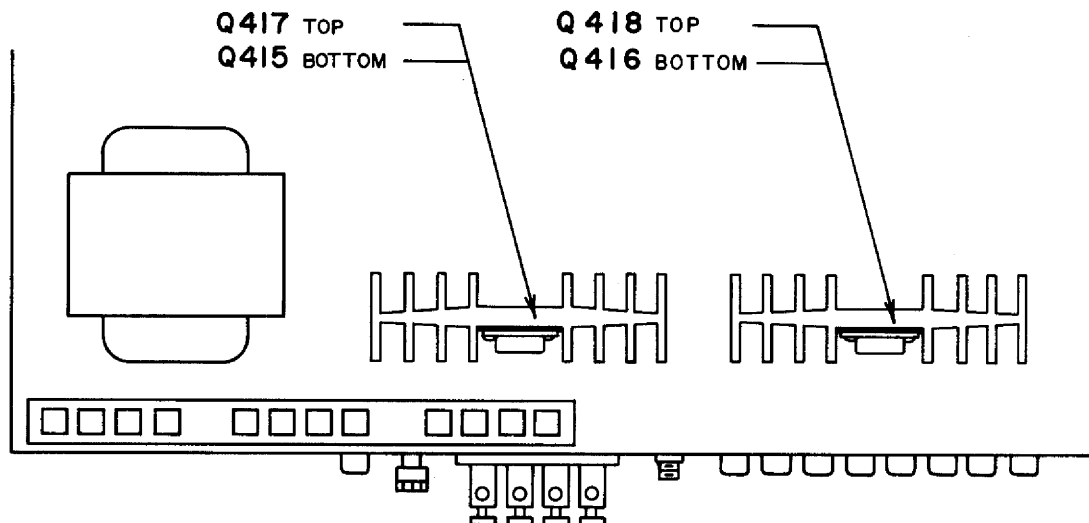

LOCATION OF TRANSISTORS NOT ON PC BOARD

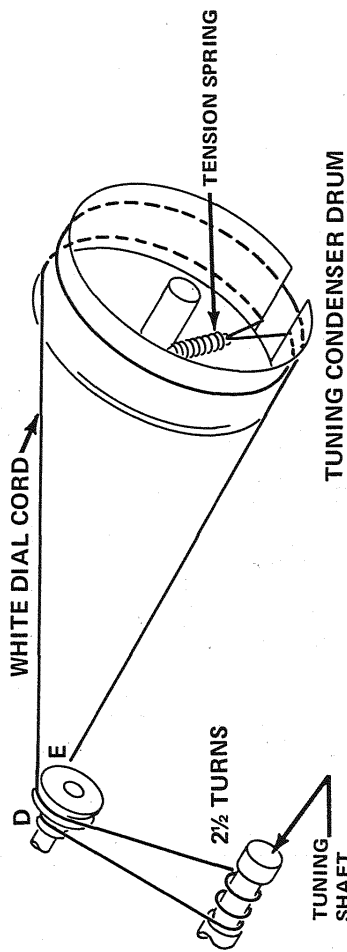

TUNING CONDENSER DRIVE

- Step 1 Before stringing unit, turn pointer adjustment screw until pulley E is in the center of its travel.
- Step 2 String unit as shown.
- Step 3 After stringing unit, turn tuning shaft until pointer is as far to the left as it will go. Turn the pointer adjustment screw until the pointer coincides with the zero bar of the logging scale.
- Step 4 Turn the tuning knob making the pointer move back and forth from one end of the dial scale to the other. Return pointer to the far left and, if necessary, re-adjust pointer position.

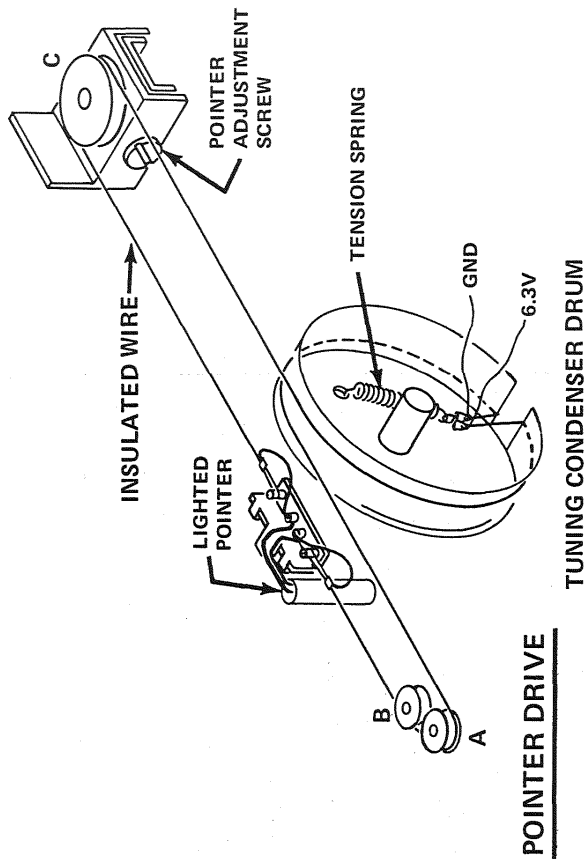

TUNING CONDENSER DRUM (TOP VIEW)

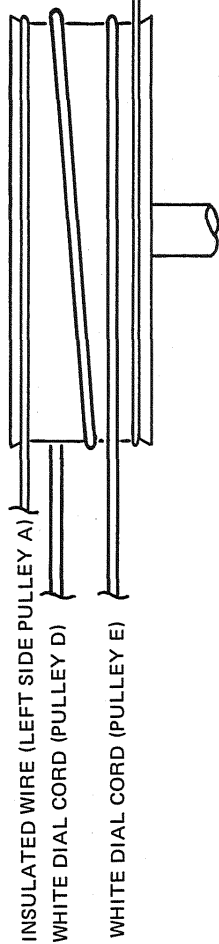

MIXER & L.O. PC BOARD 044-367

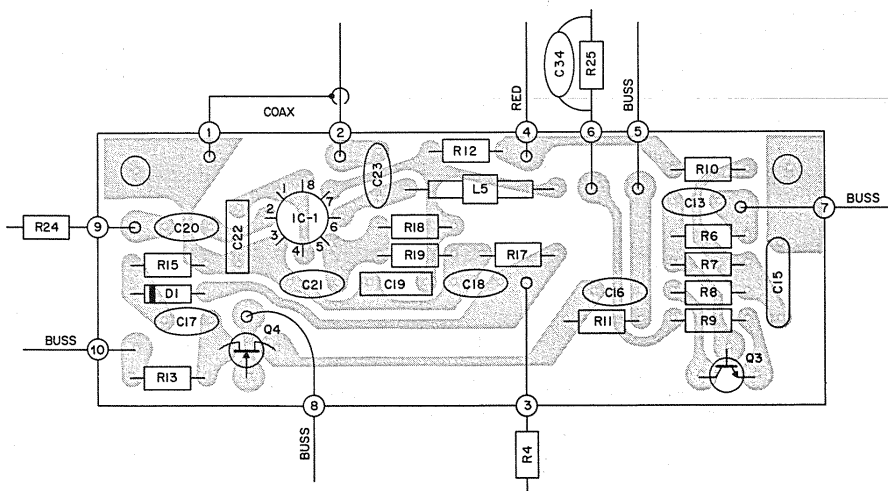

IF & MPX PC BOARD 044-343

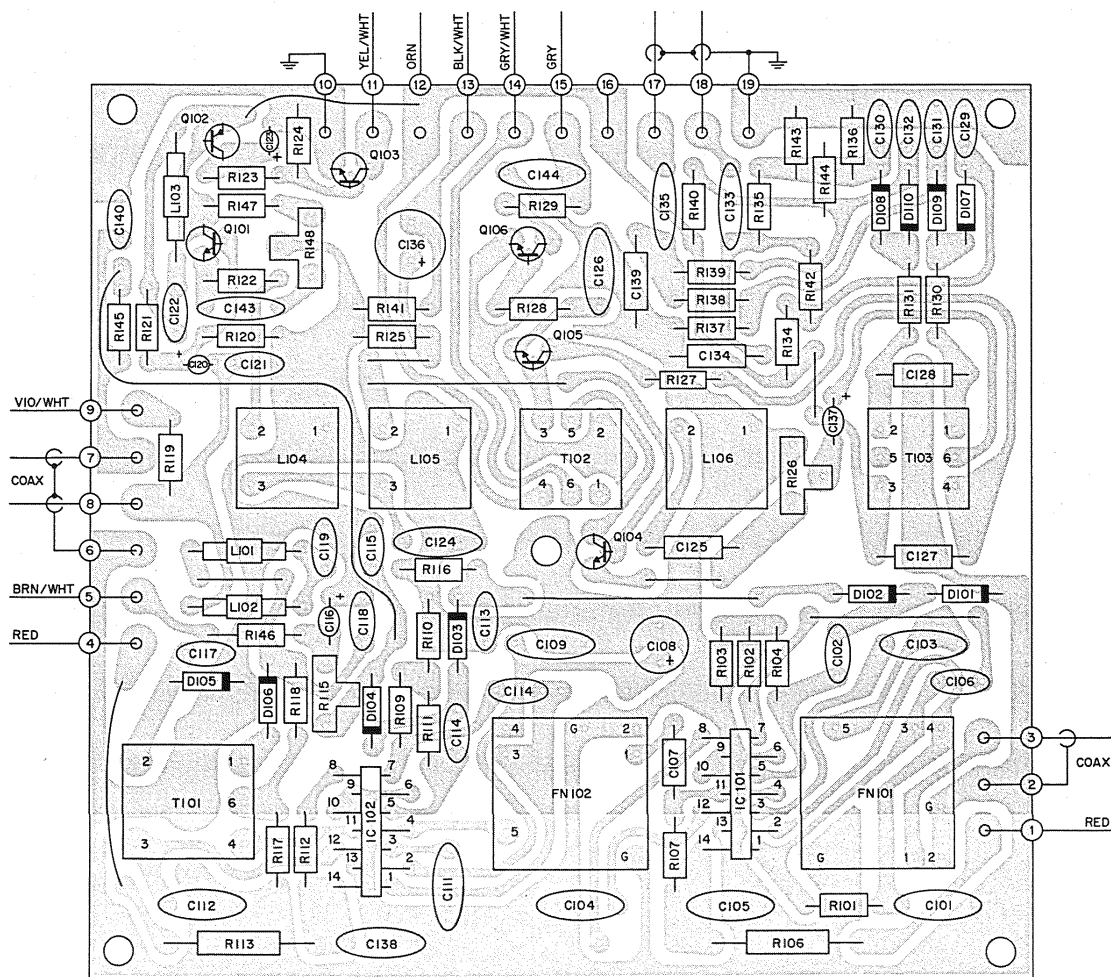

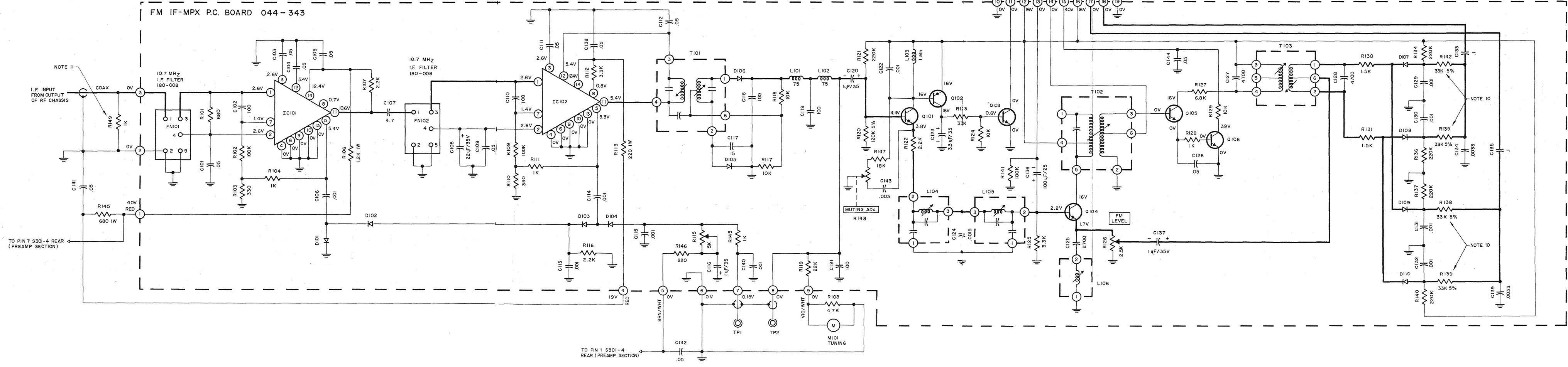
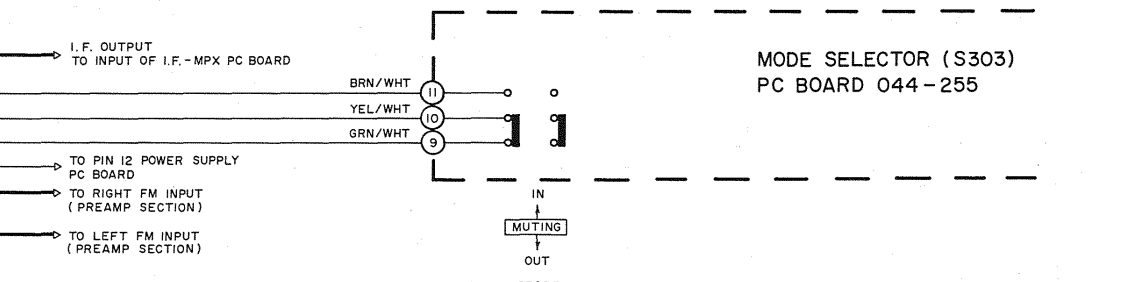
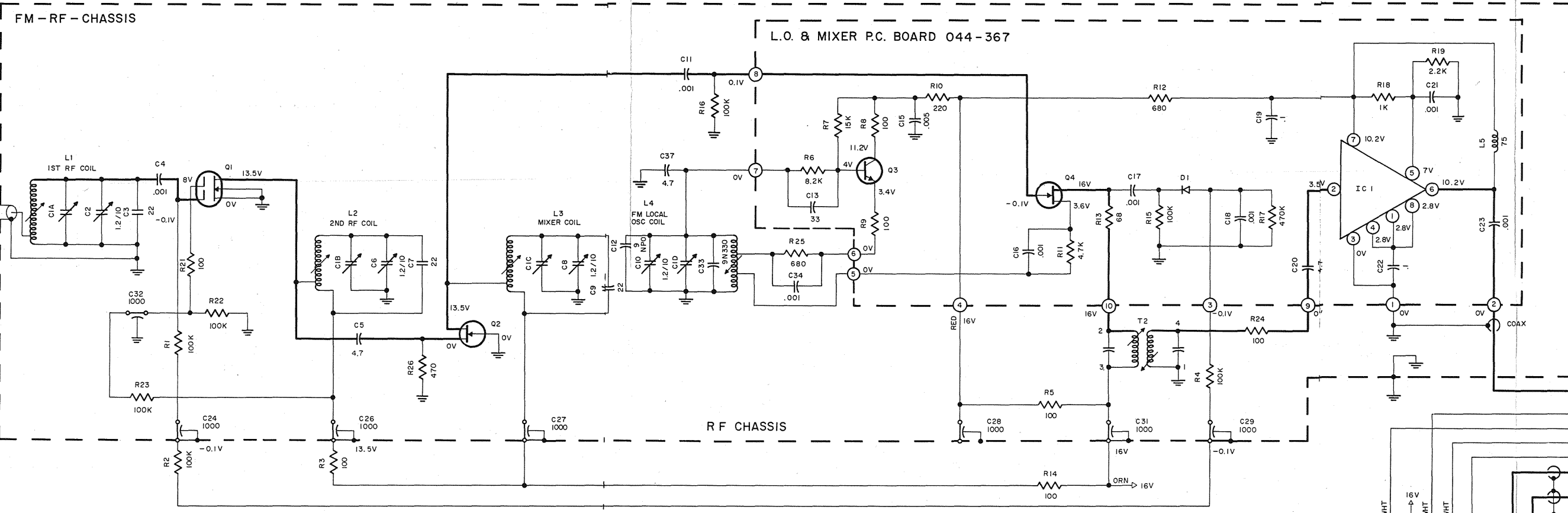

NOTE II

NOTE IO

NOTE IO

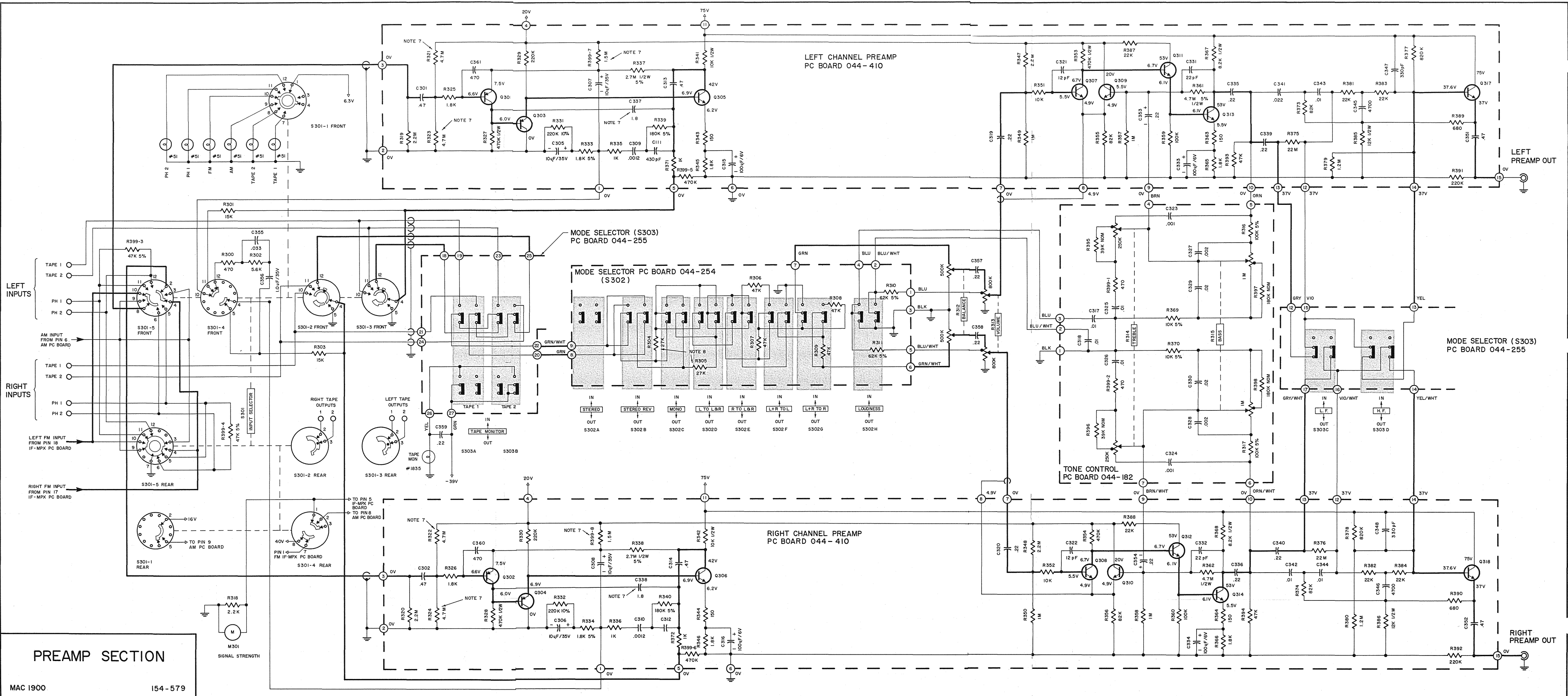

LEFT CHANNEL PREAMP
PC BOARD 044-410

LEFT PREAMP OUT

MODE SELECTOR (S303)
PC BOARD 044-255

MODE SELECTOR PC BOARD 044-254
(S302)

MODE SELECTOR (S303)
PC BOARD 044-255

TONE CONTROL
PC BOARD 044-182

RIGHT CHANNEL PREAMP
PC BOARD 044-410

RIGHT PREAMP OUT

PREAMP SECTION

LEFT CHANNEL PREAMP PC BOARD 044-410

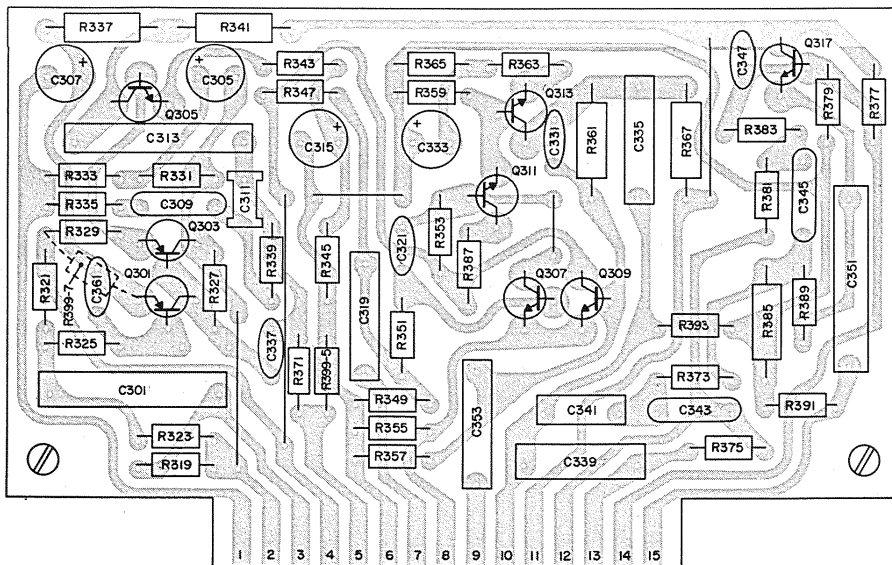

RIGHT CHANNEL PREAMP PC BOARD 044-410

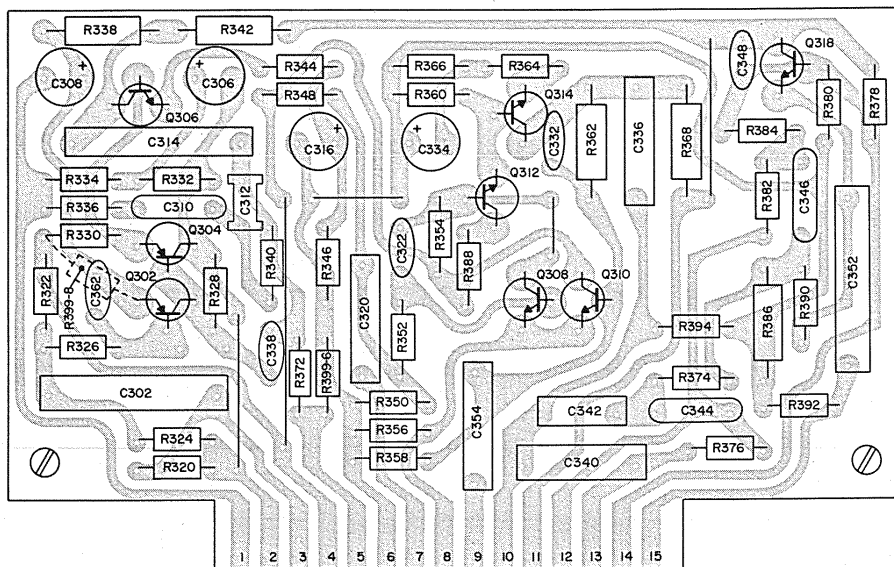

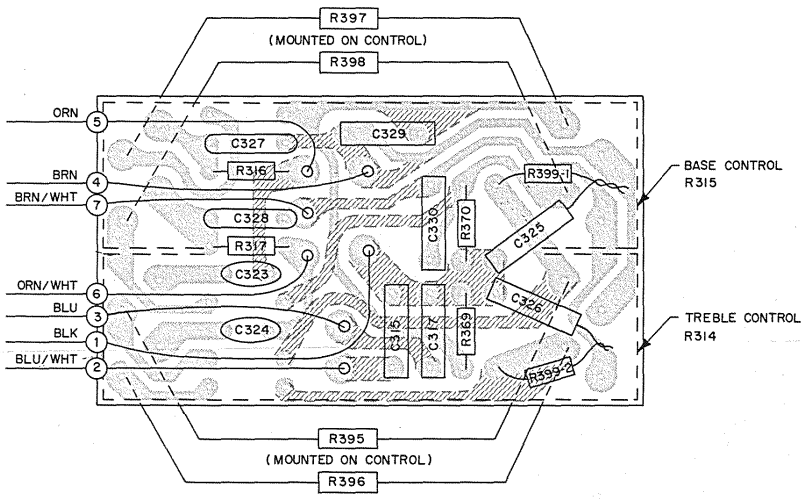

TONE CONTROL PC BOARD 044-182

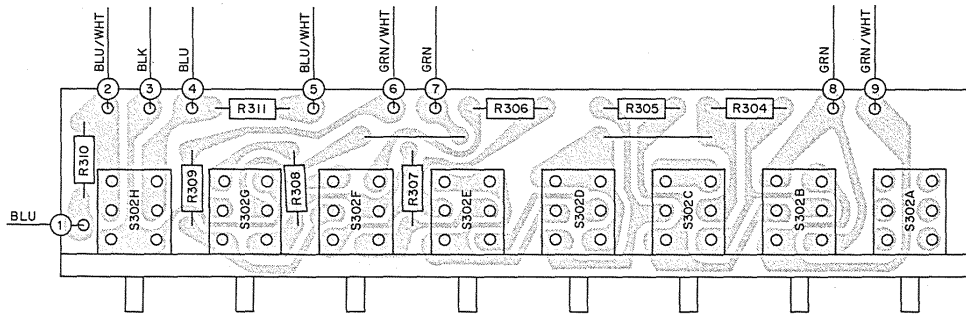

MODE SELECTOR (S302) PC BOARD 044-254

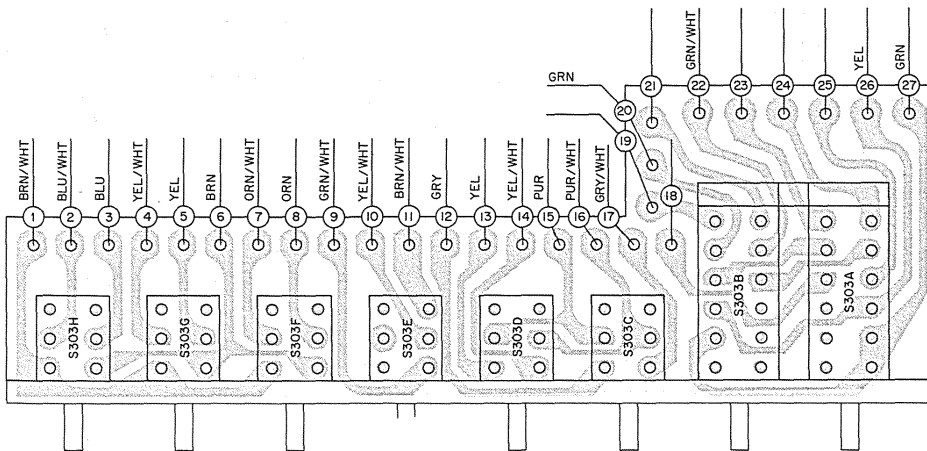

MODE SELECTOR (S303) PC BOARD 044-255

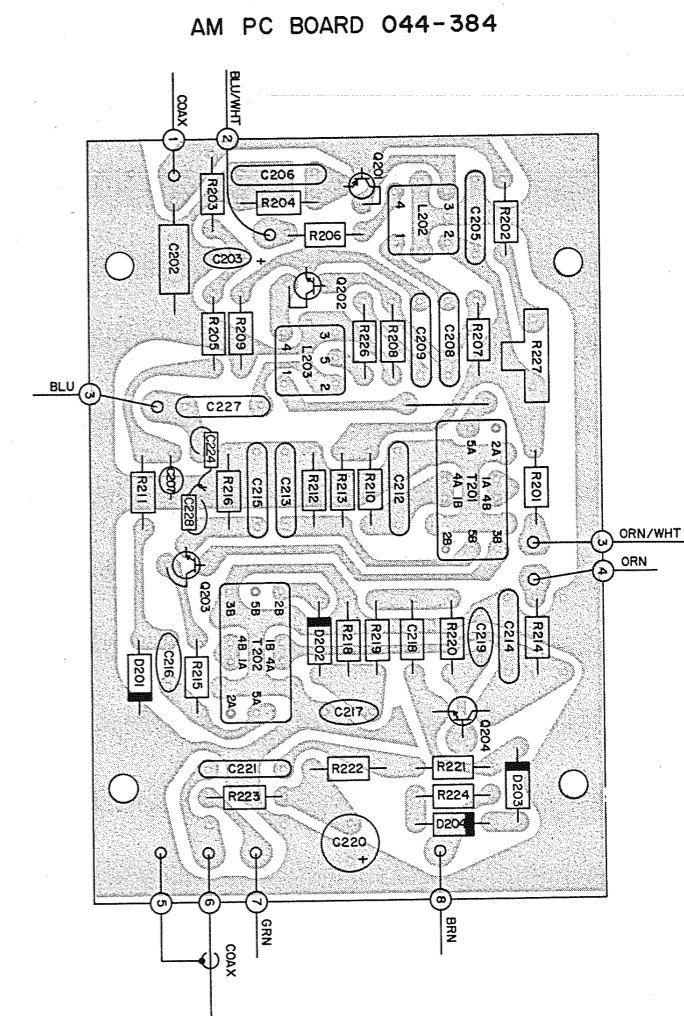
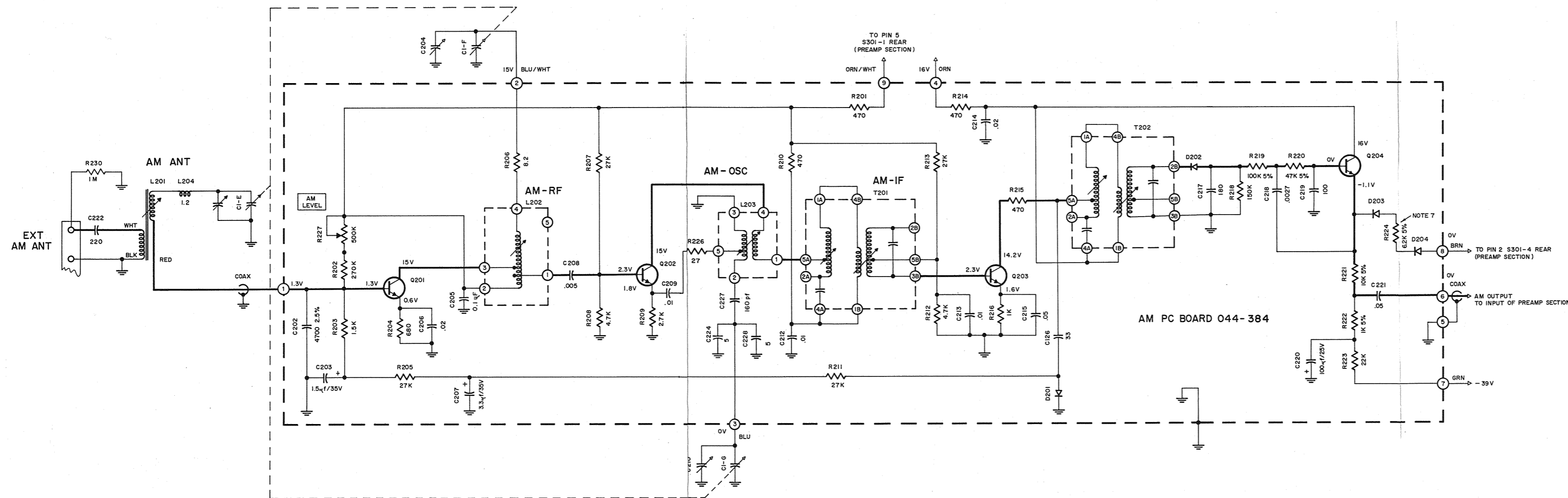

AM SECTION

MAC 1900 154-580

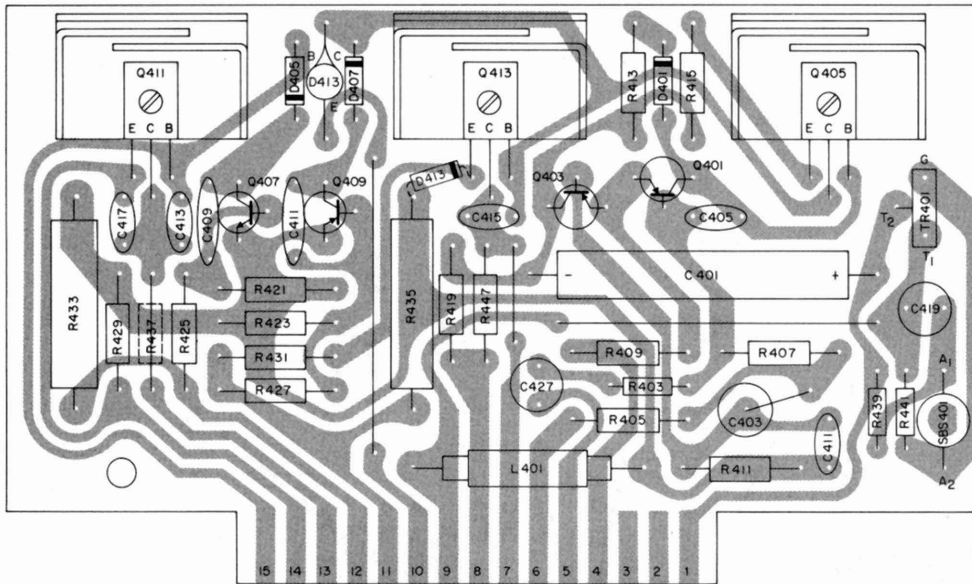

LEFT CHANNEL
POWER OUTPUT
PC BOARD 044-411
NOTE 13

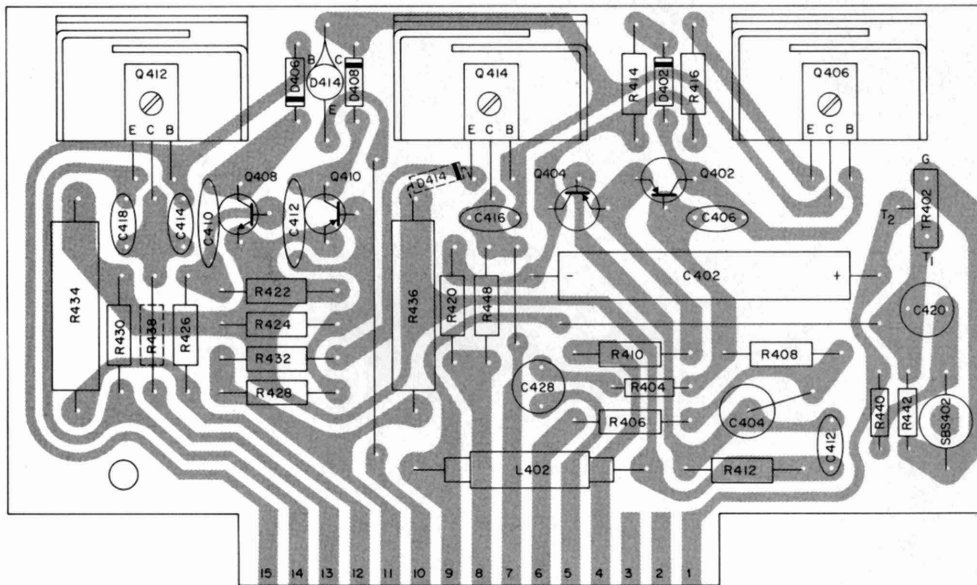

RIGHT CHANNEL
POWER OUTPUT
PC BOARD 044-411
NOTE 13

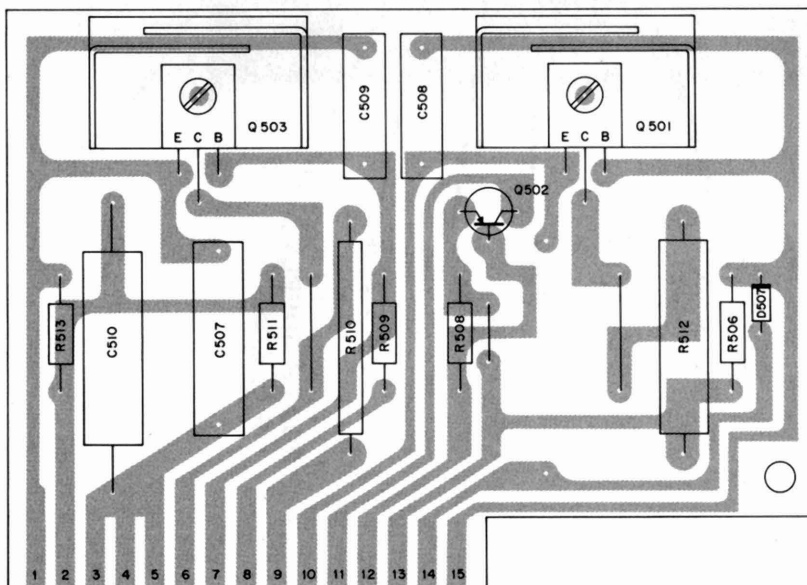

POWER SUPPLY
PC BOARD
044-180

POWER SUPPLY PC BOARD O44-180

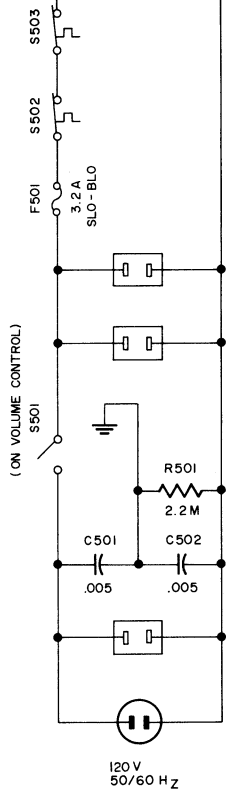
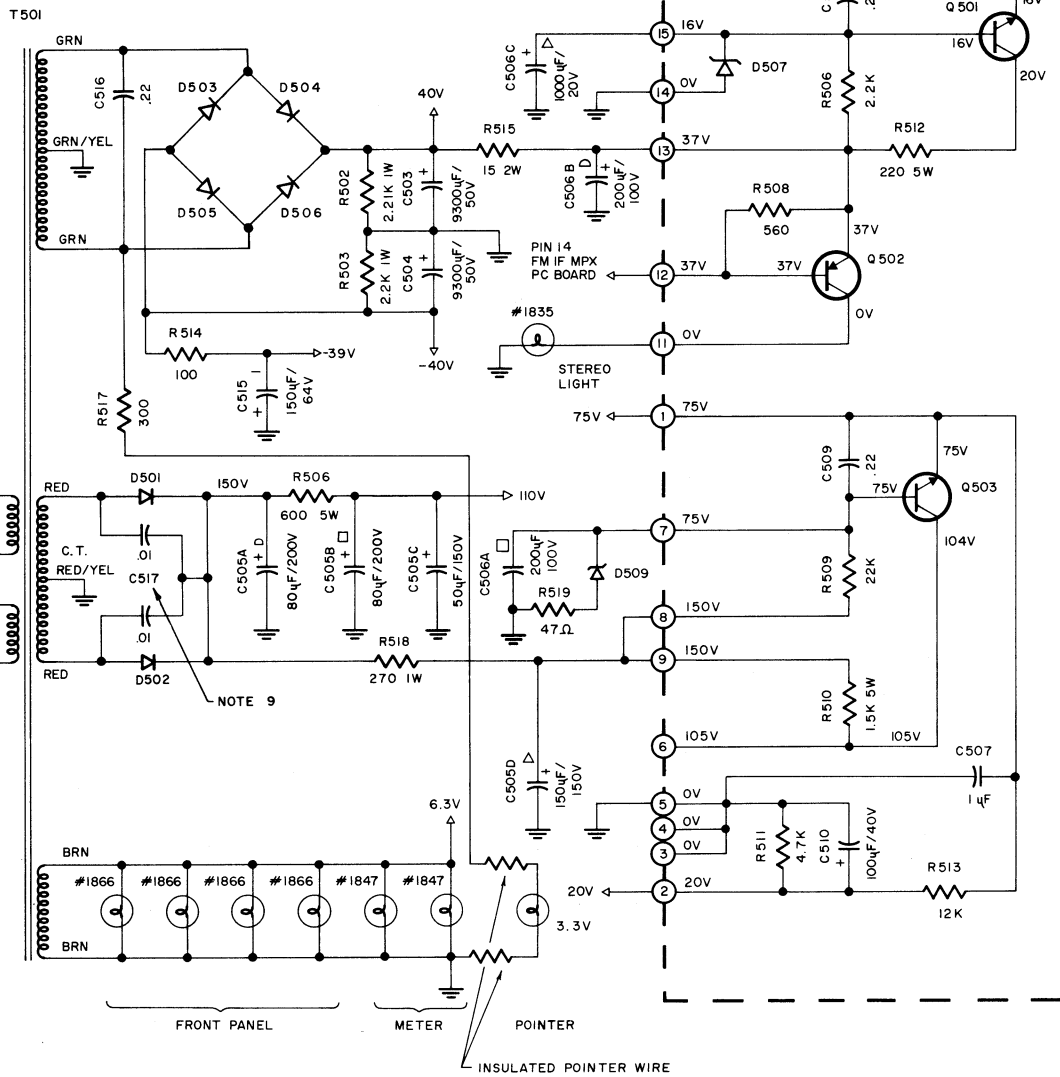

POWER SUPPLY SECTION

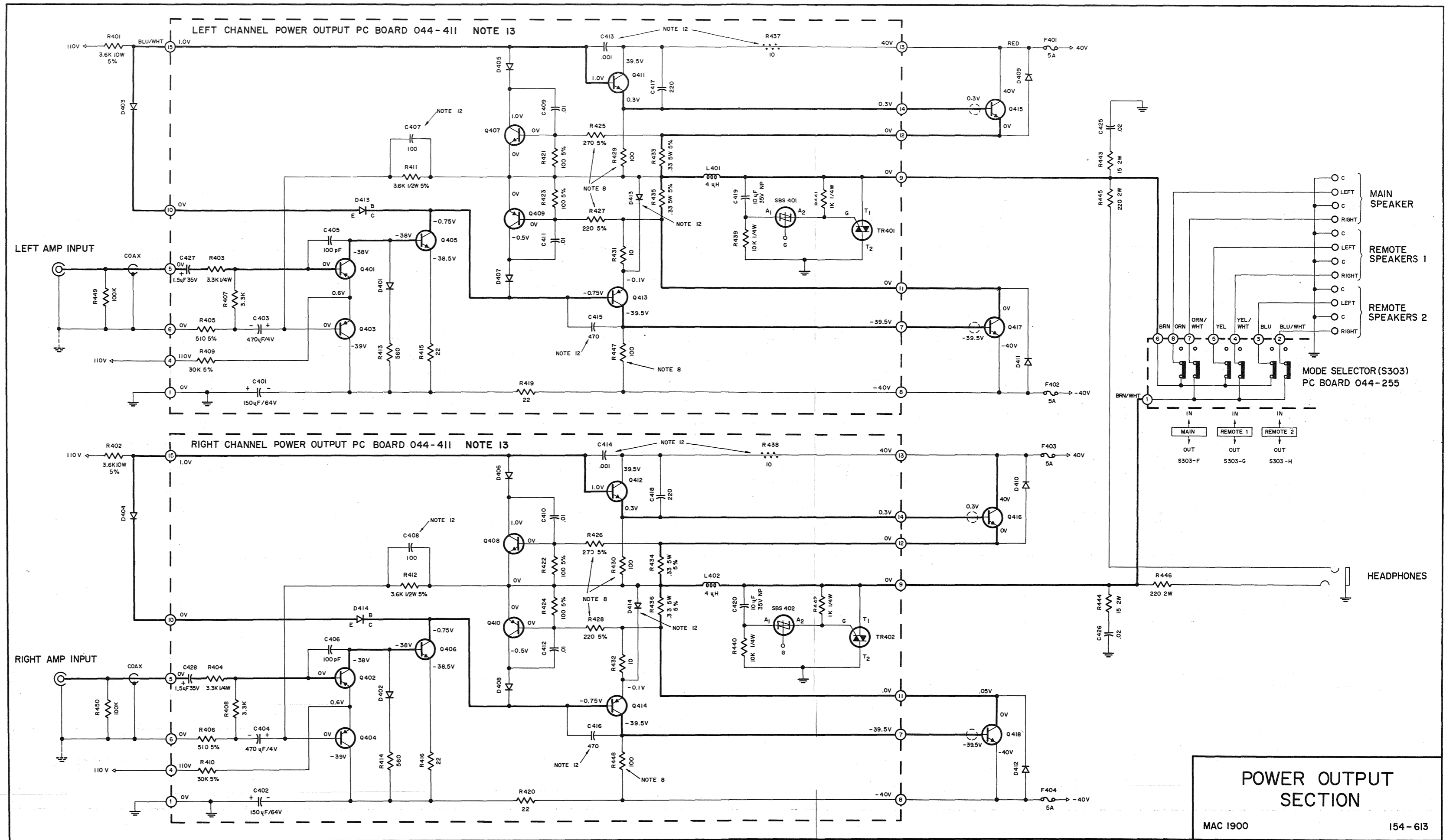

POWER OUTPUT SECTION
 MAC 1900 154-613

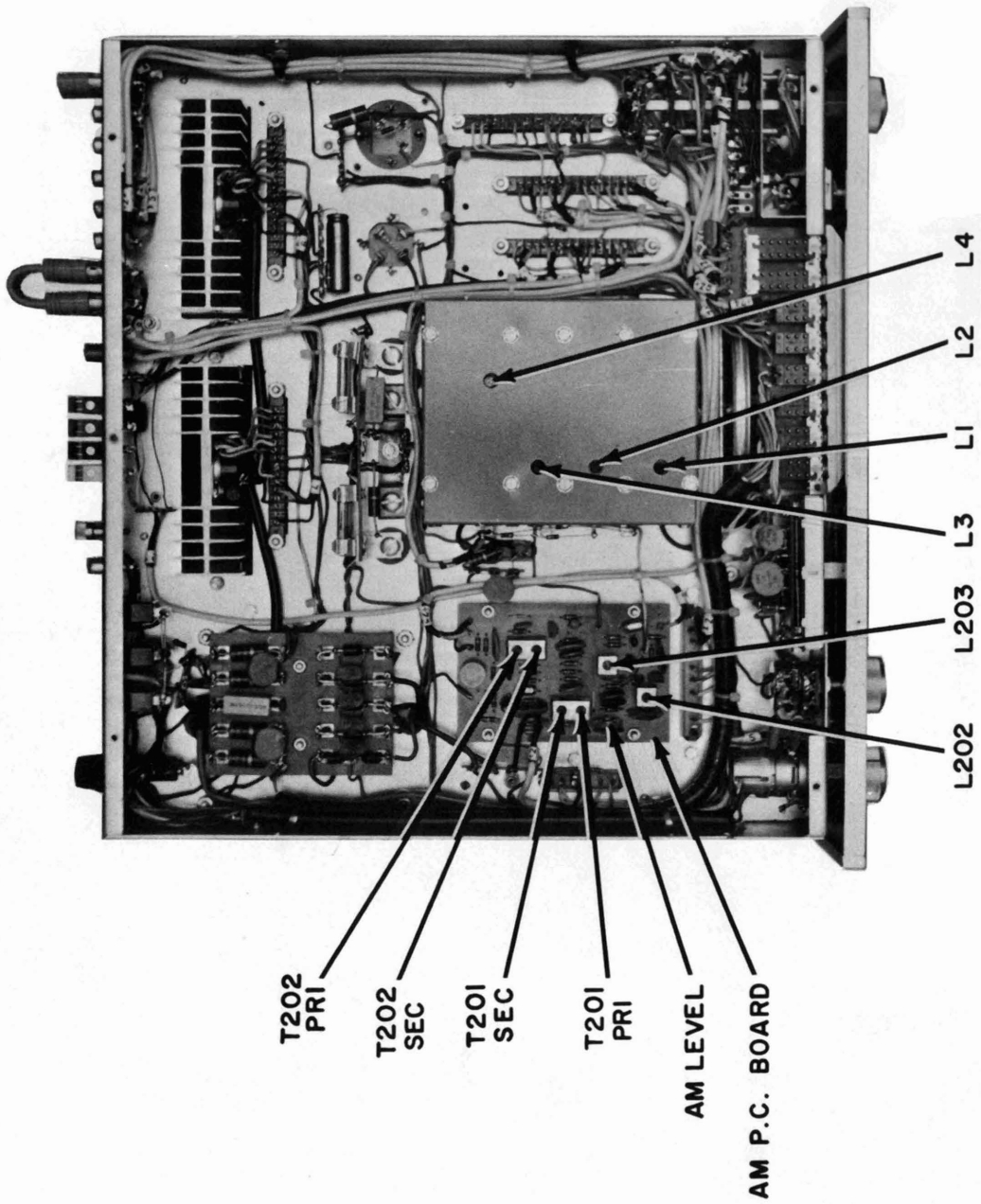

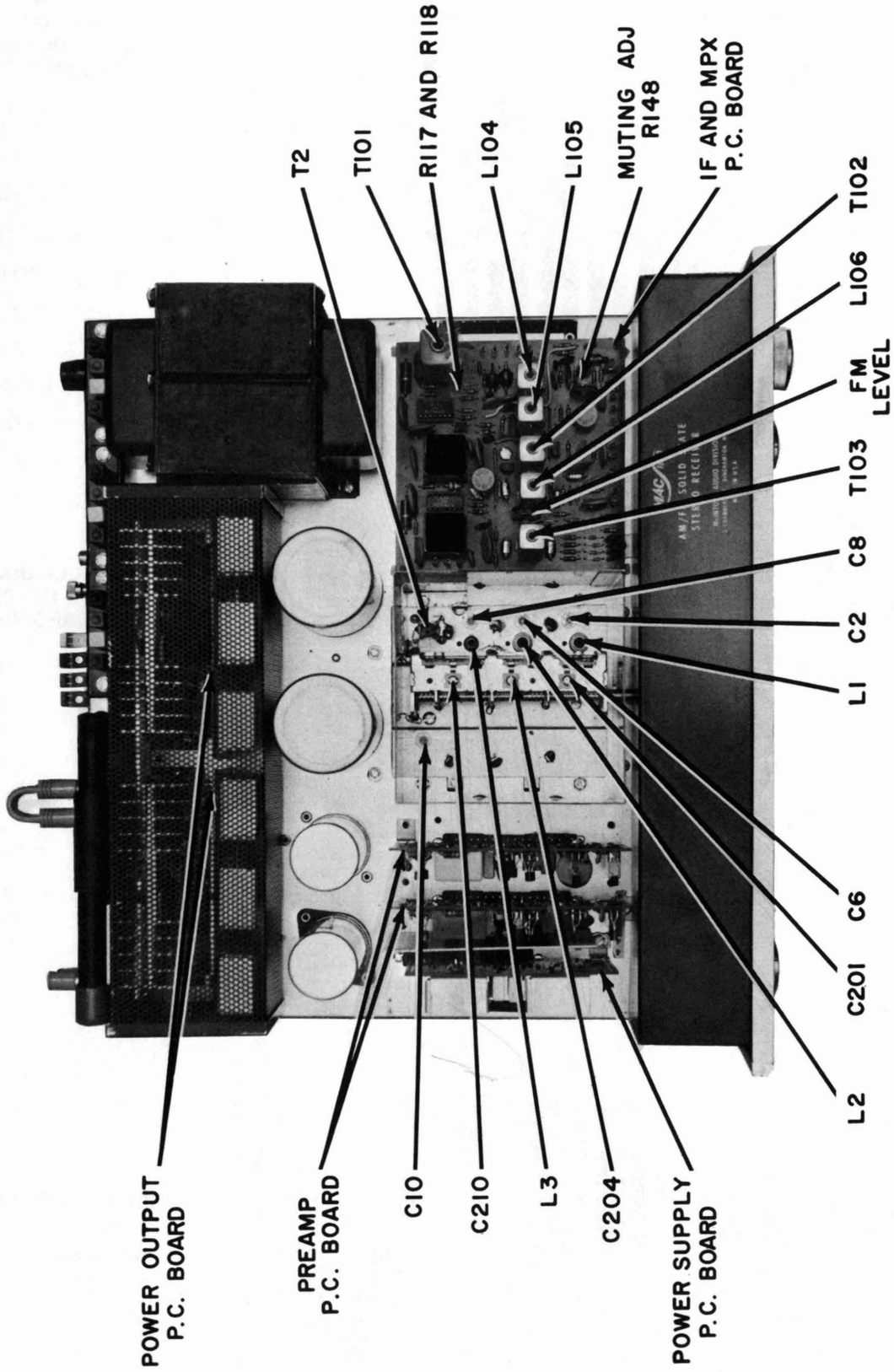

MAC 1900 ALIGNMENT INSTRUCTIONS

All McIntosh receivers are carefully aligned and tested at the factory using the finest available test equipment. All McIntosh receivers will meet their published specifications when shipped from the factory.

After extensive operation, or servicing, it may be desirable to realign the receiver circuits for best performance. The charts below give complete information on the circuit realignment procedure for the MAC 1900.

The test equipment listed (or its equivalent) is necessary to properly align an MAC 1900. The accuracy of the alignment will be directly related to the accuracy and calibration of the test equipment used.

If the necessary test equipment is not available, alignment should not be attempted. For additional information, contact Customer Service Department, McIntosh Laboratory, Inc., 2 Chambers Street, Binghamton, New York 13903 (telephone 607-723-3512).

Alignment should be done in the following order: AM-FM-MPX.

TEST EQUIPMENT REQUIRED

1. FM Signal Generator (Measurement 188 or Sound Technology 1000A).
2. VTVM (RCA WV96C).
3. Multiplex Generator (Radiometer SMG1) or Sound Technology 1000A.
4. 10.7MHz Generator (preferably crystal controlled).
5. Oscilloscope (Hewlett-Packard 120B or equivalent).
6. Harmonic Distortion Analyzer (Hewlett-Packard 333A or equivalent).

AM ALIGNMENT

STEP	TUNER DIAL SETTING	SIGNAL GENERATOR			INDICATOR		ADJUST	TEST LIMITS	REMARKS
		FREQ.	COUPLING	MODULATION	TYPE	CONNECTED TO			
1	Point of no interference or signal.	455kHz	Through external .01µF capacitor to pin 2 on AM circuit board	CW	Signal strength meter.	Normal.	Pri. & Sec. cores of T201 & T202.	As the tuner output increases, attenuate generator output to keep meter indication below 4.	
2	600kHz	600kHz	Through a 200pF capacitor to ant. terminals.	Same	Same	Same	L203 (oscillator coil.)	Same as Step 1.	
3	1400kHz	1400kHz	Same	Same	Same	Same	C210 (oscillator trimmer)	Repeat Steps 2 & 3 until dial calibration is accurate.	
4	600kHz	600kHz	Same	Same	Same	Same	L201 (AM antenna rod) & L202 (AM-RF)	Same as Step 1 except adjust generator so that output signal is just above the noise level. Position antenna rod away from chassis and nearby objects.	
5	1400kHz	1400kHz	Same	Same	Same	Same	C201 (AM antenna trimmer) & C204 (AM-RF trimmer).	Repeat Steps 4 & 5 until output is as high as possible.	
6	1000kHz	1000kHz	Same	30% @ 400Hz	Distortion Analyzer.	L or R output.		With a distortion analyzer, the following measurements can be performed: 1. With a 10mV input signal adjust "AM Level" control for 0.3 volts of audio output at tape-outputs. This will correspond to 1.0 volt audio output for a 100% modulated signal. 2. With a 1mV input signal, harmonic distortion, whistle filter attenuation at 10kHz modulating frequency and signal to noise ratio may be measured. 3. IHFM sensitivity of 75 microvolts for 20dB signal to noise ratio. (This measurement is only possible in the absence of man-made interference, as fluorescent lamps, etc.)	

FM ALIGNMENT

STEP	TUNER DIAL SETTING	SIGNAL GENERATOR			INDICATOR		ADJUST	TEST LIMITS	REMARKS
		FREQ.	COUPLING	MODULATION	TYPE	CONNECTED TO			
1	Point of no interference or signal	10.7MHz	Through external .01µF capacitor to pin #3 of FM-IF-MPX PC Board.	CW	VTVM	TP #2.	Top (Sec.) Core of T101.	Turn muting off for alignment tests.	
2	Same	Same	Same	Same	Same	Junction of R117-118.	Bottom (Pri.) core of T101.	If a distortion analyzer is available, omit this step. Adjust T102 Primary after Step 5. At that time, use a 1mV signal from an FM generator, modulate 100% @ 400Hz. Adjust primary of T102 for minimum distortion. Should be less than 0.5%.	
3	105MHz	300Ω antenna terminals w/ matching network.	100% @ 400Hz.	VTVM connected to TP#1 and oscilloscope connected to L or R tape output.	Same	TP #1.	Oscillator trimmer C10.	As TP#1 voltage increases, reduce output of signal generator to keep TP#1 voltage at a low level (less than -.75 volt).	
4	90MHz	Same	Same	Same	Same	TP #1.	Oscillator Coil L4.	Repeat Steps 3 and 4 until dial calibration is accurate.	
5	Same	Same	FM ±300kHz sweep at 60Hz rate.	Oscilloscope.	Same	TP #1.	Top (Pri.) and Bottom (Sec.) cores of T2.	Connect scope for overall response display. Hold the signal generator output to a low level such that the DC voltage at TP #1 is less than -.0.5 volt.	
6	105MHz	Same	100% @ 400Hz.	VTVM connected to TP #1 and scope connected to L or R tape output.	Same	TP #1.	Mixer, RF-2, and RF-1 trimmers C8-6-2.	Same as Step 3.	
7	90MHz	Same	Same	Same	Same	TP #1.	Mixer, RF-2, and RF-1; coils L3, 2, 1.	Same as Step 3. Then repeat Steps 6 and 7 until TP#1 voltage is as high as possible for the least signal input at both alignment frequencies.	
8	Same	Same	Same	VTVM connected to TP#1 and a harmonic distortion analyzer to L or R output.	Same	TP #1.		This step is an overall sensitivity check. Reduce input signal to the point where total noise and distortion reads 3% (-30dB). The input signal will then be the usable sensitivity and should be less than 2.5µV.	

MULTIPLY DECODER ALIGNMENT

STEP	TUNER DIAL SETTING	SIGNAL GENERATOR			INDICATOR		ADJUST	TEST LIMITS	REMARKS
		FREQ.	COUPLING	MODULATION	TYPE	CONNECTED TO			
1	100MHz	300Ω antenna terminals w/ approx 1000 microvolts signal w/ matching network.	75kHz deviation @ 67kHz.	AC-VTVM or oscilloscope w/very low cap. probe.	Pin 13 on MPX/IF PC Board.	L104 and L105 (SCA adj.)	Minimum output @ L or R output jack.	Adjust for minimum 67kHz output.	
2	Same	Same	19kHz stereo pilot.	Same	Pin 14 on MPX/IF PC Board	L106 (19kHz phase adj.) & T102 (19kHz trimmer.)	Adjust for maximum AC voltage.	Decrease pilot level, if necessary, so that 19kHz circuits do not limit or saturate.	
3	Same	Same	Same	Same	T103, Pin 1 or 2.	T103 Top (Pri.) & bottom (Sec.) tuning cores	Adj. for maximum AC voltage.	Decrease pilot level so that 19kHz and 38kHz circuits do not limit. Mode switch must be in stereo position.	
4	Same	Same	1kHz (100% modulation) L or R only, pilot level, normal end on.	AC-VTVM	L or R output jack.	T103, Bottom (Sec.) tuning cores.	35dB separation or more.	Modulate left channel and measure right channel output. Adjust bottom tuning core (Sec.) for minimum right channel output (maximum separation). Then, reverse channels and measure left channel separation. For this adjustment and measurement, no test lead should be connected to TP #2.	
5	Same	Same	Same	Same	Same		Less than 15mV of residual.	Adjust "FM Level" control (R126) for 1 volt of audio output at tape output jacks. Then, turn off the modulation and measure the residual of the 19kHz and 38kHz frequencies.	

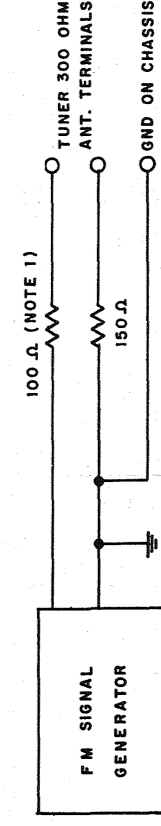

Note 1: If signal generator has other than 50 ohm internal impedance, use a resistor of 150 ohms less internal generator impedance.

REPLACEMENT PARTS

All parts not listed are common items obtainable from radio parts jobbers.

Replacement parts may be obtained when ordered by PART NUMBER from:

McIntosh Laboratory, Inc.
Customer Service Department
2 Chambers Street
Binghamton, New York 13903
(telephone 607-723-3512)

CAPACITORS

Symbol Number	Description	Part Number
C19	Mylar 0.1 μ F 100V	064-098
C22	Mylar 0.1 μ F 100V	064-098
C108	Elect. 10 μ F 50V	066-221
C116	Ta. Elect. 1 μ F 35V	066-147
C120	Ta. Elect. 1 μ F 35V	066-147
C123	Ta. Elect. 3.3 μ F 35V	066-170
C125	Polystyrene 2700pF 63V	064-093
C127,128	Polystyrene 4700pF 63V	064-091
C134	Polystyrene 3300pF	064-090
C136	Elect. 100 μ F 25V	066-161
C137	Ta. Elect. 1 μ F 35V	066-147
C139	Polystyrene 3300pF	064-090
C202	Polystyrene 4700pF 63V	064-091
C203	Ta. Elect. 1.5 μ F 35V	066-158
C207	Ta. Elect. 3.3 μ F 35V	066-170
C218	Polystyrene 2700pF 63V	064-093
C220	Elect. 100 μ F 25V	066-161
C301,302	Mylar 0.47 μ F 250V	064-069
C305,306	Ta. Elect. 10 μ F 50V	066-221
C307,308	Ta. Elect. 10 μ F 63V	066-178
C313,314	Mylar 0.47 μ F 250V	064-069
C315,316	Ta. Elect. 100 μ F 16V	066-177
C317,318	Polyester 0.01 μ F 250V	064-101
C319,320	Mylar 0.47 μ F 250V	064-069
C325,326	Polyester 0.01 μ F 250V	064-101
C329,330	Polyester 0.022 μ F 250V	064-102
C333,334	Ta. Elect. 100 μ F 16V	066-226
C335,336	Mylar 0.22 μ F	064-068
C337,338	Mylar 0.047 μ F	064-066
C339,340	Mylar 0.22 μ F	064-068
C341,342	Mylar 0.01 μ F 250V	064-040
C343,344	Mylar 0.01 μ F 250V	064-040
C351,352	Mylar 0.47 μ F 250V	064-069
C353,354	Ta. Elect. 0.47 μ F 50V	066-174

C356	Ta. Elect. 1 μ F 35V	066-147
C357,358	Mylar 0.22 μ F 250V	064-043
C359,360	Mylar 0.22 μ F 250V	064-043
C401,402	Elect. 150 μ F 63V	066-205
C403,404	Elect. 470 μ F 4V	066-136
C419,420	Elect. 10 μ F 35V	066-173
C427,428	Ta. Elect. 1.5 μ F 35V	066-158
C503,504	Elect. 9300 μ F 50V	066-162
C505	Elect. 80/80/50/150 μ F 200/200/150/150V	066-095
C506	Elect. 200/200/1000 μ F 100/100/20V	066-172
C507	Mylar 1 μ F 250V	064-088
C508,509	Mylar 0.22 μ F	064-096
C510	Elect. 100 μ F 40V	066-206
C515	Elect. 150 μ F 63V	066-205

DIODES

D1	Ge. signal diode	070-003
D101,102	Ge. signal diode	070-003
D103,104	Ge. signal diode	070-003
D105,106	Si. signal diode	070-047
D107,108	Si. signal diode	070-047
D109,110	Si. signal diode	070-047
D201	Si. signal diode	070-047
D202	Ge. signal diode	070-003
D203	Si. signal diode	070-046
D401,402	Si. signal diode	070-047
D403,404	Si. diode	070-046
D405,406	Si. signal diode	070-047
D407,408	Si. signal diode	070-047
D409,410	Si. diode	070-031
D411,412	Si. diode	070-031
D413,414	Ge. PNP transistor	132-098
D501,502	Si. diode	070-031
D503,504	Si. diode	070-041
D505,506	Si. diode	070-041
D507	Zener diode 16V	070-048
D509	Zener diode 75V	070-025

CHOKE & COILS

L1	1st RF coil	122-109
L2	2nd RF coil	122-108
L3	Mixer coil	122-107
L4	Oscillator coil	122-106
L5	Choke 75 μ H	122-013
L8	Choke 0.47 μ H	122-010

L101,102	Choke	75 μ H	122-013
L103	Choke	1MH	122-092
L104,105	Filter coil (SCA)		122-093
L106	Filter coil (19kHz)		122-094
L201	AM antenna		122-110
L202	AM RF coil		122-086
L203	AM oscillator coil		122-085
L204	Choke	1.2 μ H	122-011
L401,402	Choke	4 μ H	122-105

TRANSISTORS

Q1	Si. M.O.S. F.E.T.		132-088
Q2	Si. Junction F.E.T.		132-049
Q3	Si. NPN transistor		132-087
Q4	Si. Junction F.E.T.		132-049
Q101	Si. NPN transistor		132-077
Q102	Si. PNP transistor		132-074
Q103,104	Si. NPN transistor		132-077
Q105	Si. NPN transistor		132-077
Q106	Si. NPN transistor		132-075
Q201,202	Si. NPN transistor		132-082
Q203	Si. NPN transistor		132-082
Q204	Si. NPN transistor		132-090
Q301,302	Si. PNP transistor		132-096
Q303,304	Si. PNP transistor		132-096
Q305,306	Si. NPN transistor		132-095
Q307,308	Si. NPN transistor		132-093
Q309,310	Si. NPN transistor		132-093
Q311,312	Si. NPN transistor		132-093
Q313,314	Si. NPN transistor		132-095
Q315,316	Si. NPN transistor		132-095
Q317,318	Si. NPN transistor		132-095
Q401,402	Si. PNP transistor		132-096
Q403,404	Si. PNP transistor		132-096
Q405,406	Si. NPN transistor		132-081
Q407,408	Si. NPN transistor		132-021
Q409,410	Si. PNP transistor		132-032
Q411,412	Si. NPN transistor		132-080
Q413,414	Si. PNP transistor		132-079
Q415,416	Si. NPN transistor		132-070
Q417,418	Si. NPN transistor		132-070
Q501	Si. NPN transistor		132-078
Q502	Si. PNP transistor		132-032
Q503	Si. NPN transistor		132-078

FUSES

F401,402	Fuse	5A	089-014
F403,404	Fuse	5A	089-014
F501	Fuse	3.2A slo-blo	089-006

POTENTIOMETERS

R312	Balance control		134-230
R313	Volume control		134-229
R314	Treble control		044-270
R315	Bass control		044-269

RESISTORS

R401,402	Wirewound	3.6k	10W	139-047
R433,434	Wirewound	0.33 Ω	5W	139-080
R435,436	Wirewound	0.33 Ω	5W	139-080
R504	Wirewound	600 Ω	5W	139-043
R510	Wirewound	1.5k	5W	139-079
R512	Wirewound	220 Ω	5W	139-009
R517	Wirewound	300 Ω	5W	139-098

SWITCHES

S301	Input selector switch		146-149
S302	Mode selector switch		150-008
S303	Mode selector switch		150-007
S502,503	Thermo cut-out switch		153-007

TRANSFORMERS

T1	Balun		043-226
T2	FM IF input		162-057
T101	Discriminator		162-036
T102	RF (19kHz)		162-055
T103	RF (38kHz)		162-054
T201,202	AM IF transformer		162-050
T501	Power transformer		159-093

THYRISTORS & TRIGGERS

TR401,402	Triac		131-005
SBS401,402	Bilateral switch		131-004

METERS

M301	Signal strength meter		124-017
M101	Tuning meter		124-016

MAC 1900

INTEGRATED CIRCUITS

ICI	Integrated circuit	133-005
IC101,102	Integrated circuit	133-002

FILTERS

FN101,102	IF filter (10.7MHz)	180-008
-----------	---------------------	---------

LAMPS

#51 (Inputs)	058-021
#1835 (Tape mon) (Stereo)	058-037
#1866 (Front panel)	058-014
#1847 (Meter)	058-008

FRONT PANEL & TRIM

Front panel	044-197
Dial glass	044-284
Tuning knob	044-523
Volume knob	044-524
Balance knob	044-524
Input selector knob	044-524
Bass knob	017-153
Treble knob	017-153
Pushbutton	090-105
Pushbutton w/blue dot	090-107
Pushbutton w/orn dot	090-108
Pushbutton w/grn dot	090-109
Pushbutton w/yel dot	090-110
Pushbutton w/red dot	090-111
Pushbutton w/wht dot	090-112

MISCELLANEOUS ITEMS

Plastic feet	017-041
Tuning shaft	021-075
Shipping carton	044-526
Push terminal (antenna)	074-032
Push terminal (speaker connections)	074-030
Owners manual	038-801
Mounting template #200	038-180
Shelf template #250	038-504
Dial cord	044-286
Dial pointer	044-285
Shorting plug	127-021
AC line cord	170-021

FM dipole antenna	170-033
Fuse holder	178-001
Hardware package	044-257
Jumper	015-005
Pointer	044-311

10C0527S7-M5891