



# *the* capacitor

**CDE**

**CORNELL-DUBILIER ELECTRIC CORPORATION**

Affiliated with Federal Pacific Electric Company

SOUTH PLAINFIELD

NEW JERSEY

VOLUME 25 — NO. 1

JANUARY - FEBRUARY 1960

POSTMASTER: If undeliverable for any reason, notify stating reason, on Form 3547 postage for which is guaranteed.

FRANK EAMES  
5 RICHARDSON AVE.  
ATTLEBORO, MASS.

Sec. 34.66 P.L. & R.  
U. S. POSTAGE  
PAID  
So. Plainfield, N. J.  
Permit No. 1

*50<sup>th</sup> Anniversary 1910-1960*



# 1960-

marks the beginning of a second half century of service of our company to the electronics and electrical industry. We are proud and grateful to our many friends throughout the world for their loyalty and support over the past 50 years. For the future we pledge our determination to continue to merit the favor of our old friends and to make many new friends and readers for our publication "the capacitor". May this year of 1960 be one of renewed health, happiness and prosperity for you and your loved ones.

Sincerely,  
CORNELL-DUBILIER ELECTRIC CORPORATION.



## INDEX TO ARTICLES

appearing in the

### 1959 ISSUES

*of the C-D Capacitor*

Transistor Network Parameters .....	Jan.-Feb.
Modern Substitution Boxes .....	Mar.-April
Servicing Transistor Audio Amplifiers .....	May-June
Survey of Solid-State Devices .....	July-Aug.
Stabilizing Transistor Circuits .....	Sept.-Oct.
Transistorized Frequency Standard .....	Nov.-Dec.

# POTENTIOMETER OPERATING DATA

A number of simple three-terminal devices are available to the electronic circuit designer. These devices are important in circuit development and testing, and are invaluable for performing such functions as voltage division, impedance matching, analog computation, stage isolation, filtration, and frequency selection. In addition, one three-terminal device, the transistor, provides amplification and can oscillate. Three-terminal devices are employed singly and in combination.

Some difference of opinion exists regarding the designation three-terminal. We apply this term to those devices which have three physical terminals; one input, one output, and one common. Some engineers insist that all input-output devices are four-terminal, and they may be in nature. However, it is easy to point out the difference. For example, a conventional transformer unquestionably is four-terminal, while an autotransformer is three-terminal in configuration.

It is impossible for a short article to cover all extant three-terminal devices, or all of the technical aspects of even a few of them. The purpose of this article is to point out the important operating characteristics of one of the most versatile of all such devices, the potentiometer, and to clear away some of the popular misconceptions held by technicians concerning its operation. We feel that the proper perspective will promote greater utility and more accurate operation of systems into which the technician frequently incorporates the potentiometer.

## D-C Potentiometer

The potentiometer is one of the simplest of three-terminal devices. Its common applications are voltage division, gain control, signal attenuation, analog computation, circuit balancing, and voltage comparison. Practical potentiometers are widely used

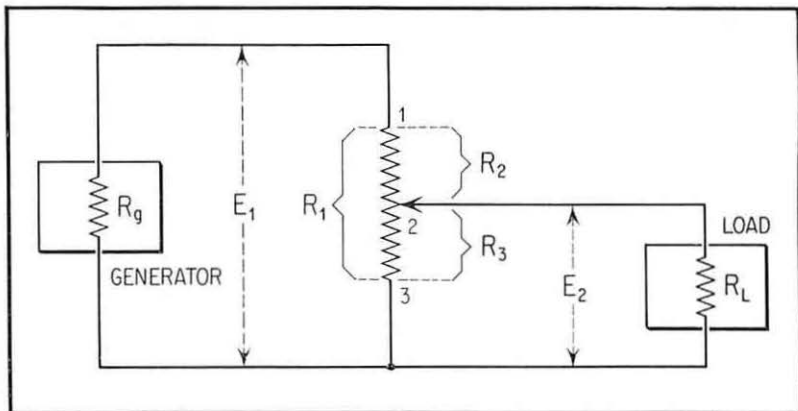

Fig. 1. Practical Circuit of Potentiometer.

in both continuously-variable and step types. In fact, there use is so common that many false assumptions are made regarding their operation and application.

Figure 1 shows the basic circuit in which the potentiometer is used. Operation of the potentiometer must always be considered with respect to its total resistance ( $R_1$ ), the resistance between its top and wiper ( $R_2$ ), resistance ( $R_3$ ) between wiper and bottom, generator (source) resistance ( $R_g$ ), and load resistance ( $R_L$ ). It is common to suppose that the potentiometer divides the input voltage ( $E_1$ ) by the ratio of  $R_3$  to  $R_2$  at any of its settings; that is, that  $E_2 = E_1 (R_3/R_1)$ . But this can be true only when  $R_1$  is very high with respect to  $R_g$ , and  $R_L$  is very high with respect to  $R_3$  (say, 100:1 in each case). Otherwise,  $R_L$  in parallel with  $R_3$  will reduce the resistance between Points 2 and 3 to less than the value indicated by the potentiometer setting. The input voltage ( $E_1$ ) at Point 1 is reduced by the factor  $R_1/(R_g + R_1)$ . The error in the latter instance may be eliminated, of course, by actually measuring  $E_1$  with a voltmeter. The voltage division is:

$$(1) \quad E_2 = E_1 \left\{ \frac{R_2 + \frac{R_3 R_L}{R_3 + R_L}}{R_g + R_2 + \frac{R_3 R_L}{R_3 + R_L}} \right\} \times$$

$$\left\{ \frac{\frac{R_3 R_L}{R_3 + R_L}}{R_2 + \frac{R_3 R_L}{R_3 + R_L}} \right\}$$

A second misconception is that the output resistance (impedance),  $R_o$ , of the potentiometer is equal simply to the resistance included between Points 2 and 3 at any setting; that is, is equal to  $R_3$ . This could be true only if  $R_g$  were very high with respect to  $R_1$ , which is almost never the potentiometer-generator relationship. Otherwise, the resistance looking back into the complete circuit must be the parallel combination of  $R_3$  and the sum of  $R_2$  and  $R_g$ , and this is less than  $R_3$ . Thus, the output resistance is:

$$(2) \quad R_o = \frac{R_3(R_2 + R_g)}{R_3 + (R_2 + R_g)}$$

This assumes that  $R_L$  is very high and accordingly does not load  $R_3$  appreciably.

It is important to note that the highest value of  $R_o$  is reached when the setting (Point 2) is such that  $R_2 = \frac{1}{2} R_1$ . When the wiper is at the top of the potentiometer (Point 1),  $R_o$  falls approximately to the value of  $R_g$ , when  $R_1$  is much higher than  $R_g$ . And when the wiper is at the bottom (Point 3),  $R_o$  falls to zero. Thus, if  $R_1$  is a 10,000-ohm potentiometer winding connected to a signal generator having 50 ohms output resistance ( $R_g$ ) and the load resistance ( $R_L$ ) is very high (e.g., a vtvm, oscilloscope, or grid input of a voltage amplifier stage), the circuit output resistance,  $R_o$ , has the following values (from Equation 2): zero at Point 3, 2512  $\Omega$  at Point 2 (the midpoint of the potentiometer range), and 49.75  $\Omega$  at Point 1. Applying Equation (1) to the same example, we find, however, that the output voltage ( $E_2$ ) at the midpoint of the potentiometer range (where  $R_2 = R_3 = 5000 \Omega$ ) still is approximately  $\frac{1}{2} E_1$  when  $R_L$  is assumed 1 megohm. (To be exact,  $E_2 = 0.498E_1$ .)

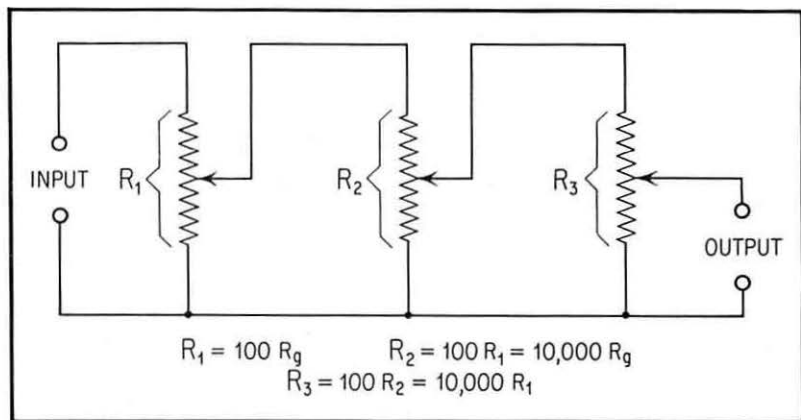

Fig. 2. Cascaded Potentiometers.

A third misconception is that the input resistance (impedance),  $R_i$ , of the potentiometer is the total potentiometer winding resistance,  $R_1$ . This could be true only if  $R_L$  were extremely high so as to impose virtually no load upon the potentiometer. Otherwise, the resistance looking into the potentiometer must be the sum of  $R_2$  in series with the parallel combination of  $R_3$  and  $R_L$  which will make  $R_i$  less than  $R_1$ . Thus, the input resistance is:

$$(3) \quad R_i = R_2 + \frac{R_3 R_L}{R_3 + R_L}$$

Again using the example of the 10,000-ohm potentiometer with a 1-megohm load, we can determine by means of Equation (3) that the input resistance,  $R_i$ , is 9901  $\Omega$  when the wiper is at the top (Point 1) of the potentiometer, and is 9975  $\Omega$  when the wiper is at the midpoint (Point 2) where  $R_2 = R_3 = 5000 \Omega$ . If  $R_L$  is reduced to 10,000 ohms, the value of  $R_i$  when the wiper is at Point 1 drops

to 5,000  $\Omega$  and to 8333  $\Omega$  when the wiper is at the midpoint.

The foregoing discussion and examples show in simple quantitative terms the importance of selecting  $R_1$  high with respect to  $R_g$ , and  $R_L$  high with respect to  $R_1$ . When potentiometers are cascaded, as in Figure 2, and their settings are to be read from resistance-calibrated dials, each successive potentiometer will introduce minimum loading error on the preceding one when its total resistance,  $R_i$ , is much higher than that of its predecessor. In the 3-potentiometer arrangement shown,  $R_1$  is at least  $100 R_g$ ,  $R_2 = 100 R_1 = 10,000 R_g$ , and  $R_3 = 100 R_2 = 10,000 R_1$ . In practical systems where the resistance soon would become unwieldy, d-c amplifiers may be introduced between potentiometers for isolation.

#### A-C Potentiometer

Simple potentiometer circuits may be employed in a-c circuits without modification and may be treated as

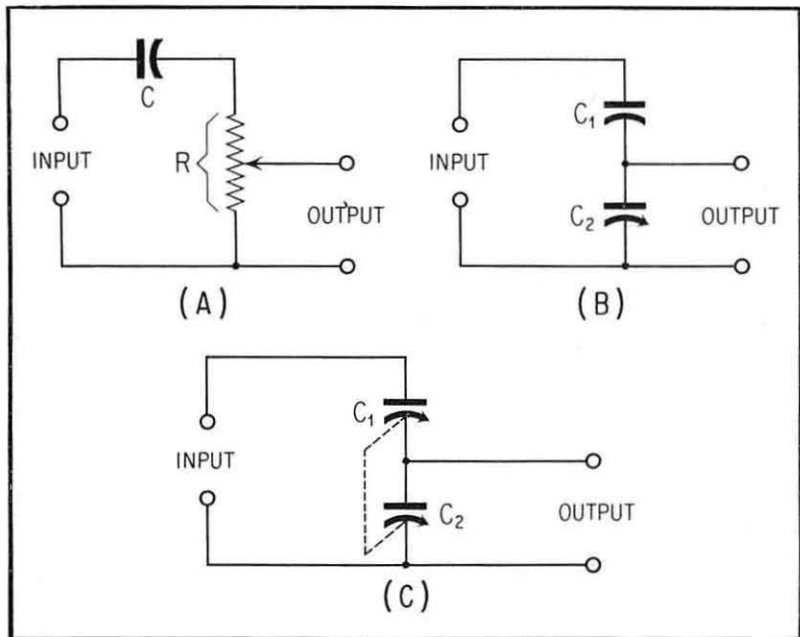

Fig. 3. A-C Potentiometers.

resistances when the potentiometers have negligible reactive components. High-resistance, wirewound units often have appreciable inductance, however, and the resulting impedance at the operating frequency accordingly must be taken into account.

In simple a-c circuits, the potentiometer often is connected in series with a blocking capacitor, as in Figure 3(A) for purposes of d-c isolation. When this is done, Capacitance  $C$  must be chosen such that its reactance at the operating frequency is very low with respect to Resistance  $R$ . This has a twofold advantage. The voltage drop across the capacitor is minimized, as also the phase shift introduced by RC combination. Thus, for 1000-cycle

operation where  $R$  must be 0.2 megohm,  $C$  may be chosen  $0.1 \mu\text{fd}$ . In this instance, the phase shift will be less than 1 degree and the attenuation better than 0.999.

Capacitive potentiometers are advantageous in some systems, especially at radio frequencies. The voltage division is proportional to the ratio of the reactances in the series string. Figure 3(B) shows one arrangement in which the input capacitor  $C_1$  (corresponding to Resistor  $R_2$  in the resistive potentiometer, Figure 1) is fixed, and the output capacitor  $C_2$  (corresponding to Resistor  $R_3$ ) is variable. The fixed reactance of  $C_1$  limits the maximum value of the output



voltage. Furthermore, the input impedance of the potentiometer varies as the setting of  $C_2$  is changed.

Figure 3(C) shows a continuously-variable capacitive potentiometer which does not have the maximum-limiting disadvantage of the unit illustrated by Figure 3(B). In this circuit, a 2-gang variable capacitor,  $C_1$ - $C_2$ , is so constructed that  $C_1$  is at maximum capacitance when  $C_2$  is at minimum, and vice versa. A constant value of input impedance therefore is presented to the

generator. That is, the capacitance looking in from the input terminals is constant, while the output capacitance is variable.

Capacitance-type a-c potentiometers introduce a problem when they are connected to inductive generators or loads, since they form tuned circuits with these devices. Before selecting the capacitive elements for such potentiometers, the possibility of troublesome resonance at the operating frequency or its important harmonics

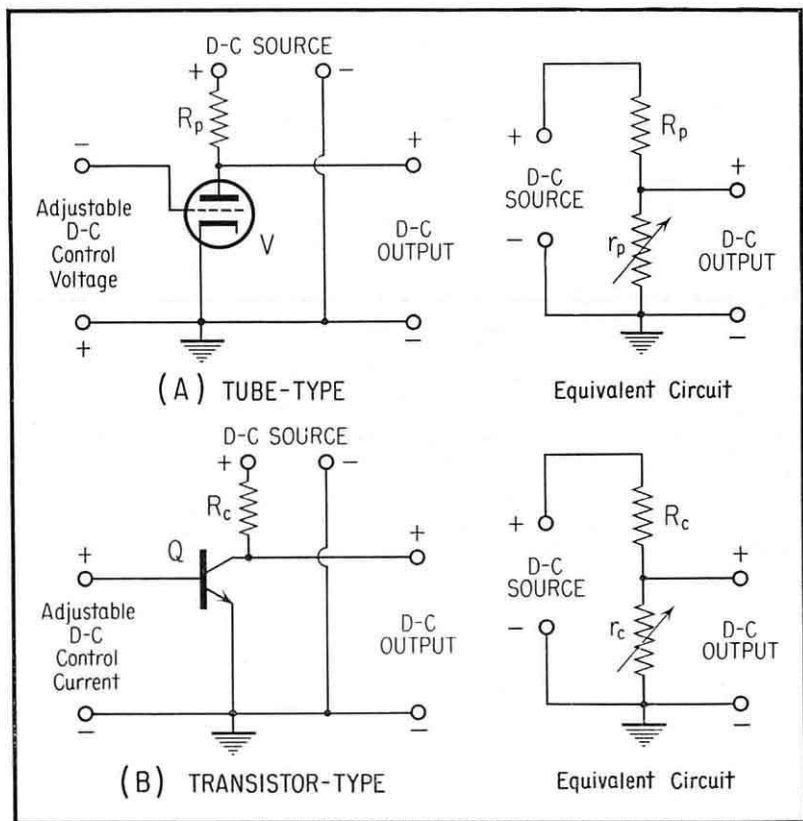

Fig. 4. Active Potentiometers.

accordingly must be investigated. Unlike their d-c counterpart, a-c potentiometers require shielding when they are used at frequencies higher than audio. At most radio frequencies, the shielding must be extensive and stray capacitances within the potentiometer must be eliminated or minimized.

#### Active Potentiometer

By utilizing the variable output resistance of an active element (tube or transistor), an electrically-controlled potentiometer having high control sensitivity may be obtained. Figure 4 shows circuits of active potentiometers of the two types.

In Figure 4(A), the d-c voltage which is to be divided by the potentiometer supplies the plate potential of the triode tube,  $V$ , through the external plate resistor,  $R_p$ . The latter is in series with the internal plate-cathode resistance,  $r_p$ , of the tube, as shown by the equivalent circuit. An adjustable d-c voltage applied between grid and cathode, with the grid negative, varies  $r_p$  from a high value (corresponding to grid cutoff voltage) to a low value (determined by the plate current flow which, in turn, is a function of the source voltage and  $R_p$ ). If the external load resistance is very high with respect to  $r_p$ , the junction of  $R_p$  and  $r_p$  rises approximately to the source voltage, when the tube is cut off. When the tube is conducting, this junction voltage drops to a much lower value. When  $V$  is a high-transconductance tube, a small change in grid control voltage produces a large shift in resistance  $r_p$ . By reversing the control-voltage polarity, so that the grid is positive, large values of plate current ( $i_p$ ) will flow, and the junction will fall to a still lower voltage, as a result of the drop,  $i_p R_p$ , across the external plate resistor,  $R_p$ .

In Figure 4(B), the d-c voltage which is to be divided by the potentiometer supplies the collector potential of the transistor,  $Q$ , through the external collector resistor,  $R_c$ . The latter is in series with the internal collector-emitter resistance,  $r_c$ , as shown by the equivalent circuit. An adjustable d-c current applied to the base-emitter circuit of the transistor, with the base of the NPN transistor positive, varies  $r_c$  from a high value (corresponding to cutoff, when the control current is zero) to a low value (determined by the collector current flow which, in turn, is a function of the source voltage and  $R_c$ ). If the external load resistance is very high with respect to  $R_c$ , the junction of  $R_c$  and  $r_c$  rises approximately to the source voltage when the transistor is cut off. When the transistor is conducting, this junction voltage drops to a much lower value. With a high-beta transistor, the control current will be only a few microamperes, and a small change in this current will produce a large shift in the resistance  $r_c$ .

The active potentiometer suffers from its inability to be reduced to zero output resistance. The reason for this is that neither the tube nor the transistor can safely carry currents high enough to attain this state. However, resistances as low as a few tenths of an ohm may be reached with some transistors. Within its limitations, the active potentiometer is advantageous in automatic systems in which a small control voltage or current is utilized to control or stabilize operations of various sorts. Typical applications are voltage regulators, current regulators, automatic output attenuators, automatic and manual speed controls, temperature controls, light dimmers, and servo-mechanisms.