

SELENIUM RECTIFIER *handbook*



INC.

50¢

CATALOG NO. A-1

RECTIFIER DIVISION, BLOOMINGTON, INDIANA

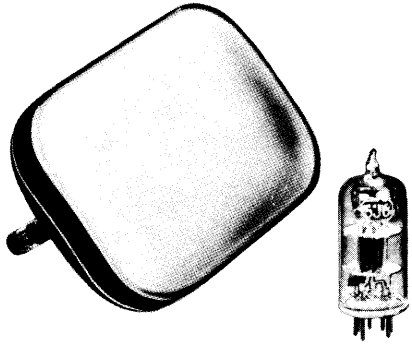

CATHODE RAY & RECEIVING TUBES

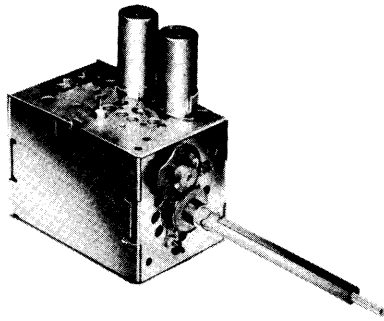

TELEVISION TUNERS

WTTV

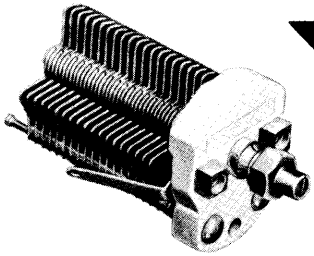

AIR TRIMMERS

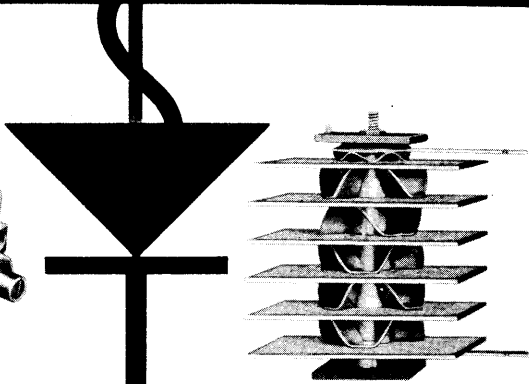

SELENIUM RECTIFIERS

WTTTS

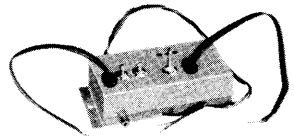

SINGLE BAND UHF TRANSLATOR

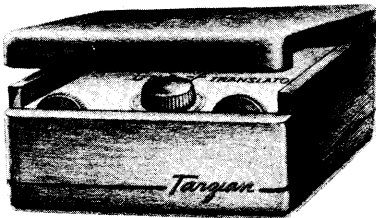
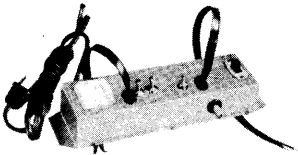

FULL RANGE UHF TRANSLATOR

Our Pledge

To give you sound engineering, high quality, smooth service and dependable production to the best of our ability:

G. J. Eannarino
G. J. EANNARINO, Director

S. Niciejewski
S. NICIEJEWSKI, Sales Manager

E. G. Cameron
E. G. CAMERON, Works Manager

Walter Petrosky
WALTER PETROSKY, Production Superintendent

E. W. Chadwick
E. W. CHADWICK, Chief Engineer

Robert C. Parsons
R. C. PARSONS, Chief Chemist

Robert T. Everett
R. T. EVERETT, Asst. Chief Chemist

F. T. Zoerner
F. T. ZOERNER, Chief Quality Control



SELENIUM RECTIFIER Handbook

SECTION 1—Page 4

Selenium Rectifiers for
Radio, Television and
Electronic Application

SECTION 2—Page 49

Power Rectifiers

High Voltage Rectifiers

SECTION 3—Page 74

Selenium Rectifier
Replacement Guide

Copyright 1950 by
Sarkes Tarzian, Inc.

*Sarkes Tarzian, Inc. assume no patent
liability with respect to commercial ap-
plication of the circuits contained herein.*

F O R E W O R D

The Selenium Rectifier has long been accepted as an efficient, long lived means of converting alternating current to direct current in industrial applications with relatively large power requirements. During the past four years the field of application of selenium rectifiers was expanded to include radio and television receivers as well as all types of electronic and mobile equipment. Many millions of units are now in use in these applications.

Perhaps the greatest factors in this tremendous expansion have been the application of mass production techniques and rapid advance in engineering. The result has been a high quality product at low cost.

The Sarkes Tarzian organization includes a staff of expert engineers who thoroughly investigate each application in the laboratories before submitting recommendations. Also, constant research is being carried on to maintain the quality of production and develop rectifiers with higher inverse voltage ratings.

The entire facilities of the Sarkes Tarzian engineering department are available to assist you with your problem. A letter, telegram or phone call will result in a prompt reply.

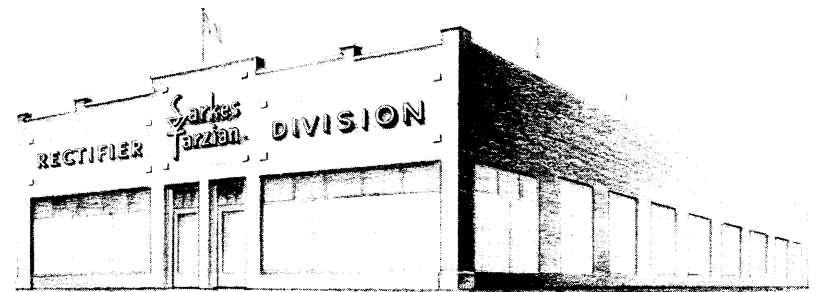

SECTION 1

DIMENSIONAL DIAGRAM

The dimensional diagram shown below is to be used for the determination of the dimensions of "Centre-Kooled" Selenium Rectifiers for radio, television and general electronic use. Unless otherwise indicated, the specified dimensions are maximum.

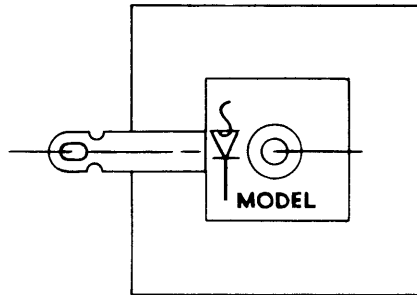

POSITIVE TERMINAL
(RED)

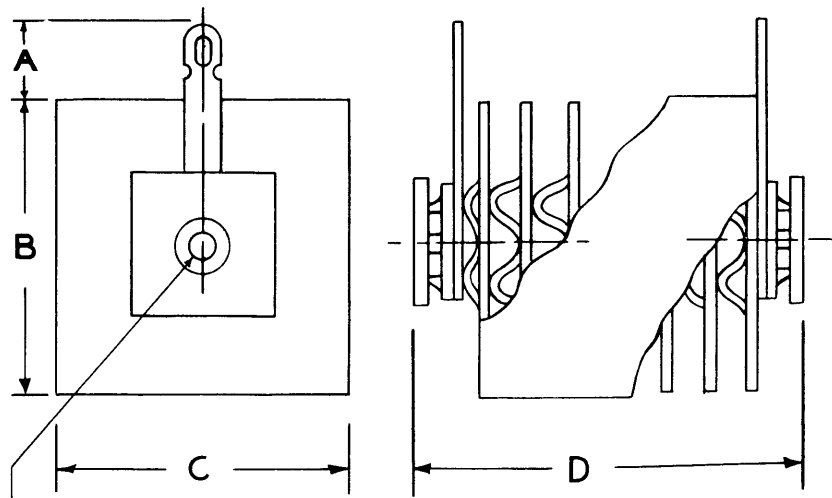

CLEARANCE FOR
No. 8 MACHINE SCREW

NEGATIVE TERMINAL
(YELLOW)

SIDE VIEW

SUGGESTED MOUNTING METHODS

STUD MOUNTING

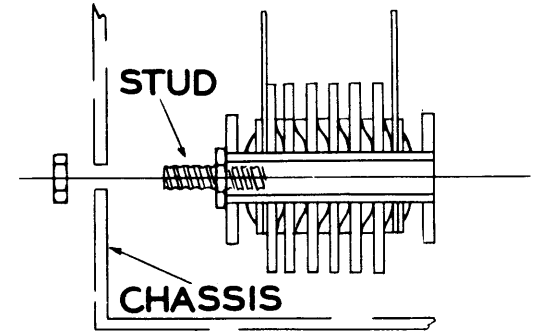

STUD MOUNTING WITH LOCKING LUG

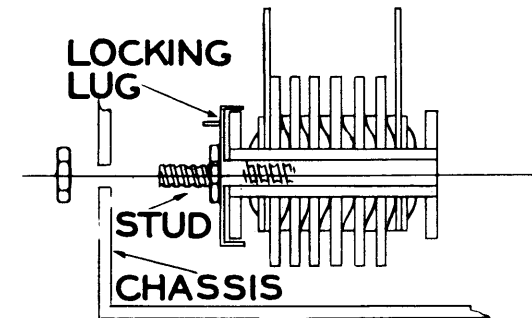

LOCKING LUG BOLT MOUNTING

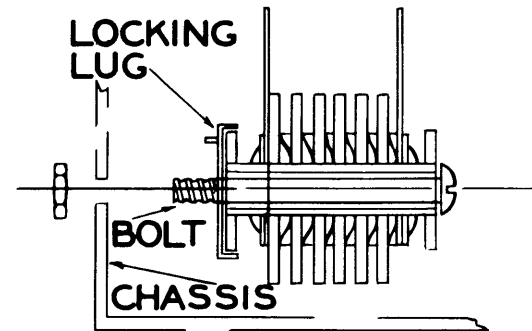

Typical Circuits Using SELENIUM RECTIFIERS

The radio "Centre-Kooled" selenium rectifier has found wide application in all phases of radio, television and electronic design. This versatile unit has completely changed concepts of D. C. power supply design. Where it had previously been considered impractical to use voltage multiplier circuits because of complicity of supplying power to the filaments, the selenium rectifier is now in wide use in voltage doubler, voltage tripler and voltage quadrupler circuits. Voltage multipliers eliminate the need for a power transformer as well as a rectifier tube. The high efficiency, cool operation, compactness and light weight of selenium rectifiers have made them popular in television receivers, all types of radio receivers and many electronic equipments.

HALF WAVE RECTIFIER

The simplest single phase Selenium Rectifier power supply, shown in figure 1, requires only a single rectifier and an electrolytic capacitor. Since the rectifier in this circuit conducts only when the upper A. C. input terminal is positive the first filter capacitor is charged only once during each cycle of the supply voltage. The ripple frequency therefore is equal to the supply voltage frequency. For this reason it is recommended that somewhat larger values of components in the filter network than would normally be required in a circuit in which the input capacitor is charged during each half cycle and the ripple frequency thereby double that of the input frequency.

When the rectifier is conducting during the half cycle the upper A. C. terminal is positive, the first filter capacitor, C_1 , will become charged instantaneously to the peak of the A. C. input voltage (less the conducting voltage drop through the rectifier) and maintain the D. C. voltage during the negative half cycle. The average D. C. voltage across C_1 is dependent on two factors, (1) The microfarad value of the input capacitor, and (2) the milliamperes of current drawn by the load. A larger value of filter capacity also improves voltage regulation while decreasing the ripple component.

The function of R_1 (Fig. 1), the surge limiting resistor, is to minimize the large surge currents prevalent in half wave circuits. Current flowing through R_1 causes a voltage drop which is greatest when the surge current reaches its peak and assumes a steady value when, after the first few cycles, the capacitor becomes fully charged. R_1 also acts as a fuse in the circuit and protects relatively expensive components in the event of a short circuit across the load.

Voltage regulations of 15 to 20% may be realized depending on choice of components and load current. The nominal voltage drop in a typical radio type selenium rectifier rated at 130 volts A. C. input is approximately 5 volts.

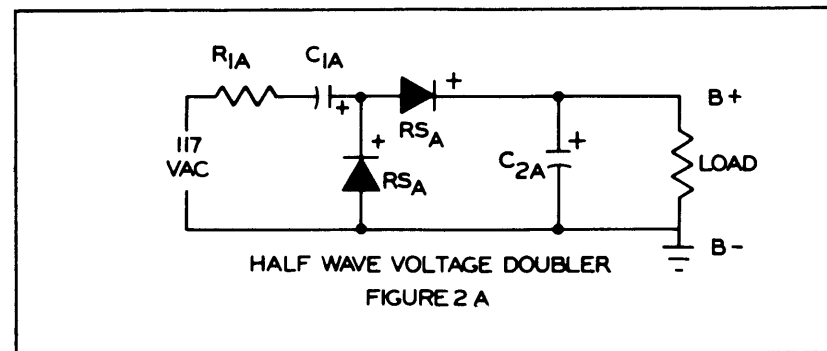
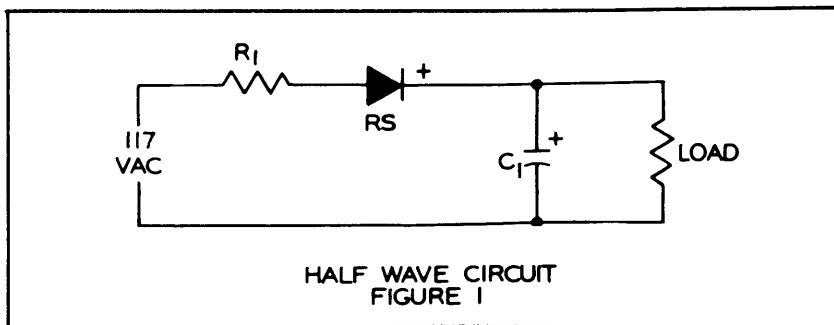

VOLTAGE DOUBLER

The voltage doubler is the most frequently used transformerless voltage multiplier circuit. The no load D. C. output voltage of a voltage doubler circuit is 2.82 times the RMS value of the input voltage.

The design engineer can choose between two types of voltage doubler circuits. The half wave voltage doubler is shown in figure 2A; the full wave or symmetrical voltage doubler in figure 2B. The half wave circuit has the advantage that one side of the A. C. supply is common with the negative D. C. output, thereby minimizing hum difficulties and secondly, it is not necessary to use identical capacitors in the doubler circuit. In the full wave or symmetrical voltage doubler circuit the negative D. C. terminal can not be made common to one side of the A. C. supply and this increases the possibilities of hum in high gain amplifiers. The advantages of the full wave or symmetrical voltage doubler are: lower ripple component; better voltage regulation and ripple frequency double that of the A. C. supply. It is important that the capacities of C_{1B} and C_{2B} are kept as nearly equal as possible to keep the load divided equally between the two rectifiers.

The functions of R_{1A} and R_{1B} in the voltage doubler circuits are identical to those of R_1 in the half wave circuit; to limit the initial surge current while the capacitor is being charged and to act as a fuse in the event a short circuit is caused across the load.

Maximum voltage regulation and minimum ripple are acquired by use of large values of capacity.

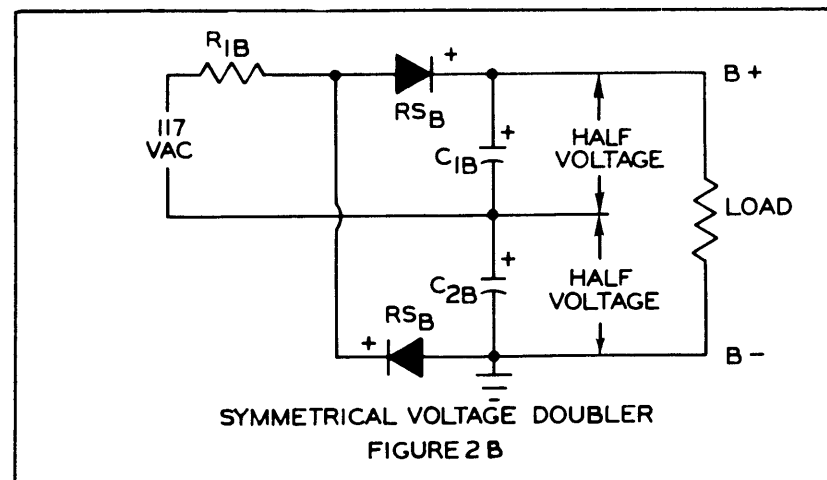

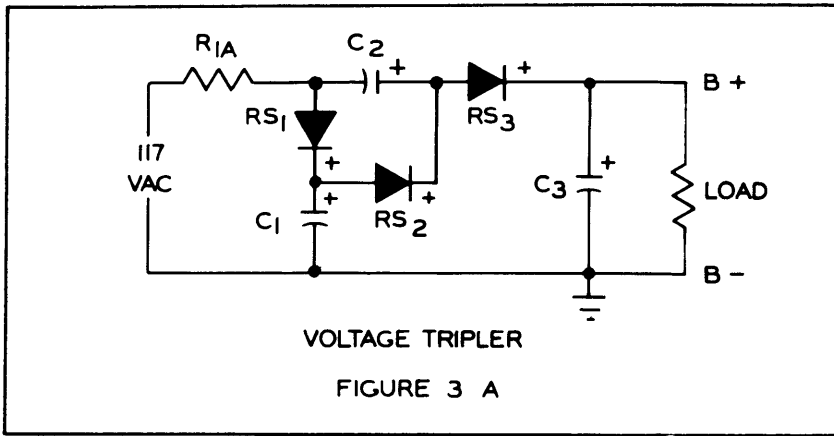

VOLTAGE TRIPLER

Although less popular than the voltage doubler circuits, the voltage tripler has found application where voltages in excess of those delivered by voltage doublers are required. The typical half wave voltage tripler is illustrated in figure 3A. The modified form of the voltage tripler illustrated in figure 3B has been widely used in television receivers to develop bias voltage for the cathode ray tube as well as provide nominal B+ voltage to power the set. The rating of RS_3 in the circuit need be only as large as the current requirement, usually in the order of 50 to 65 milliamperes. The values of RS_1 and RS_2 will depend on the current drawn by the tube complement of the receiver.

The voltage regulation and ripple percentage of the circuit depend on the values of capacitance used. R_{1A} and R_{1B} act as surge limiting resistors.

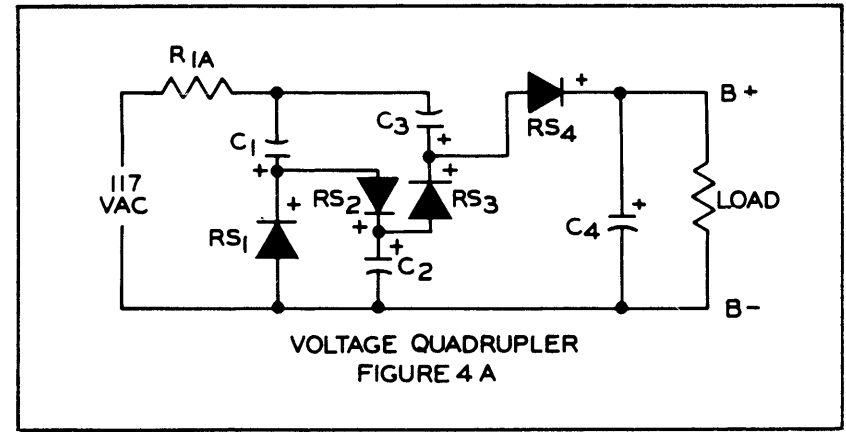
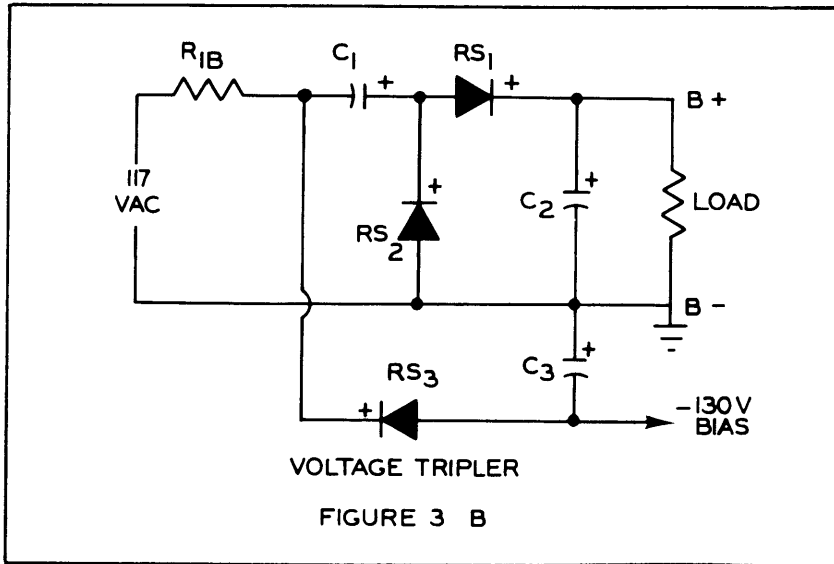

VOLTAGE QUADRUPLER

Theoretically it is possible by adding successive stages of rectifier-condenser combinations, to multiply the source voltage to infinite values; however, from economic and efficiency standpoints the practical limit in commercial applications of voltage multiplier circuits is the voltage quadrupler. The voltage quadrupler will deliver, under no load conditions, an approximate D. C. output voltage 5.65 times the RMS value of the source voltage. Figure 4A shows a typical voltage quadrupler circuit in which the negative D. C. terminal is connected to one side of the A. C. supply. Figure 4B shows a quadrupler circuit in common use wherein equal outputs are delivered both above and below chassis potential.

Large values of capacitance are required for low ripple and good regulation.

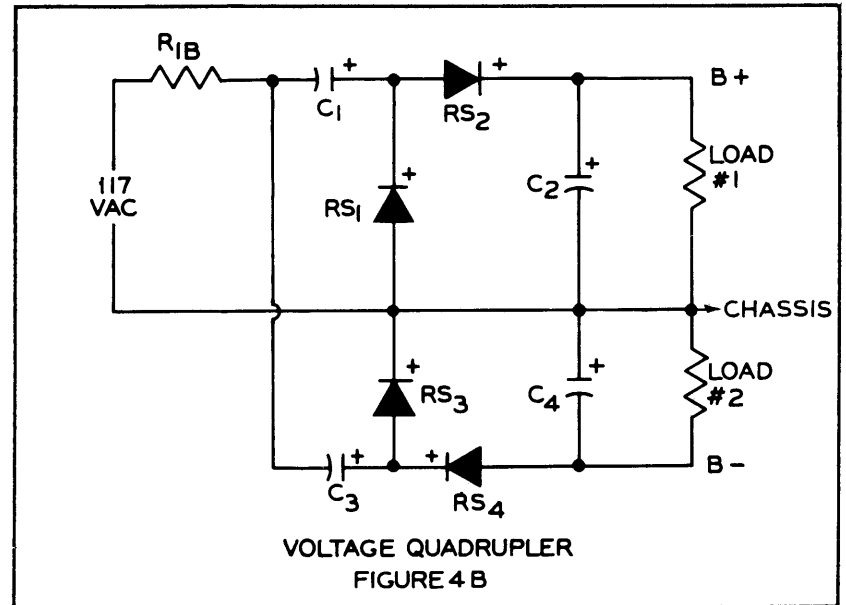

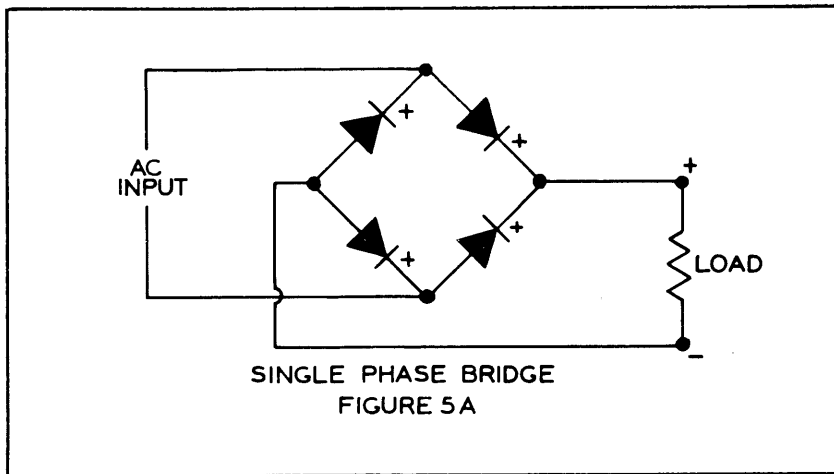

BRIDGE RECTIFIER

The bridge rectifier, Fig. 5, is recommended for use in equipments which require extremely good regulation and small ripple voltage components in the output. High ripple frequency and rectification during each half of the input voltage cycle allow the use of relatively low values of filter components. The efficiency of a single phase bridge, Fig. 5A, is approximately 70 percent and approximately 90 percent in a three phase bridge, Fig. 5B. Although commonly used in applications where relatively high currents are required it is possible nonetheless to connect four standard half wave radio type rectifiers into a bridge circuit for electronic equipment.

Many suggested applications are listed in this manual; however, these represent only a small portion of possible applications and circuits. It is being left to the ingenuity of the engineer and technician to develop circuits to fit his applications from the suggestions contained herein.

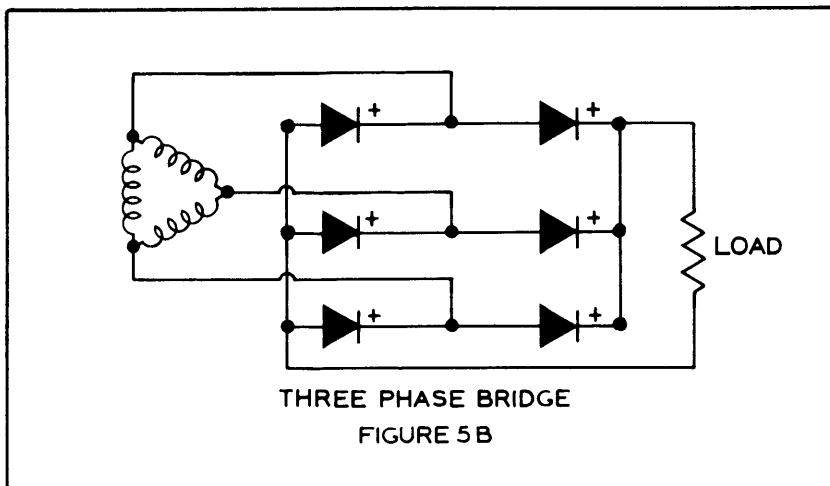

**Sarkes
Tarzian**
"Centre-Cooled"
SELENIUM RECTIFIER
Model 35
35 MA 130V Max.

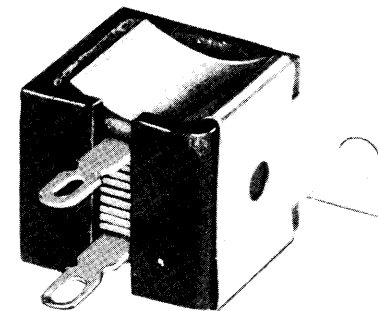

CHARACTERISTICS

Max. RMS Input Voltage.....	130	Approximate Rectifier Voltage Drop.....	8
Max. Inverse Peak Voltage.....	380	Minimum Series Resistance (Ohms).....	47
Max. Peak Current (MA).....	350	Max. Operating Plate Temperature.....	85°C
Max. RMS Current (MA).....	90		
Max. DC Current (MA).....	35		

DIMENSIONS IN INCHES

(See dimensional diagram, page 4)

A— 3/8" B— 5/8" C— 5/8" D— 5/8"

The Sarkes Tarzian Model 35 was designed to meet field requirements for a low current rectifier. The Model 35 has found wide application in television boosters and electronic control circuits.

Characteristics follow.

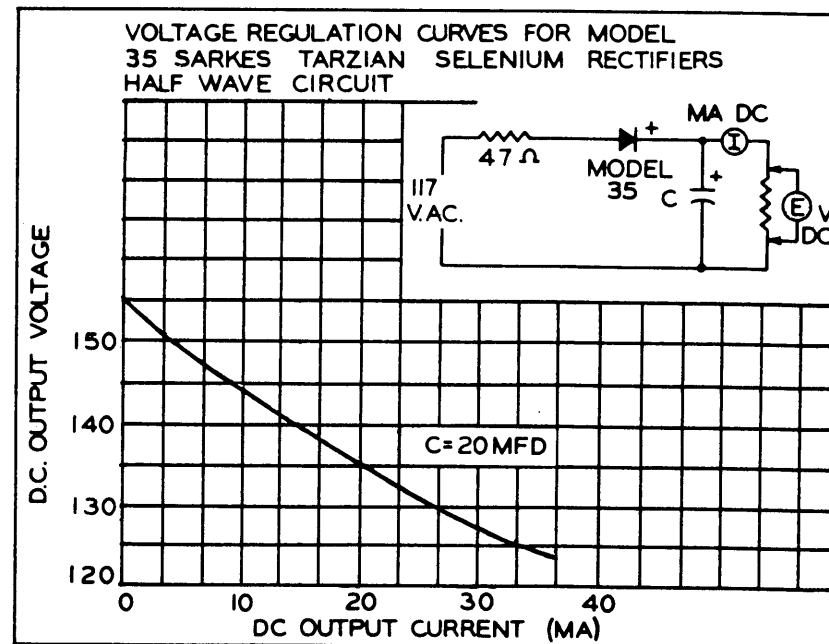

Sarkes Tarzian

"Centre-Kooled" SELENIUM RECTIFIER

Model 65

65 MA 130V Max.

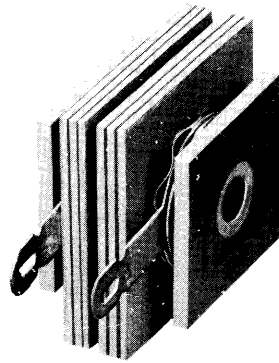

CHARACTERISTICS

Max. RMS Input Voltage.....	130	Approximate Rectifier Voltage Drop....	5
Max. Inverse Peak Voltage.....	380	Minimum Series Resistance (Ohms).....	22
Max. Peak Current (MA).....	650	Max. Operating Plate	
Max. RMS Current (MA).....	162	Temperature	85°C
Max. DC Current (MA).....	65		

DIMENSIONS IN INCHES

(See dimensional diagram, page 4)

A—13/32" B—1" C—1" D—11/16"

The Sarkes Tarzian Model 65 Centre-Kooled Selenium Rectifier is designed to meet the need for a low current rectifier suitable for one tube receivers, television boosters, phonograph oscillators, 3-way portable, 5 tube AC/DC sets, electronic devices and as a bias supply in television receivers. This rectifier provides, at low cost, the improved efficiency and sensitivity that are inherent characteristics of all power supplies using Selenium Rectifiers.

Characteristic curves follow.

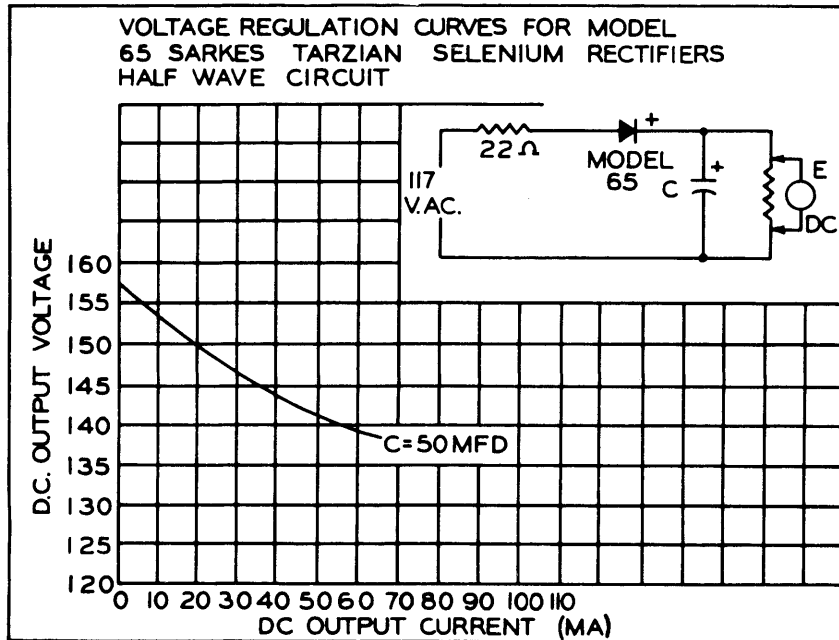

Sarkes Tarzian

"Centre-Kooled" SELENIUM RECTIFIER

Model 75

75 MA 130V Max.

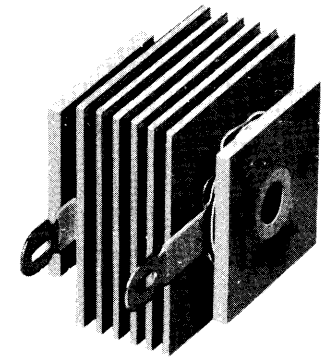

CHARACTERISTICS

Max. RMS Input Voltage.....	130	Approximate Rectifier Voltage Drop....	5
Max. Inverse Peak Voltage.....	380	Minimum Series Resistance (Ohms).....	22
Max. Peak Current (MA).....	750	Max. Operating Plate	
Max. RMS Current (MA).....	187	Temperature	85°C
Max. DC Current (MA).....	75		

DIMENSIONS IN INCHES

(See dimensional diagram, page 4)

A—13/32" B—1" C—1" D—13/16"

The Sarkes Tarzian Model 75 Centre-Kooled Selenium Rectifier is to be used in applications requiring more than 65 milliamperes, or in sets with high ambient temperature conditions. It is particularly adapted to use in large three-way portable radios that normally use five or more tubes. The instant starting feature of Selenium Rectifiers has made them popular in portable radios since the set starts at once in the AC/DC position, as well as in the battery position.

Characteristics follow.

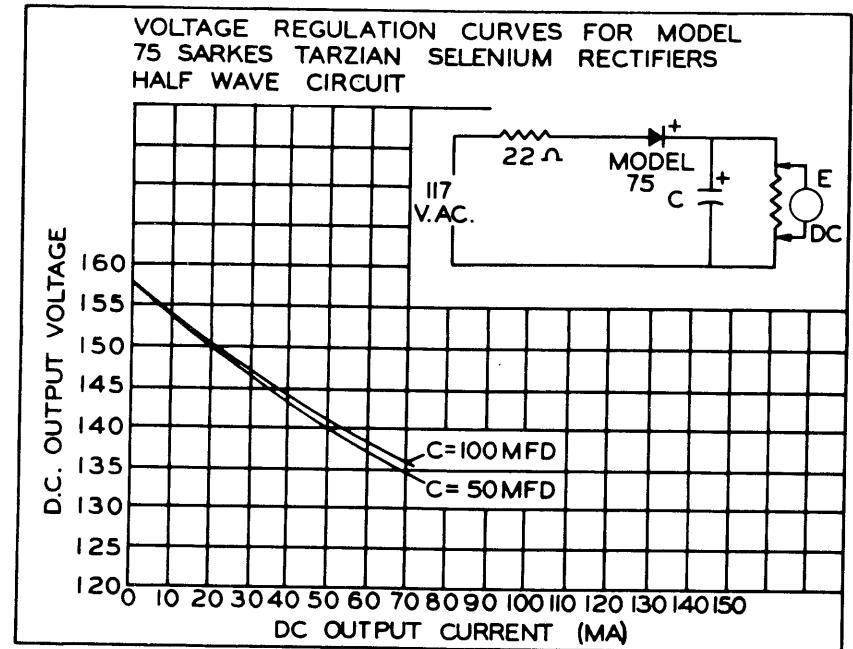

**Sarkes
Tarzian**

"Centre-Kooled"
SELENIUM RECTIFIER

Model 100

100 MA 130V Max.

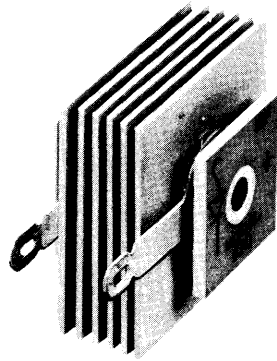

CHARACTERISTICS

Max. RMS Input Voltage.....	130	Approximate Rectifier Voltage Drop....	5
Max. Inverse Peak Voltage.....	380	Minimum Series Resistance (Ohms).....	22
Max. Peak Current (MA).....	1000	Max. Operating Plate	
Max. RMS Current (MA).....	250	Temperature	85°C
Max. DC Current (MA).....	100		

DIMENSIONS IN INCHES

(See dimensional diagram, page 4)

A—13/32" B—1.25" C—1.25" D—13/16"

The Sarkes Tarzian Model 100 Centre-Kooled Selenium Rectifier is ideal for use in table model AM-FM receivers or combination phonograph sets which do not require more than 100 milliamperes from the B-power supply.

As is true of all Selenium Rectifiers, it is also adaptable in countless electronic applications, such as electric shavers, etc., where a DC potential is either desirable or required.

Characteristic curves follow.

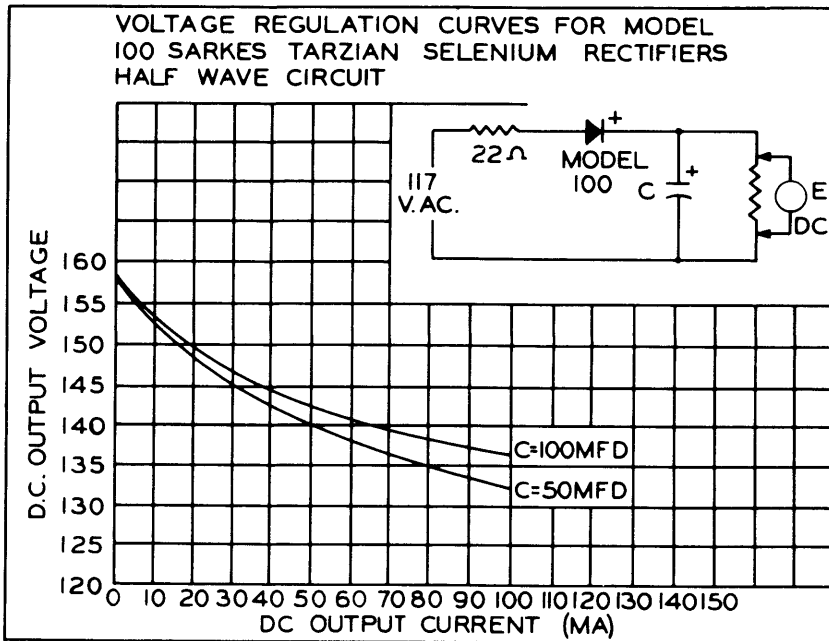

**Sarkes
Tarzian**

"Centre-Kooled"
SELENIUM RECTIFIER

Model 100A

100 MA 130V Max.

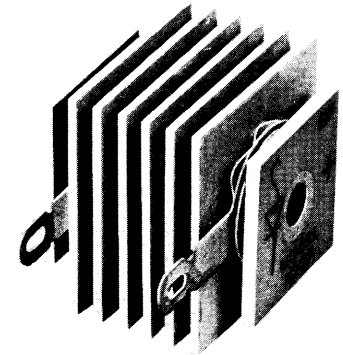

CHARACTERISTICS

Max. RMS Input Voltage.....	130	Approximate Rectifier Voltage Drop....	5
Max. Inverse Peak Voltage.....	380	Minimum Series Resistance (Ohms).....	22
Max. Peak Current (MA).....	1000	Max. Operating Plate	
Max. RMS Current (MA).....	250	Temperature	85°C
Max. DC Current (MA).....	100		

DIMENSIONS IN INCHES

(See dimensional diagram, page 4)

A—13/32" B—1" C—1" D—1"

Designed to meet the same duty and load conditions as the standard Model 100, the Sarkes Tarzian Model 100A has found wide application in sets and devices where space is at a premium. Although smaller in size, the Model 100A has been thoroughly engineered under the same rigid standards that govern all Sarkes Tarzian rectifiers and will give long life and excellent performance when operated within its ratings.

Characteristic curves follow.

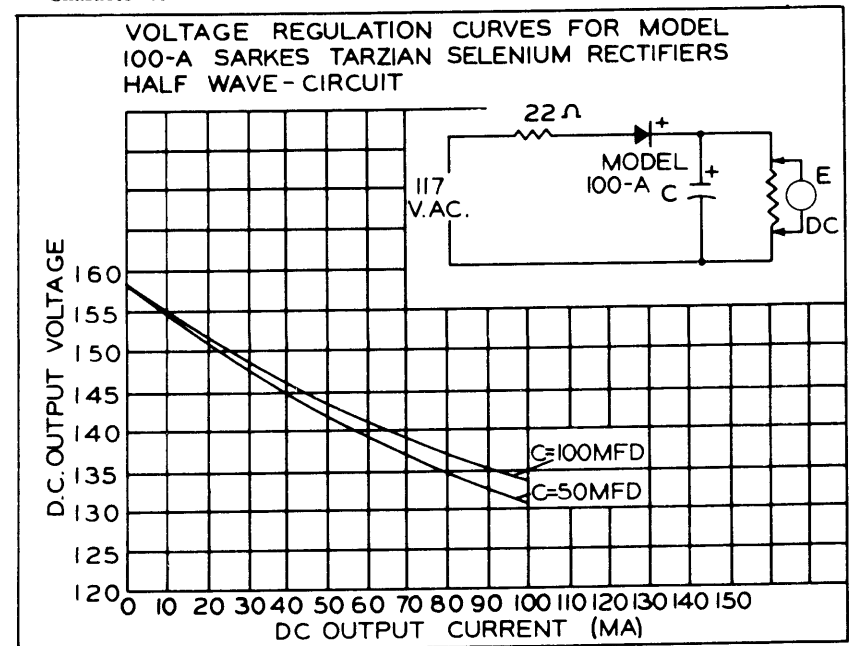

Sarkes Tarzian

"Centre-Cooled" SELENIUM RECTIFIER

Model 150

150 MA 130V Max.

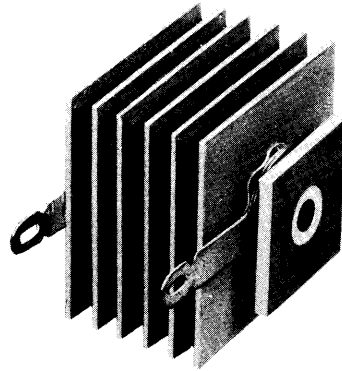

CHARACTERISTICS

Max. RMS Input Voltage.....	130	Approximate Rectifier Voltage Drop....	5
Max. Inverse Peak Voltage.....	380	Minimum Series Resistance (Ohms).....	15
Max. Peak Current (MA).....	1500		
Max. RMS Current (MA).....	375	Max. Operating Plate	
Max. DC Current (MA).....	150	Temperature	85°C

DIMENSIONS IN INCHES

(See dimensional diagram, page 4)

A—13/32" B—1.25" C—1.25" D—1 11/64"

The medium current handling capabilities of the Sarkes Tarzian Model 150 have made it ideal in console radio receivers, combination AM-FM phonograph sets and in cascade voltage multiplier circuits in 7 inch television receivers.

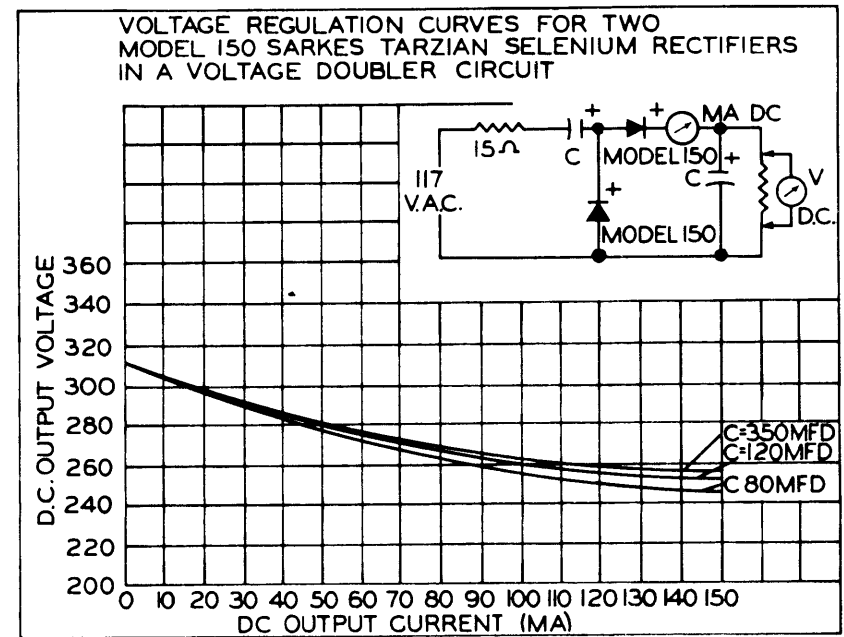
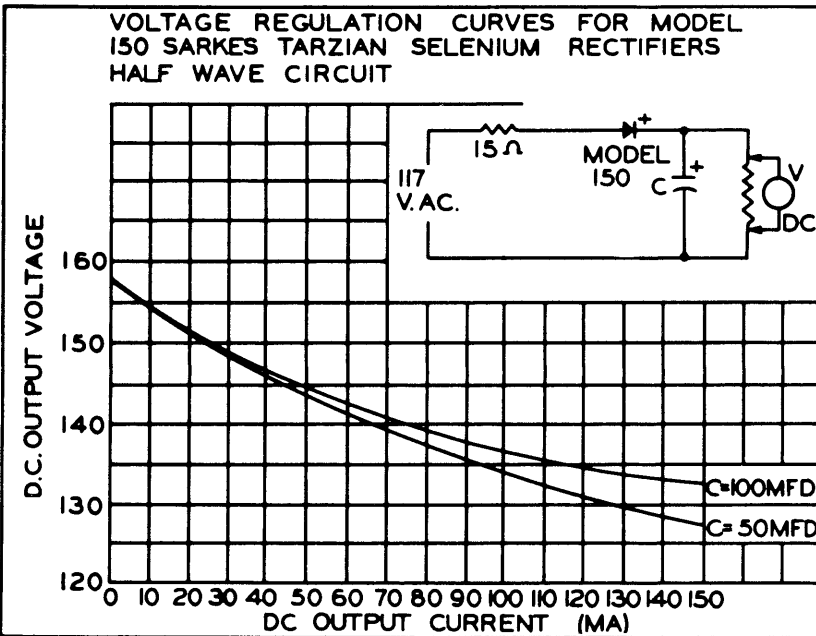

The long life, high efficiency and trouble-free operation typical in all Selenium Rectifier power supplies have made the Model 150 Rectifier popular in the larger radio and small television sets.

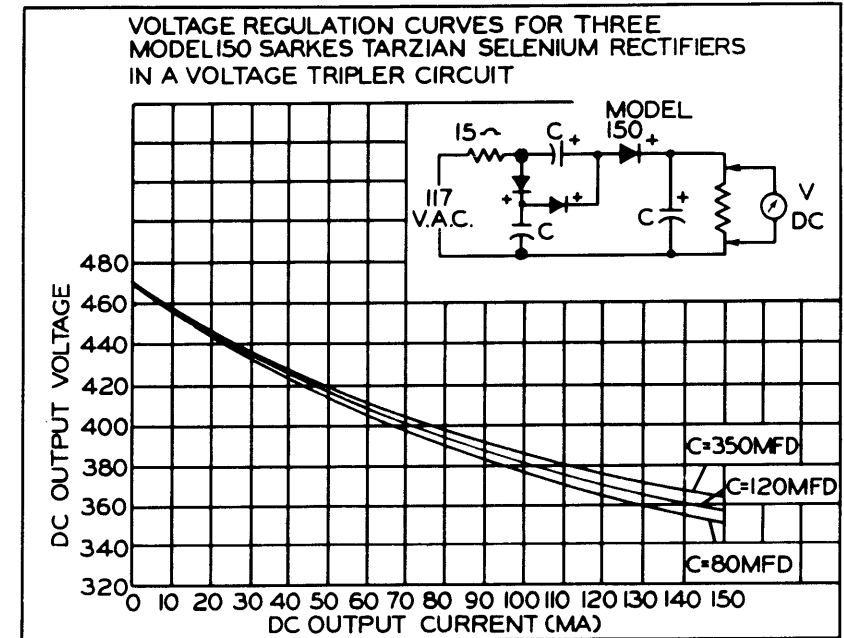



"Centre-Kooled"
SELENIUM RECTIFIER

Model 200

200 MA 130V Max.

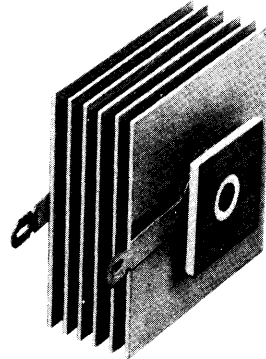

CHARACTERISTICS

Max. RMS Input Voltage.....	130	Approximate Rectifier Voltage Drop....	5
Max. Inverse Peak Voltage.....	380	Minimum Series Resistance (Ohms).....	5
Max. Peak Current (MA).....	2000		
Max. RMS Current (MA).....	500	Max. Operating Plate	
Max. DC Current (MA).....	200	Temperature	85°C

DIMENSIONS IN INCHES

(See dimensional diagram, page 4)

A—13/32" B—1.6" C—1.6" D—1"

The advent of television on the American scene and its immense popularity have made the Sarkes Tarzian "Centre-Kooled" Selenium Rectifiers for television familiar

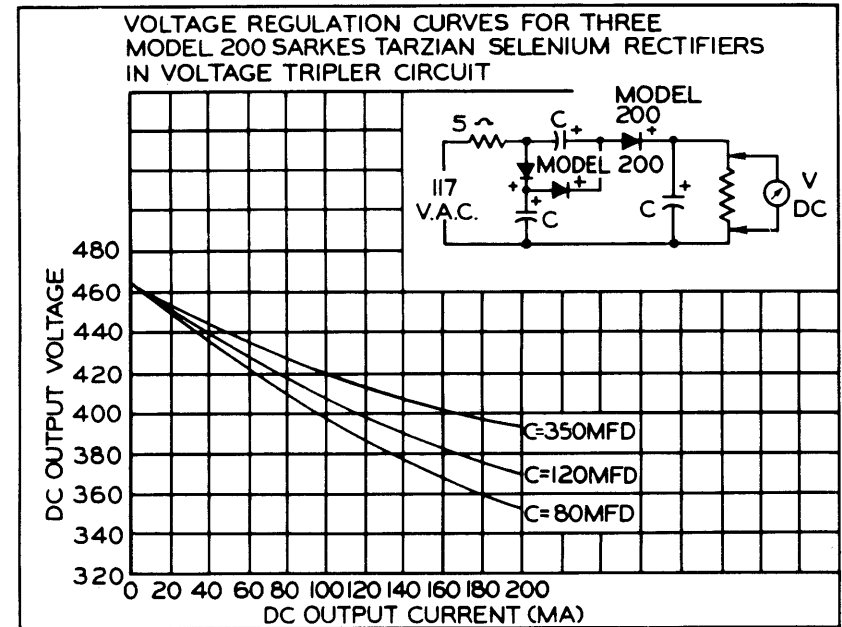
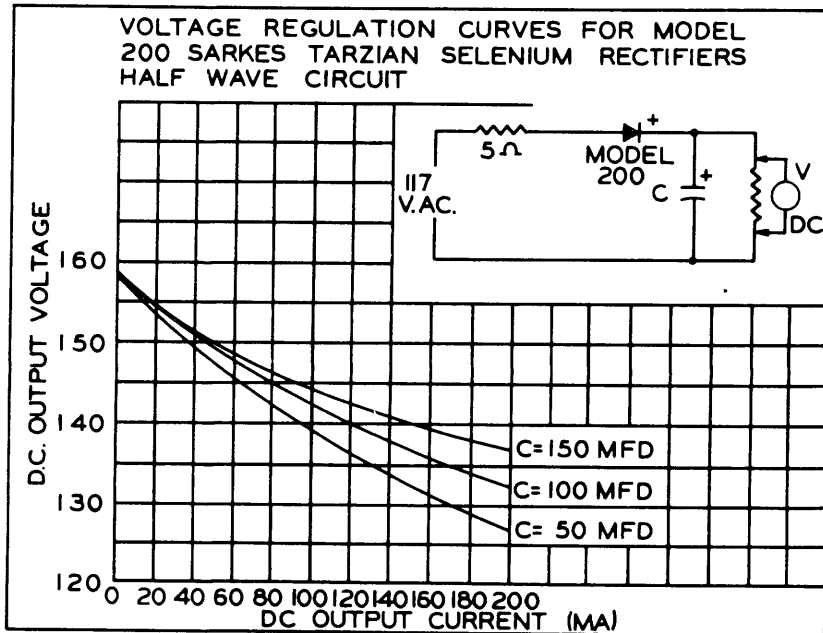

components in many television receivers. The Model 200 Rectifier is designed and engineered to meet the requirements of 7" and 10" television receivers, both in current handling capacity and temperature rise above ambient conditions. By the use of Model 200 Rectifiers in the power supply, the television manufacturer can decrease the size, cost and weight of his receiver and provide improved performance and long life.

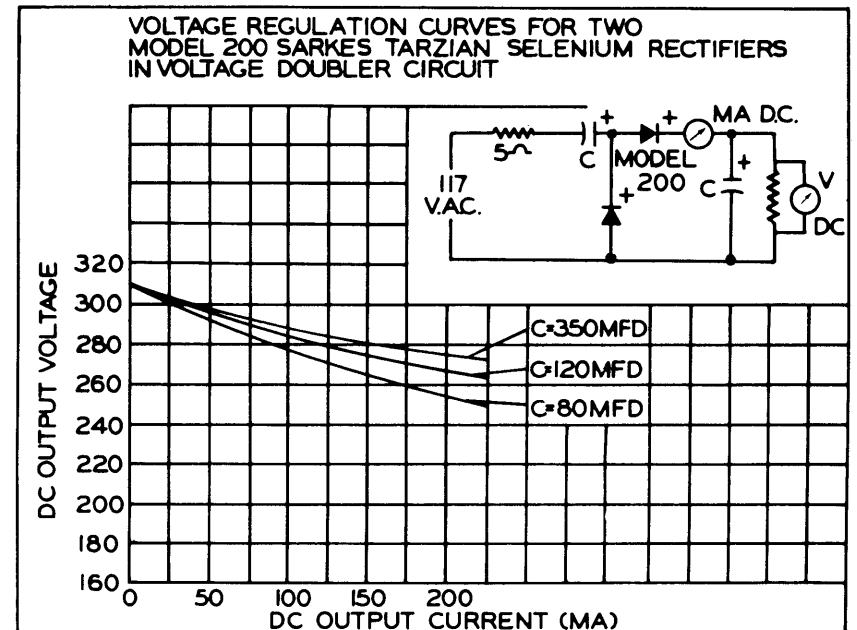



"Centre-Kooled" SELENIUM RECTIFIER Model 250

250 MA 130V Max.

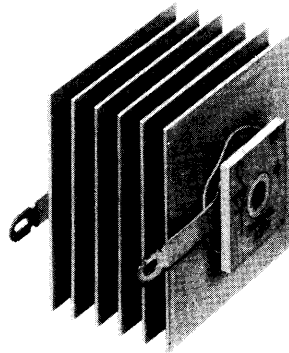

CHARACTERISTICS

Max. RMS Input Voltage.....	130	Approximate Rectifier Voltage Drop....	5
Max. Inverse Peak Voltage.....	380	Minimum Series Resistance (Ohms).....	5
Max. Peak Current (MA).....	2500	Max. Operating Plate Temperature	85°C
Max. RMS Current (MA).....	625		
Max. DC Current (MA).....	250		

DIMENSIONS IN INCHES

(See dimensional diagram, page 4)

A—13/32" B—1.6" C—1.6" D—1 5/16"

One of the most popular of the Sarkes Tarzian Center-Kooled Selenium Rectifiers

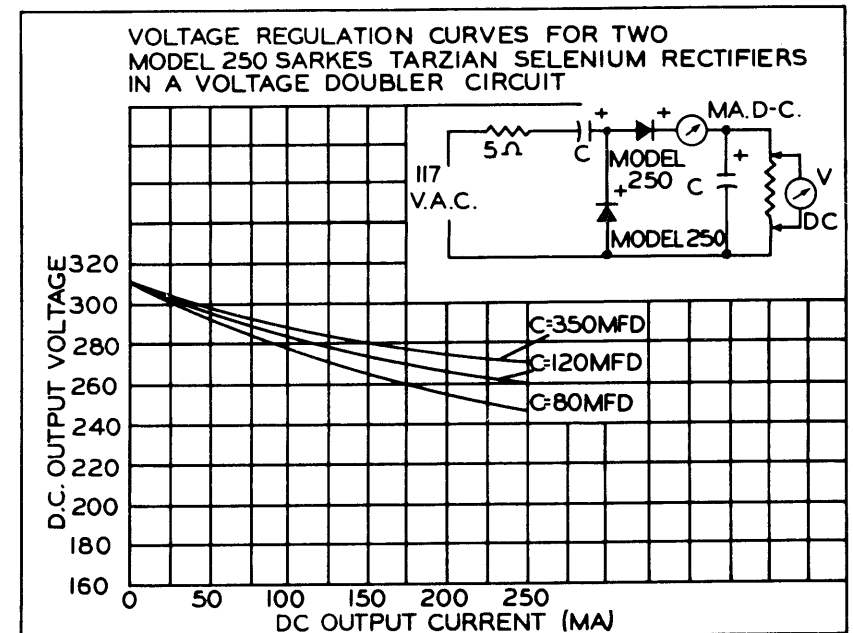
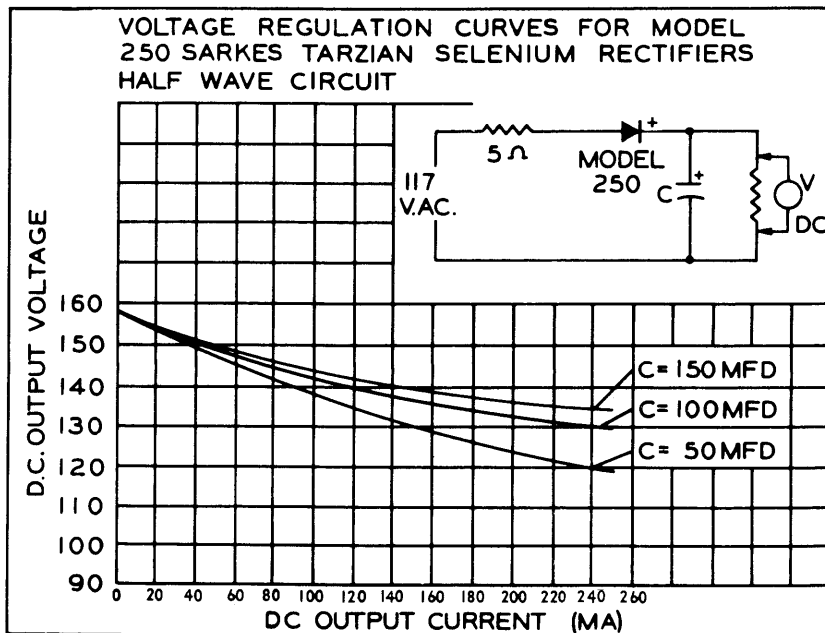

for television is the Model 250, designed for use in applications where more than 200 milliamperes is required.

The Model 250 Rectifier is particularly adaptable in the B+ power supply of 10 and 12 inch television receivers, although its relatively high voltage and current handling capacities make it popular in many electronic devices.

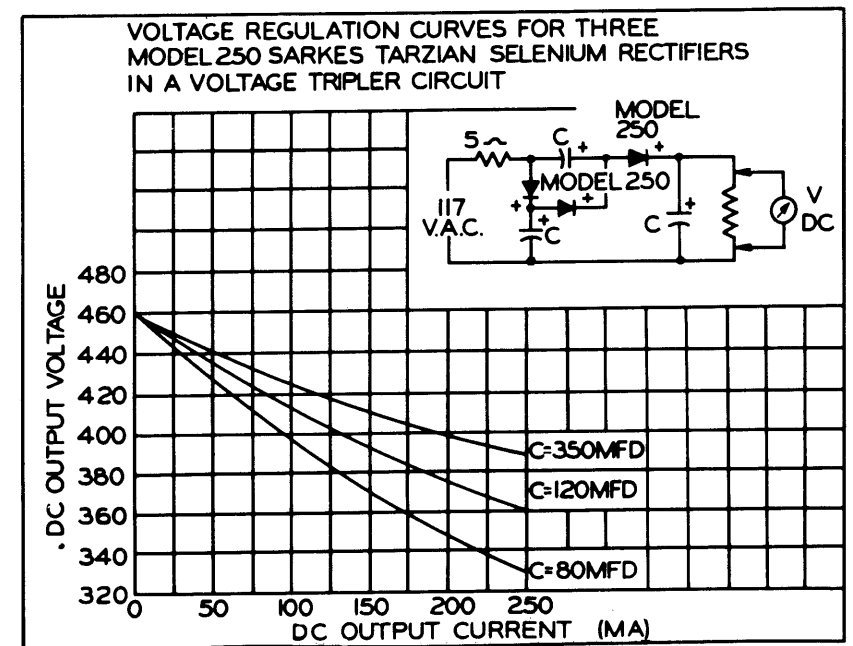

Sarkes Tarzian

"Centre-Cooled" SELENIUM RECTIFIER

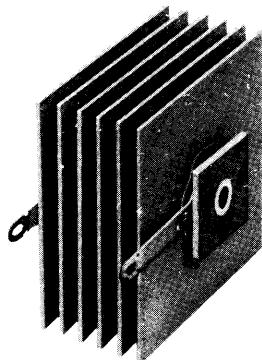

Model 350

350 MA 130V Max.

CHARACTERISTICS

Max. RMS Input Voltage.....	130	Max. DC Current (MA).....	350
Max. Inverse Peak Voltage.....	380	Approximate Rectifier Voltage Drop....	5
Max. Peak Current (MA).....	3500	Minimum Series Resistance (Ohms).....	5
Max. RMS Current (MA).....	875	Max. Operating Plate Temperature.....	85°C

DIMENSIONS IN INCHES

(See dimensional diagram, page 4)

A—13/32" B—2" C—2" D—1 5/16"

The steady increase in the size of television receivers has caused an increase in the power requirements from the B+ power supply. The Sarkes Tarzian Model 350

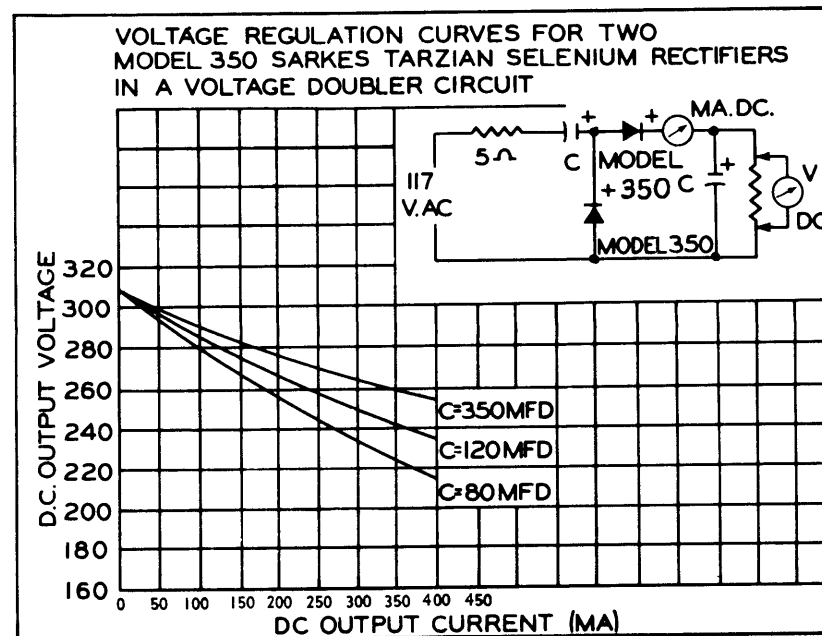
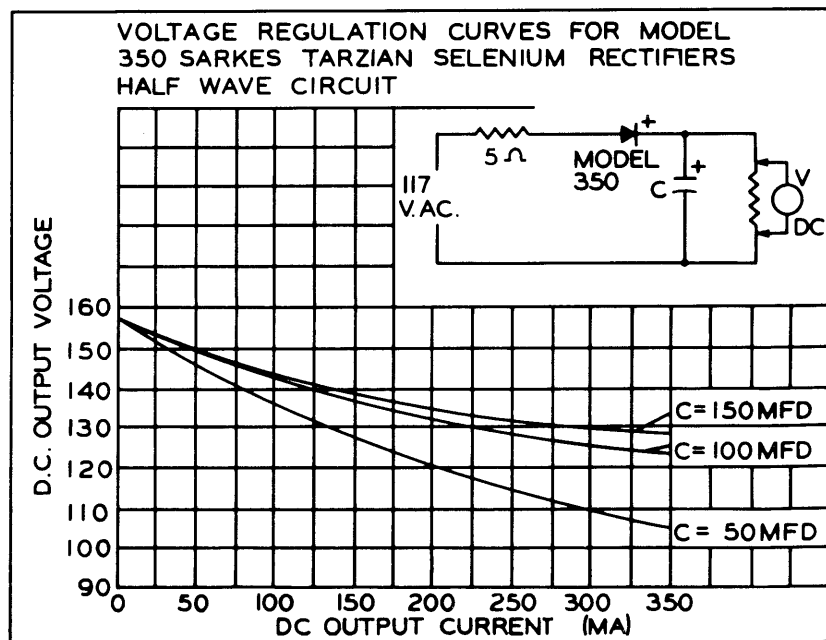

Selenium Rectifier is rated at 350 MA D. C. at a maximum input voltage of 130 volts A. C. By use of a simple half-wave circuit it is possible to power a small A. C.-D. C. or portable television receiver.

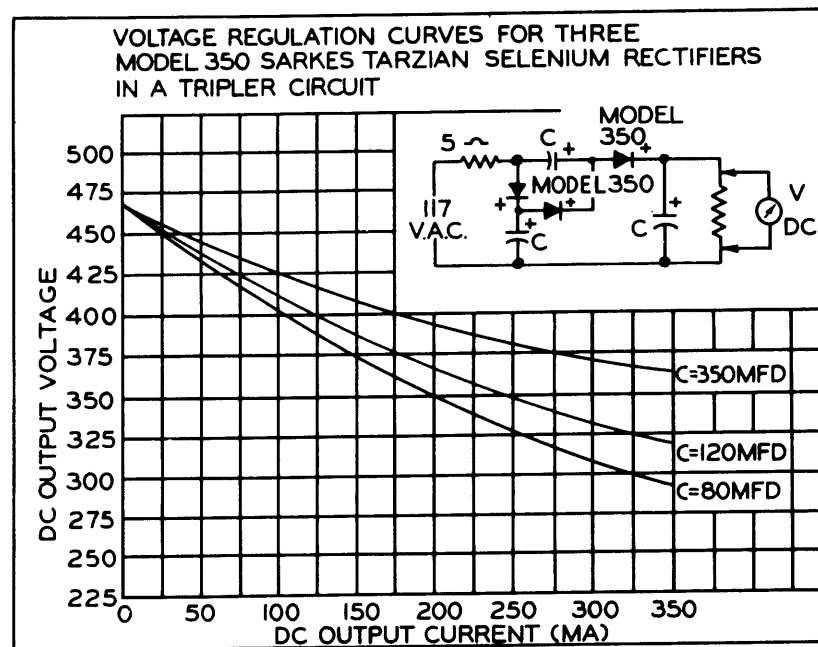

Sarkes Tarzian

"Centre-Kooled" SELENIUM RECTIFIER

Model 450

450 MA 130V Max.

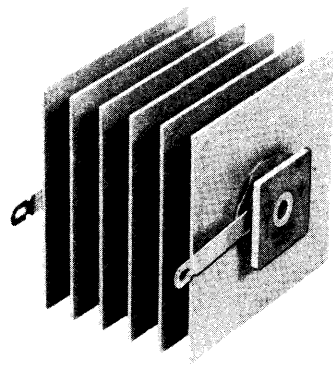

CHARACTERISTICS

Max. RMS Input Voltage.....	130	Max. DC Current (MA).....	450
Max. Inverse Peak Voltage.....	380	Approximate Rectifier Voltage Drop....	5
Max. Peak Current (MA).....	4500	Minimum Series Resistance (Ohms).....	5
Max. RMS Current (MA).....	1125	Max. Operating Plate Temperature.....	85°C

DIMENSIONS IN INCHES

(See dimensional diagram, page 4)

A—13/32" B—2" C—2" D—17/8"

The Model 450 is another Sarkes Tarzian Selenium Rectifier which has been designed for specific use in larger television receivers, although it has found wide ap-

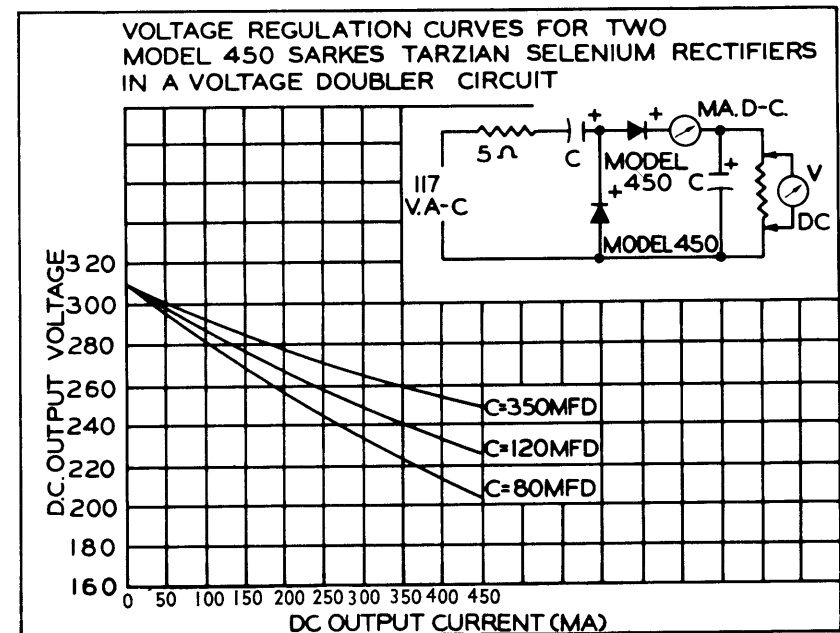
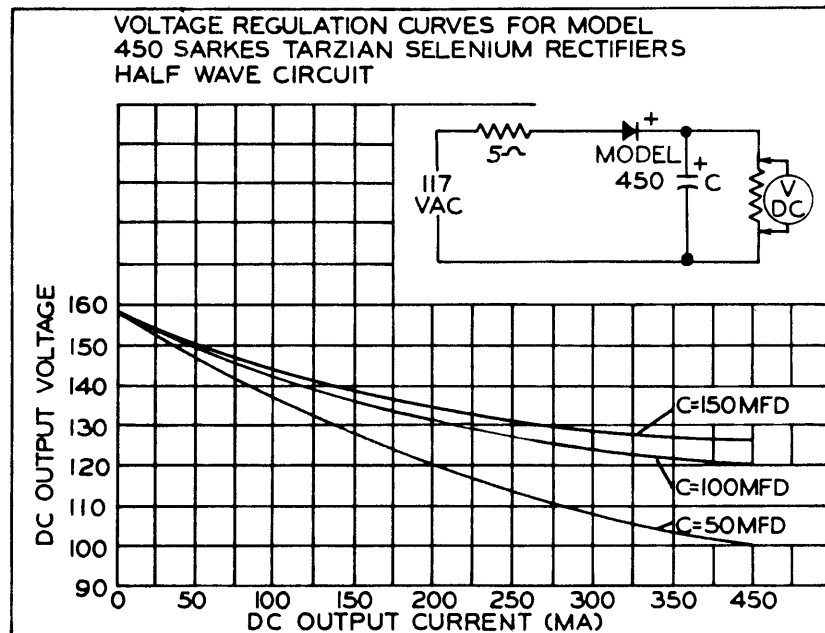

plication in many electronic devices requiring substantial D. C. power. The Model 450 is extremely popular with many large television manufacturers in their 16 and 19 inch sets, and currently has the largest available power output. However, as the television manufacturers requirements increase, future designs will be engineered and developed to meet the needs.

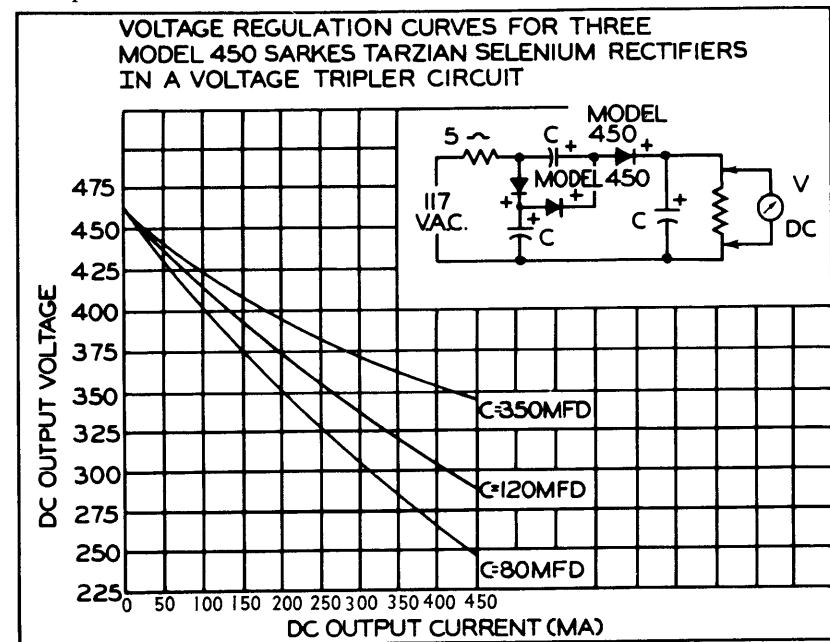

Sarkes Tarzian

"Centre-Kooled" SELENIUM RECTIFIER

Model 450

450 MA 130V Max.

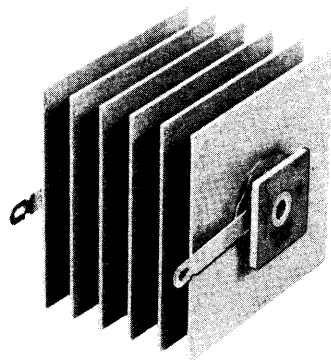

CHARACTERISTICS

Max. RMS Input Voltage.....	130	Max. DC Current (MA).....	450
Max. Inverse Peak Voltage.....	380	Approximate Rectifier Voltage Drop....	5
Max. Peak Current (MA).....	4500	Minimum Series Resistance (Ohms).....	5
Max. RMS Current (MA).....	1125	Max. Operating Plate Temperature.....	85°C

DIMENSIONS IN INCHES

(See dimensional diagram, page 4)

A—13/32" B—2" C—2" D—17/8"

The Model 450 is another Sarkes Tarzian Selenium Rectifier which has been designed for specific use in larger television receivers, although it has found wide ap-

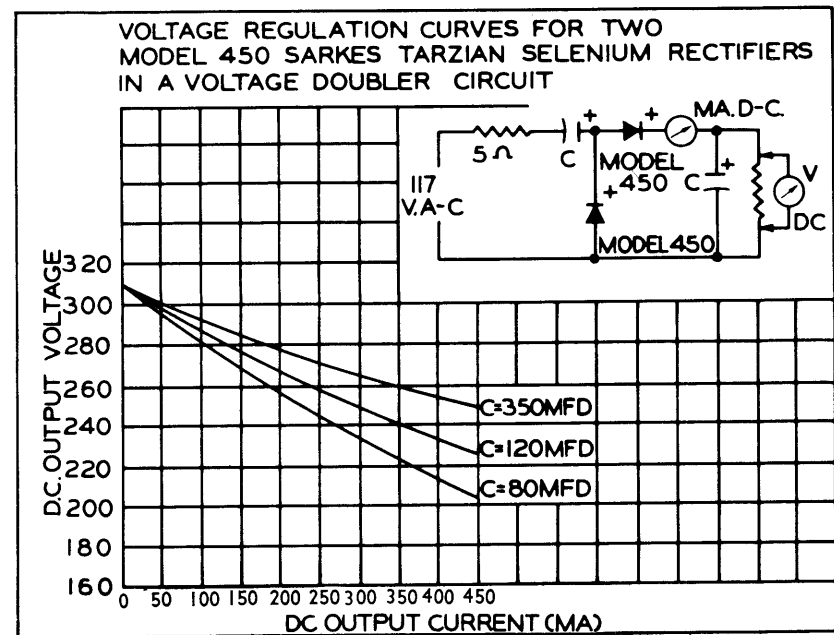
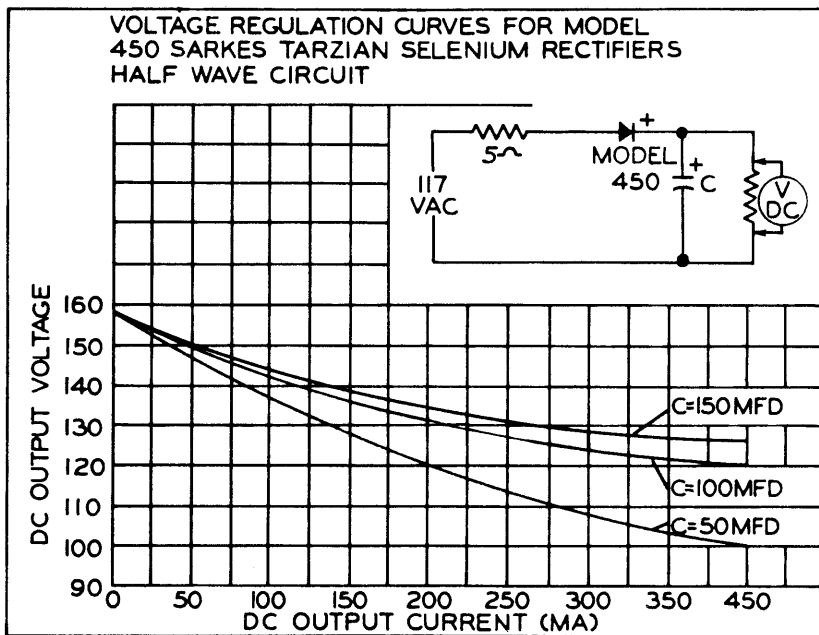

plication in many electronic devices requiring substantial D. C. power. The Model 450 is extremely popular with many large television manufacturers in their 16 and 19 inch sets, and currently has the largest available power output. However, as the television manufacturers requirements increase, future designs will be engineered and developed to meet the needs.

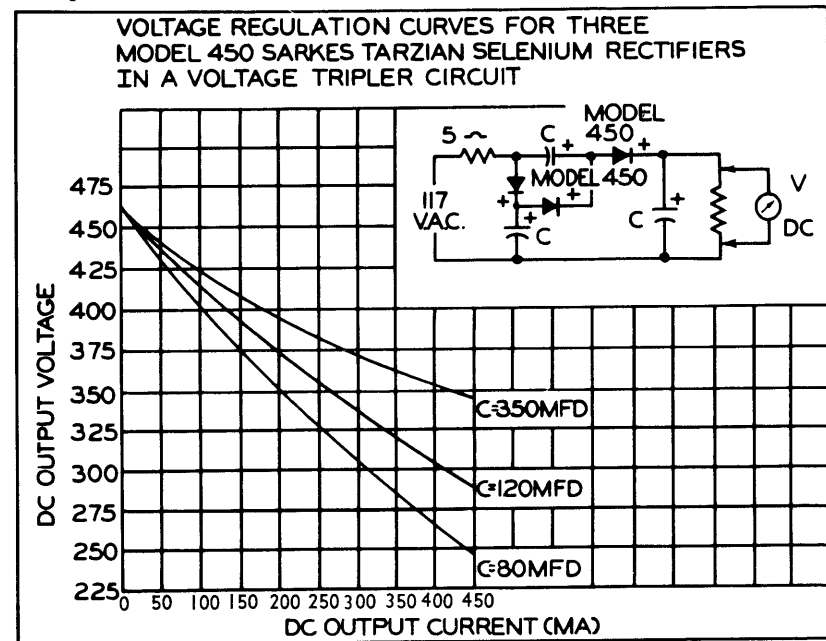

Sarkes Tarzian

"Centre-Kooled" SELENIUM RECTIFIER

Model 108

100 MA 160V Max.

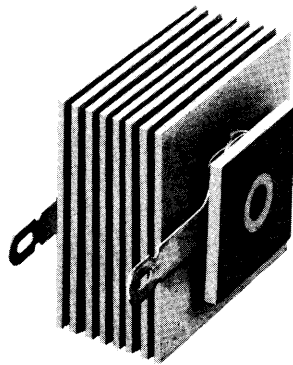

CHARACTERISTICS

Max. RMS Input Voltage.....	160	Approximate Rectifier Voltage Drop....	8
Max. Inverse Peak Voltage.....	440	Minimum Series Resistance (Ohms).....	22
Max. Peak Current (MA).....	1000	Max. Operating Plate	
Max. RMS Current (MA).....	250	Temperature	85°C
Max. DC Current (MA).....	100		

DIMENSIONS IN INCHES

(See dimensional diagram, page 4)

A—13/32" B—1.25" C—1.25" D—31/32"

The Sarkes Tarzian Model 108 Selenium Rectifier is designed for use in half-wave circuits having a power source in excess of 130 volts A. C. Rated at 160 volts A. C. and 100 MA D. C., this rectifier has found wide application in television receivers where it is used as one arm of a bridge circuit and in mobile equipment as part of a vibrator power supply.

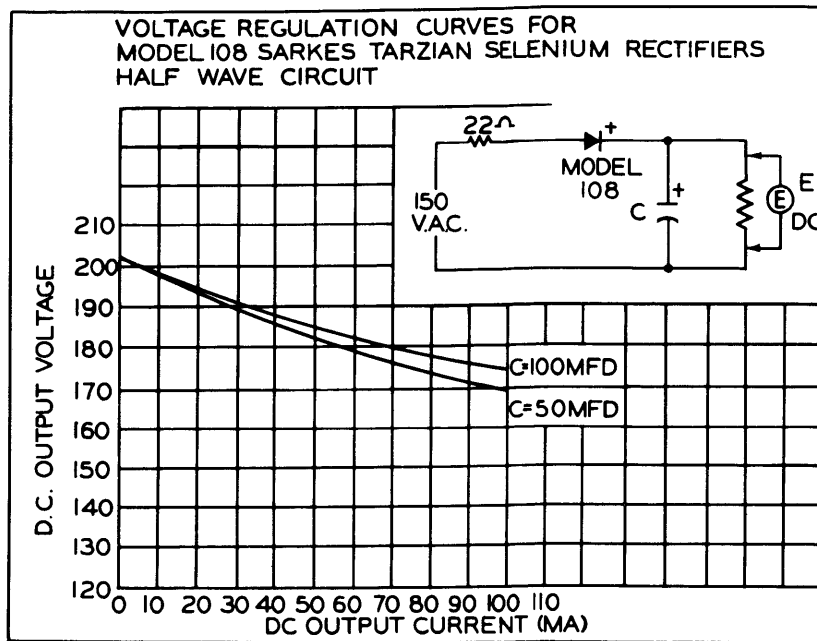

Sarkes Tarzian

"Centre-Kooled" SELENIUM RECTIFIER

Model 78D

75 MA 160V Max.

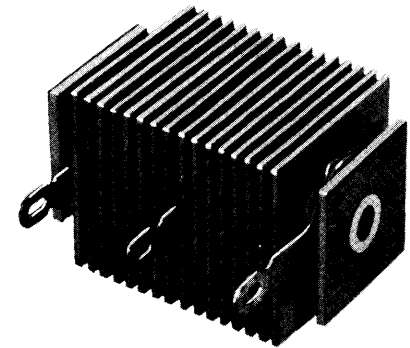

CHARACTERISTICS

Max. RMS Input Voltage.....	160	Approximate Rectifier Voltage Drop....	8
Max. Inverse Peak Voltage.....	440	Minimum Series Resistance (Ohms).....	22
Max. Peak Current (MA).....	750	Max. Operating Plate	
Max. RMS Current (MA).....	187	Temperature	85°C
Max. DC Current (MA).....	75		

DIMENSIONS IN INCHES

(See dimensional diagram, page 4)

A—13/32" B—1" C—1" D—15/8"

The Sarkes Tarzian Model 78D Selenium Rectifier is recommended for use in a voltage doubler circuit where the current requirements do not exceed 75 milliamperes D. C. It is also adaptable for use in a bridge circuit which will deliver 150 milliamperes. Two units are required for a bridge rectifier.

Typical characteristic curves follow.

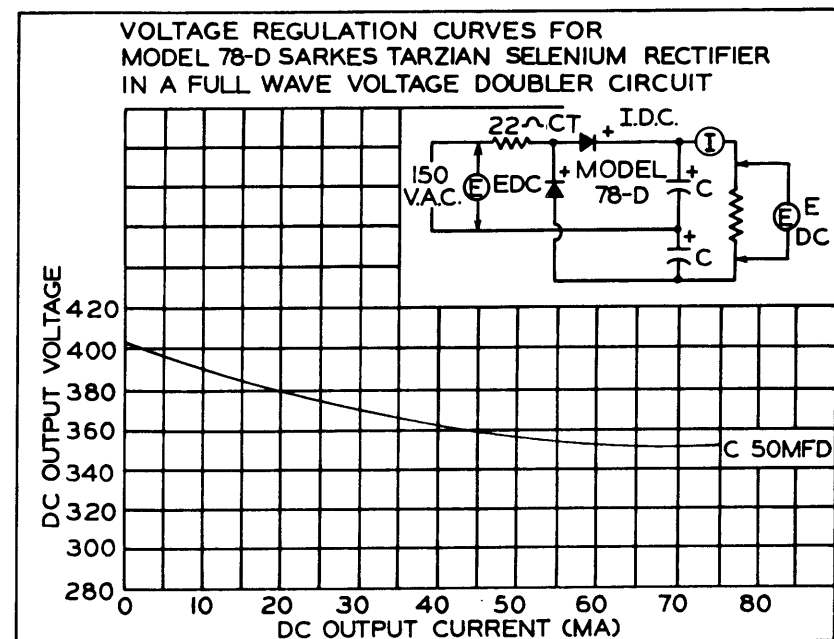

**Sarkes
Tarzian**

**"Centre-Kooled"
SELENIUM RECTIFIER**

Model 108D

100 MA 160V Max.

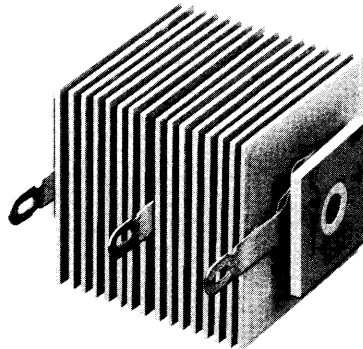

CHARACTERISTICS

Max. RMS Input Voltage.....	160	Approximate Rectifier Voltage Drop....	8
Max. Inverse Peak Voltage.....	440	Minimum Series Resistance (Ohms).....	22
Max. Peak Current (MA).....	1000	Max. Operating Plate	
Max. RMS Current (MA).....	250	Temperature	85°C
Max. DC Current (MA).....	100		

DIMENSIONS IN INCHES

(See dimensional diagram, page 4)

A—13/32" B—1.25" C—1.25" D—1 5/8"

Similar to Model 78D the Sarkes Tarzian Model 108D is recommended for use in applications which require more than 75 milliamperes D. C. in a voltage doubler circuit or 150 milliamperes in a bridge circuit. Rated at 160 volts A. C. and 100 milliamperes the Model 108D is used in vibrator power supplies and television receivers.

Typical characteristic curves follow.

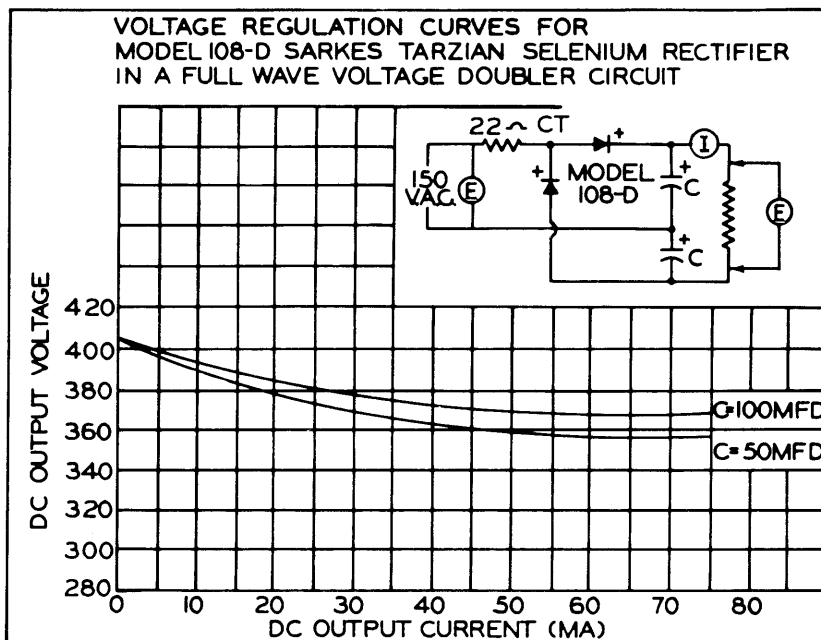

**Sarkes
Tarzian**

**"Centre-Kooled"
SELENIUM RECTIFIER**

Model 208D

200 MA 160V Max.

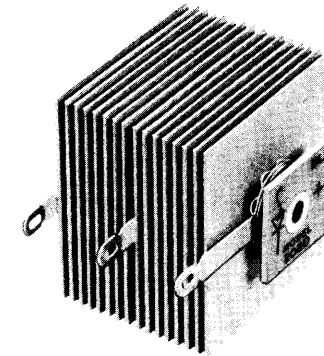

CHARACTERISTICS

Max. RMS Input Voltage.....	160	Approximate Rectifier Voltage Drop....	8
Max. Inverse Peak Voltage.....	440	Minimum Series Resistance (Ohms).....	22
Max. Peak Current (MA).....	2000	Max. Operating Plate	
Max. RMS Current (MA).....	500	Temperature	85°C
Max. DC Current (MA).....	200		

DIMENSIONS IN INCHES

(See dimensional diagram, page 4)

A—13/32" B—1.6" C—1.6" D—1 5/8"

Rated at 160 volts A. C. and 200 milliamperes D. C., when used as a voltage doubler, the Sarkes Tarzian Model 208D has been used in communications equipment, television receivers and electronic devices. The relatively high power rating and overload factors of this rectifier have made it ideal for use in application where dependability and ruggedness are essential qualities.

Typical characteristic curves follow.

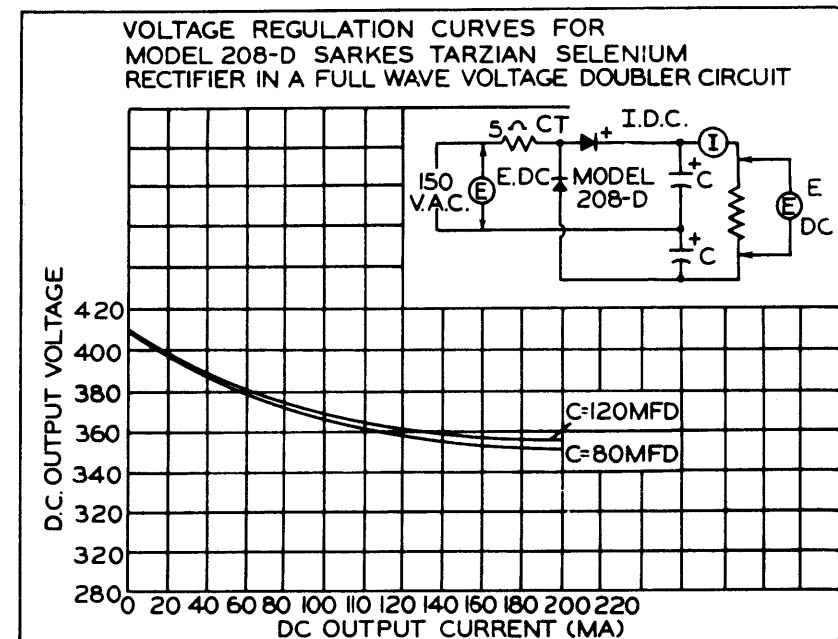

Other characteristic curves appear on page 41



**"Centre-Cooled"
BRIDGE TYPE
SELENIUM RECTIFIER**

The Sarkes Tarzian 154B rated at 25 volts A. C. and 150 milliamperes D. C., the 304B rated at 25 volts A. C. and 300 milliamperes D. C. and the 604B rated at 25 volts A. C. and 600 milliamperes D. C., have been found ideal for use in supplying D. C. Power for low voltage relays and tube filaments. The 120 cycle ripple frequency lends itself to good filtering which eliminates relay chatter and objectionable hum.

Model 154B
150 MA 25V Max.

CHARACTERISTICS

Max. RMS Input Voltage.....	25
Max. Inverse Peak Voltage.....	35
Max. Peak Current (MA).....	1800
Max. RMS Current (MA).....	270
Max. DC Current (MA).....	150
Approximate Rectifier Voltage Drop....	2

DIMENSIONS IN INCHES
(See dimensional diagram, page 4)
A—13/32" B—1"
C—1" D—11/16"

Model 304B
300 MA 25V Max.

CHARACTERISTICS

Max. RMS Input Voltage.....	25
Max. Inverse Peak Voltage.....	35
Max. Peak Current (MA).....	2400
Max. RMS Current (MA).....	540
Max. DC Current (MA).....	300
Approximate Rectifier Voltage Drop....	2

DIMENSIONS IN INCHES
(See dimensional diagram, page 4)
A—13/32" B—1.25"
C—1.25" D—11/16"

Model 604B
600 MA 25V Max.

CHARACTERISTICS

Max. RMS Input Voltage.....	25	Max. RMS Current (MA).....	1080
Max. Inverse Peak Voltage.....	35	Max. DC Current (MA).....	600
Max. Peak Current (MA).....	4000	Approximate Rectifier Voltage Drop....	2

DIMENSIONS IN INCHES
(See dimensional diagram, page 4)
A—13/32" B—1.6" C—1.6" D—11/16"

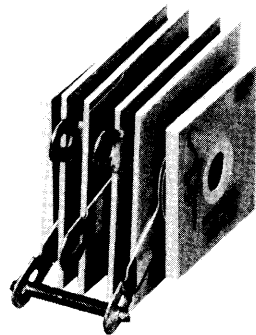

Model 154B

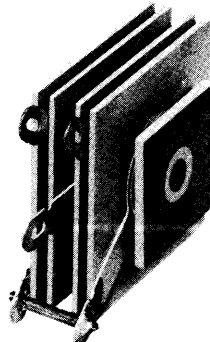

Model 304B

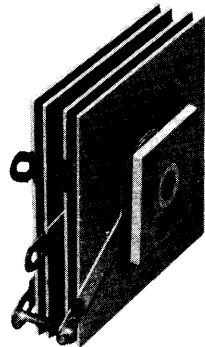

Model 604B

Applications

The versatile Selenium Rectifier has found wide application in all types of electrical and electronic equipment including radio and television receivers.

The circuit suggestions on succeeding pages are offered as guides and ideas for the engineer and technician. Many thousands of applications, ranging from simple half wave to multiple stage circuits, are possible. Design this efficient and reliable unit into your set or equipment and, if necessary, call on us for assistance. Remember, Sarkes Tarzian engineers stand ready to assist you on any conversion problem at no obligation to you.

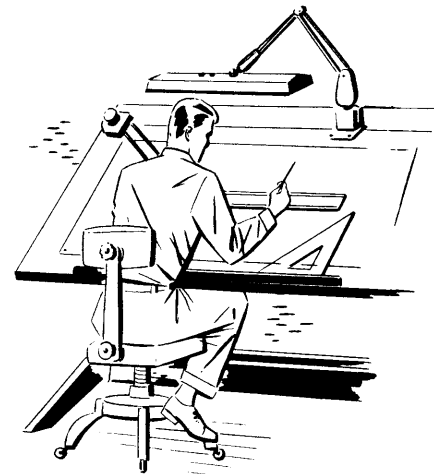

Home Receivers

The selenium rectifier has been widely accepted by leading radio manufacturers as a standard component in all types of portable, table model, console, phonograph and combination radio-phonograph sets. A few of the features that have made the selenium rectifier popular are—reduced internal heat, because of elimination of the filament, increased sensitivity in the set, because of more power output realized by increased output voltage from the B+ power supply and in portable radios, the instant starting feature because the rectifier requires no “warm-up” time.

On succeeding pages appear a few of the many typical applications of the selenium rectifier in home receivers.

Home Receivers

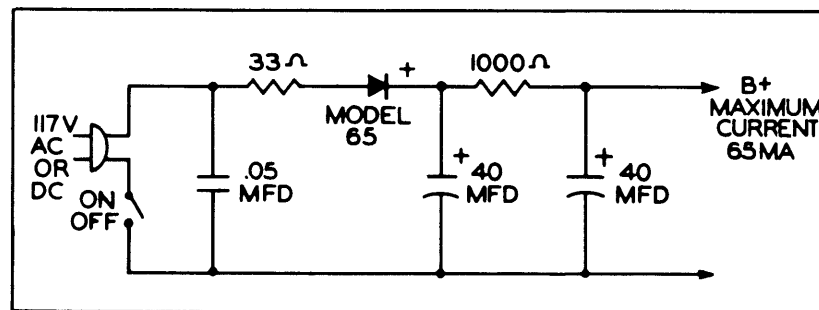

LOW CURRENT B+ POWER SUPPLY

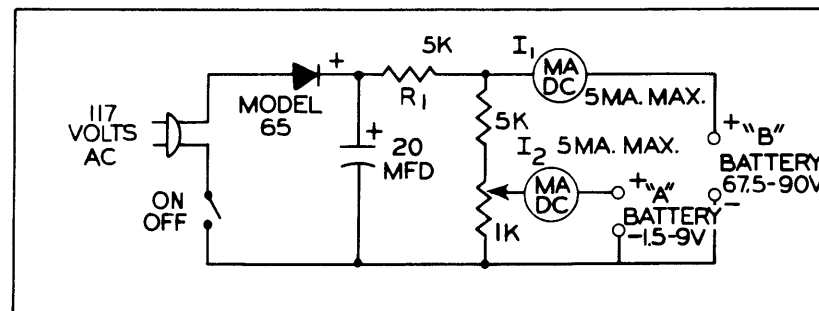

BATTERY CHARGER FOR PORTABLE DRY CELL BATTERIES

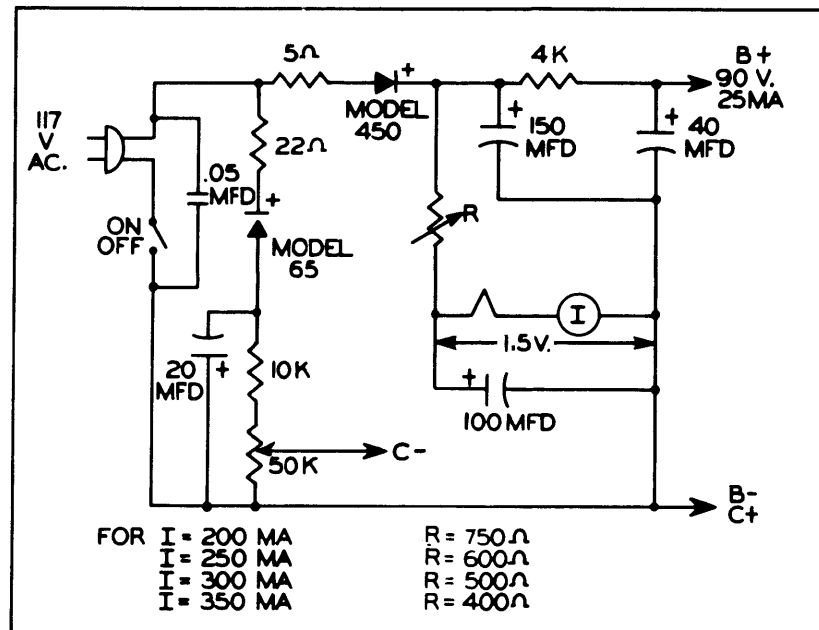

B+ BIAS AND FILAMENT SUPPLY FOR FARM RADIOS

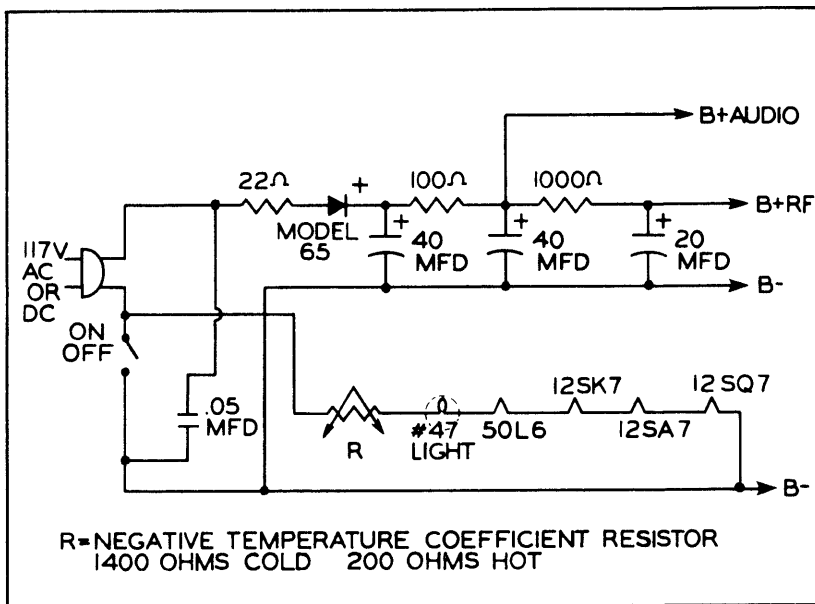

AC-DC B+ POWER SUPPLY USING THE SARKES TARZIAN MODEL 65 SELENIUM RECTIFIER IN CONJUNCTION WITH AN N. T. C. RESISTOR

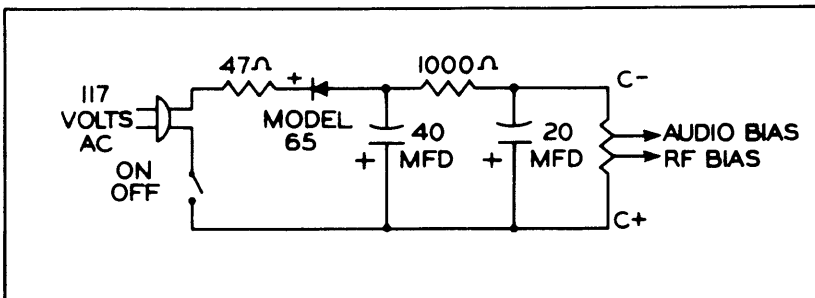

BIAS POWER SUPPLY

Home Receivers

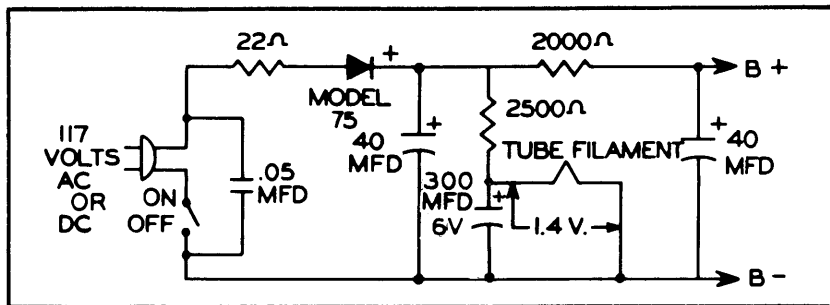

THREE WAY PORTABLE B+ POWER SUPPLY

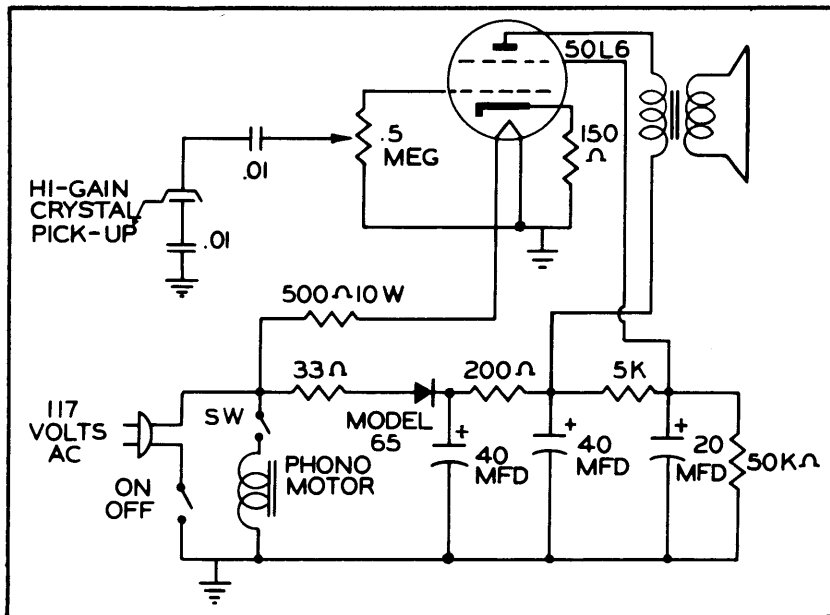

PHONOGRAPH AMPLIFIER

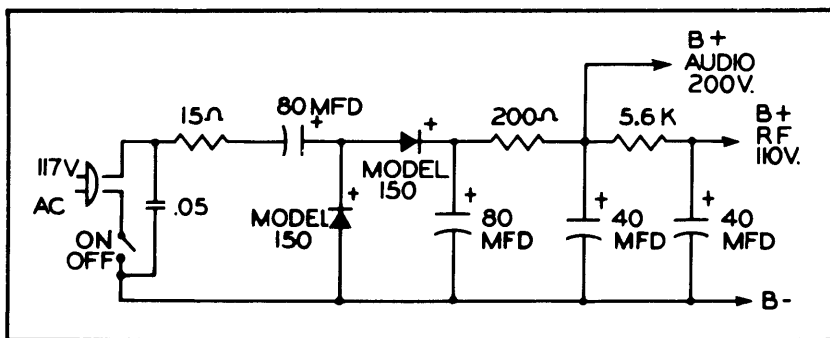

B+ POWER SUPPLY FOR CONSOLE RADIO

Television

The impact of television on American economy has been great. The popularity and wide distribution of television is a tribute to the progressive design engineers who have spared no effort to decrease the cost of television receivers and make them available to consumers in all income groups. These same progressive engineers have realized the advantages of selenium rectifiers and are including them as a standard component in many of the sets they design. This is not surprising when the advantages of small size, light weight, low cost, high efficiency, flexibility of design, and high overload factors are realized.

On succeeding pages appear a few typical circuits now being used in television receivers. These are representative of typical designs and do not by any means include all that are in popular use. The engineer and technician can use these as a basis for improved designs in his application.

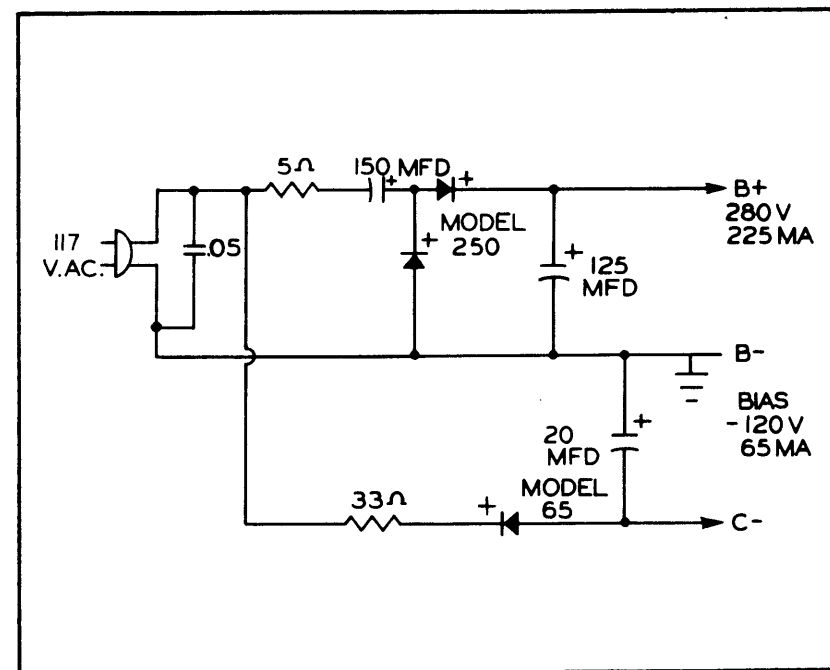

TYPICAL VOLTAGE DOUBLER WITH BIAS SUPPLY

Television

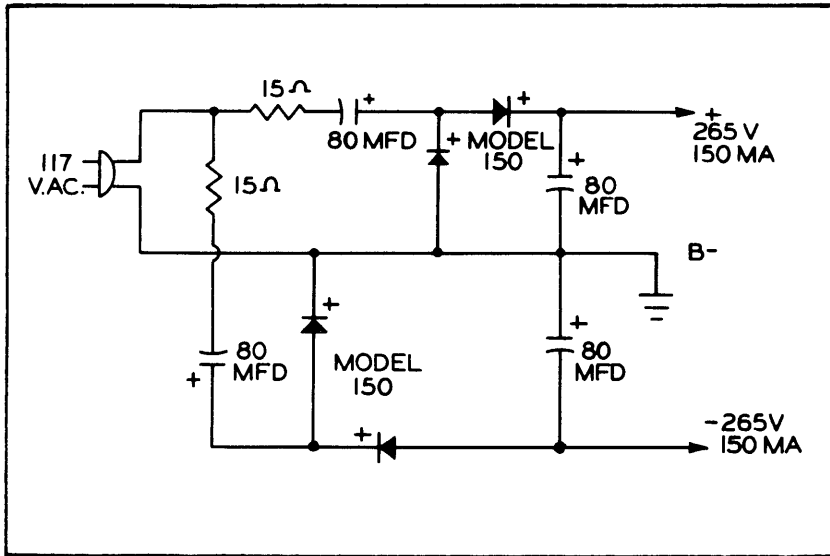

DUAL VOLTAGE DOUBLER WITH COMMON B-

Television

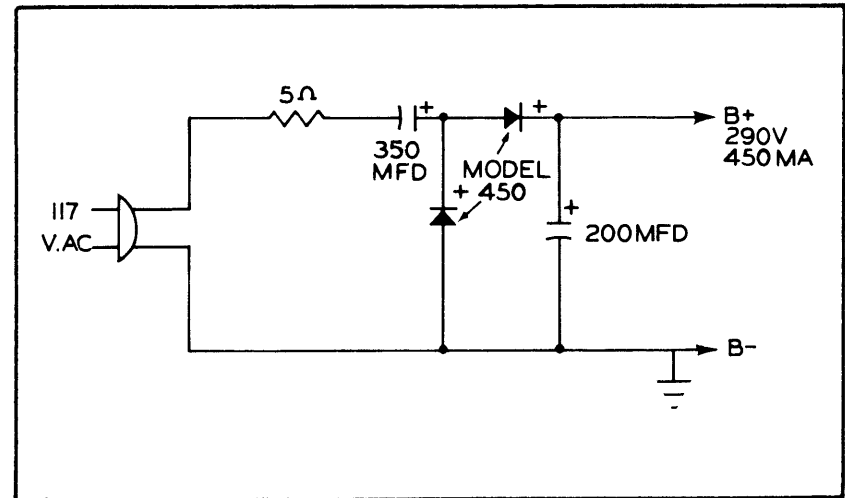

TYPICAL VOLTAGE DOUBLER

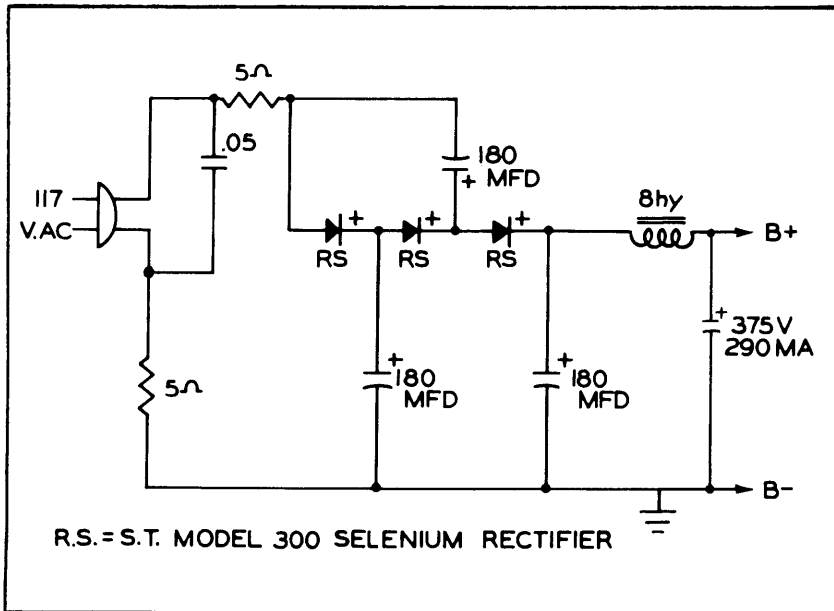

TYPICAL VOLTAGE TRIPLER

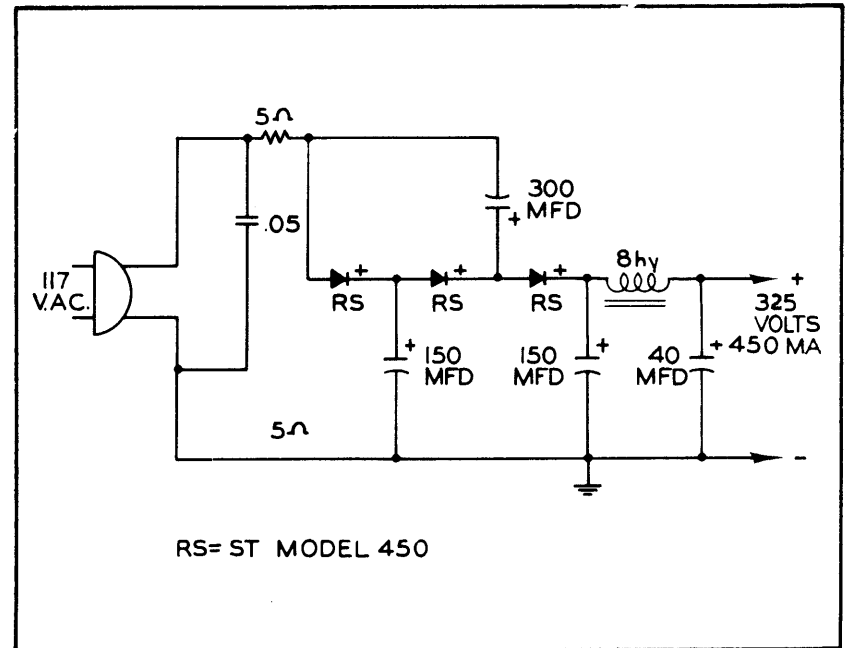

POWER SUPPLY FOR LARGE TELEVISION RECEIVERS

Television

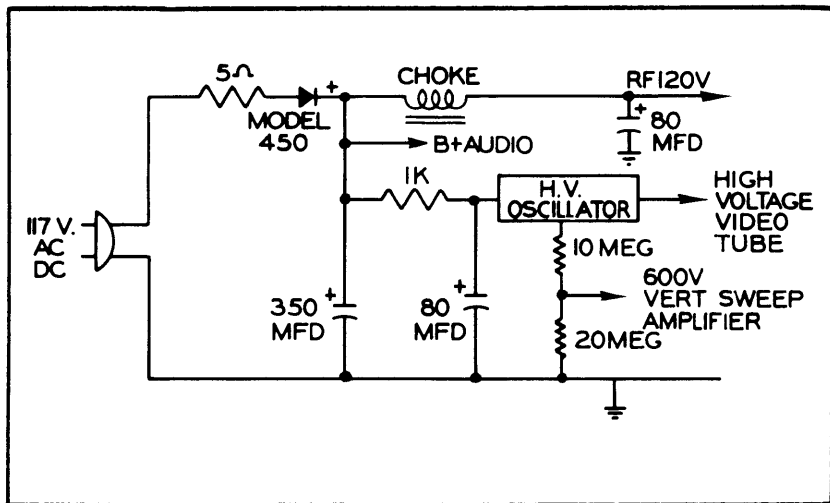

AC DC AND PORTABLE TELEVISION POWER SUPPLY

Television

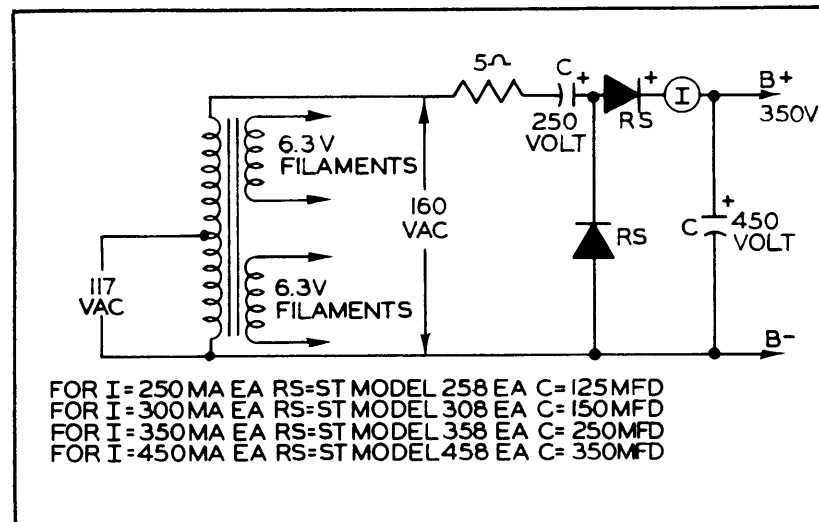

B+ POWER SUPPLY FOR TELEVISION RECEIVERS

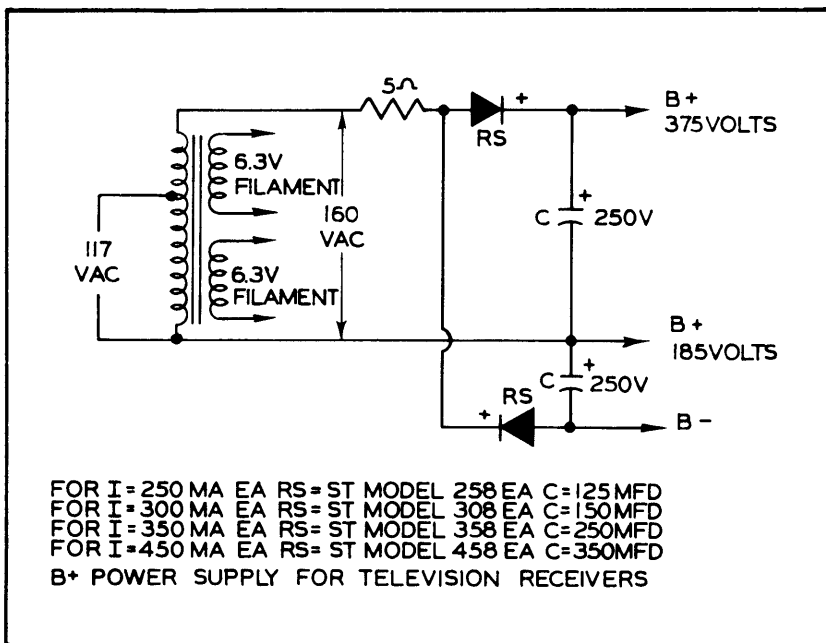

B+ POWER SUPPLY FOR TELEVISION RECEIVERS

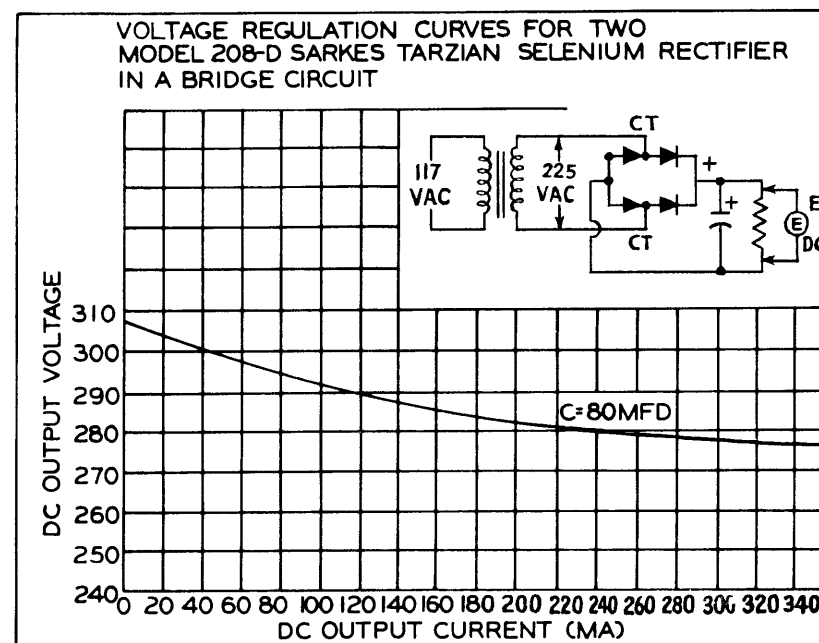

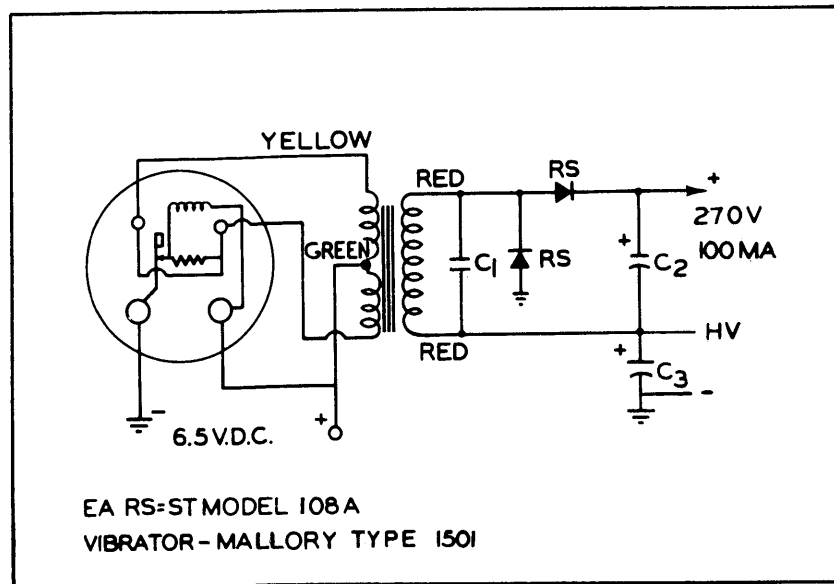

TYPICAL AUTO RADIO POWER SUPPLY

C₁: SECONDARY BUFFER CONDENSER .1 MFD. 600 V A.C. RATING

C₂: 40 MFD. 450 V ELECTROLYTIC CONDENSER (Separate Section)

C₃: 40 MFD. 450 V ELECTROLYTIC CONDENSER (Separate Section)

TRANSFORMER DESIGN

Core: 1 1/8" stack EI-12 (Allegheny) 1" center leg laminations punched from No. 24 gauge dynamo grade iron annealed after punching interleave 2 x 2.

Primary: Wound outside 50 T No. 15 en. wire CT.

Secondary: Wound next to core 680 T No. 31 en. wire.

Input: 6.5 volts Output: 270V @ 100 ma. D.C.

Exciting Current: With 8.0 volts A. C. 60 cycle sine wave impressed across the entire primary the exciting current shall not be less than .400 or more than .600 amps. Average .500 amps.

Miscellaneous

Although the popular Centre-Kooled selenium rectifiers were originally designed for use in radio and television receivers, many engineers in all phases of electronics have taken advantage of these versatile, low cost units in special types of Electronic Equipment.

A few typical applications are indicated on following pages. These illustrate the wide use of the selenium rectifier in sets where a DC potential is either required or desirable.

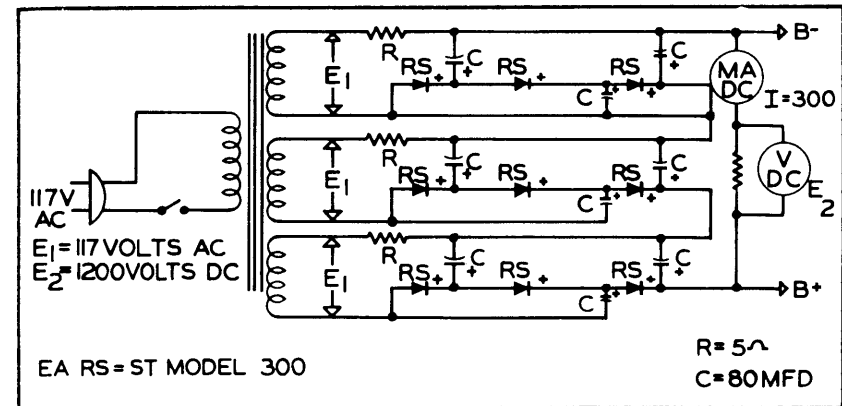

HIGH VOLTAGE POWER SUPPLY FOR TRANSMITTERS

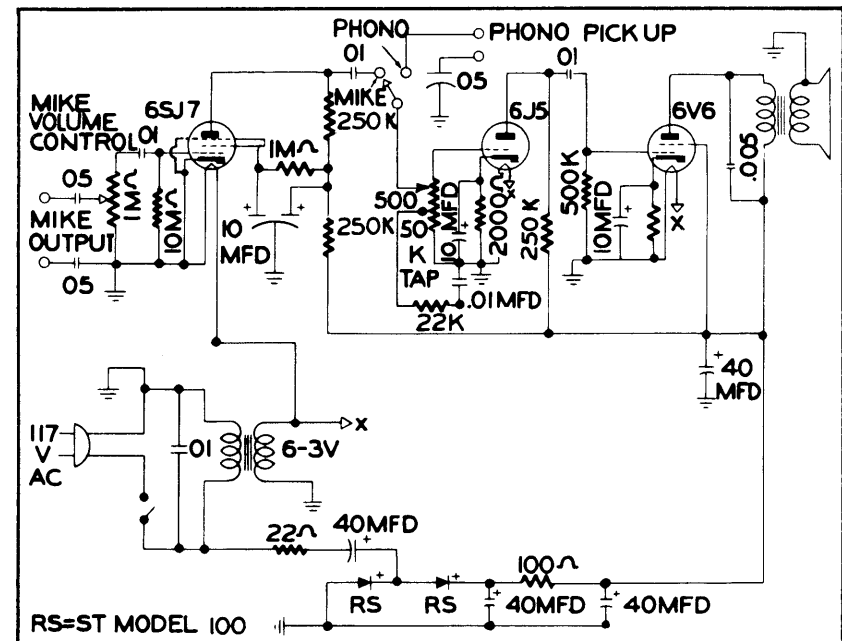

AUDIO AMPLIFIER

Selenium Rectifier Tester

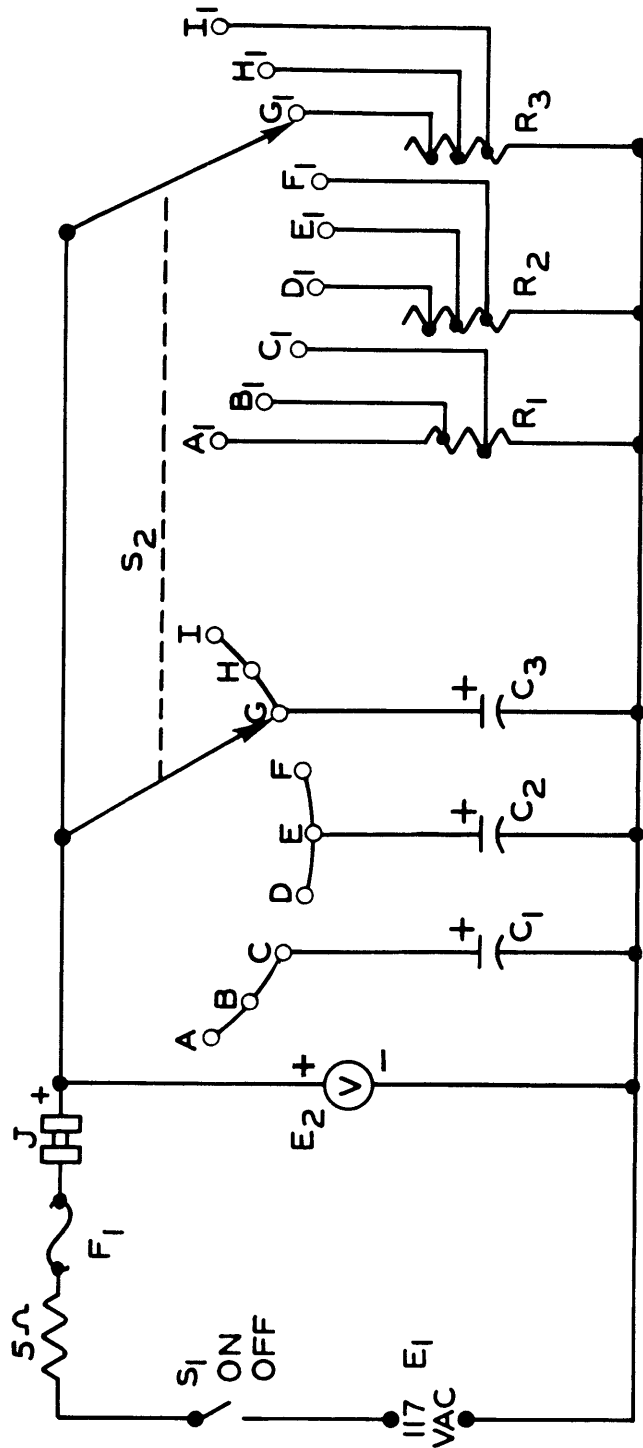

Parts List

SELENIUM RECTIFIER TESTER

- F₁—Fuse—2 ampere
- J₁—Jack, to accept rectifier lugs
- S₁—Switch—Toggle—On-Off
- S₂—Switch—2 wafer, non shorting
- E₂—Voltmeter—0-150 Volts D. C.
- C₁—Capacitor—50 mfd.—150 volt
- C₂—Capacitor—125 mfd.—150 Volt
- C₃—Capacitor—350 mfd.—150 Volt
- R₁—Resistor—Adjustable—2000 ohms—25 watt—Tapped at 2000; 1750 and 1300 ohms
- R₂—Resistor—Adjustable—1000 ohms—50 watt—Tapped at 850; 650 and 520 ohms.
- R₃—Resistor—Adjustable—500 ohms—100 watt—Tapped at 430; 375 and 290 ohms

Selector Switch Positions

- A-A₁ Model 65—2000 ohms on R₁
- B-B₁ Model 75—1750 ohms on R₁
- C-C₁ Model 100—1300 ohms on R₁
- D-D₁ Model 150—850 ohms on R₂
- E-E₁ Model 200—650 ohms on R₂
- F-F₁ Model 250—520 ohms on R₂
- G-G₁ Model 300—430 ohms on R₃
- H-H₁ Model 350—375 ohms on R₃
- I-I₁ Model 450—290 ohms on R₃

Operating Instructions

SELENIUM RECTIFIER TESTER

1. With switch S₁ in the off position, plug rectifier to be tested into the socket. Observe polarity very carefully.
2. Rotate Selector Switch S₂ to proper position for rectifier type being tested.
3. Apply voltage by pushing switch S₁ to the on position.
4. Within 5 minutes from the time the voltage is applied the readings should be as follows:

MODEL	APPROX. DC VOLTAGE READING
65.....	130 volts
75.....	130 volts
100.....	125 volts
150.....	130 volts
200.....	130 volts
250.....	130 volts
300.....	125 volts
350.....	125 volts
450.....	120 volts

5. Reject all units that do not approximate these voltages.

CAUTION: It is important that rectifier polarity is closely observed.

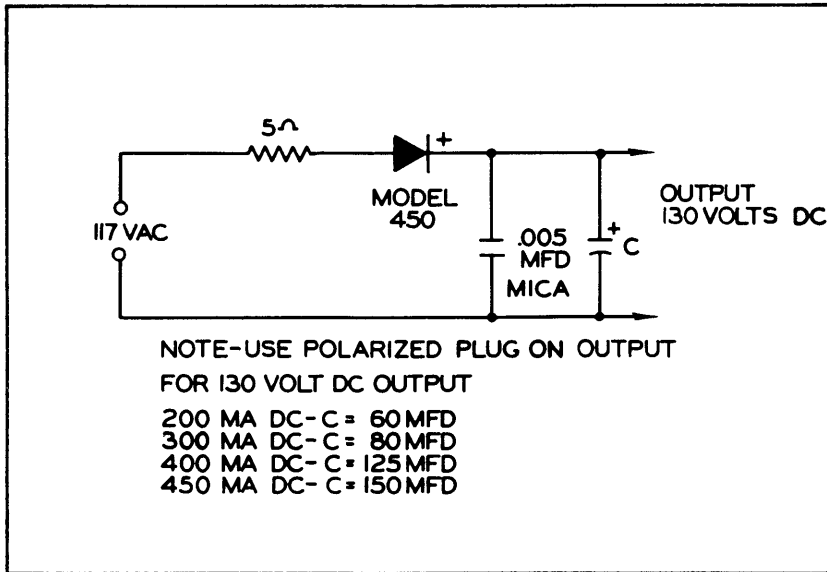

LOW COST LABORATORY DC POWER SUPPLY

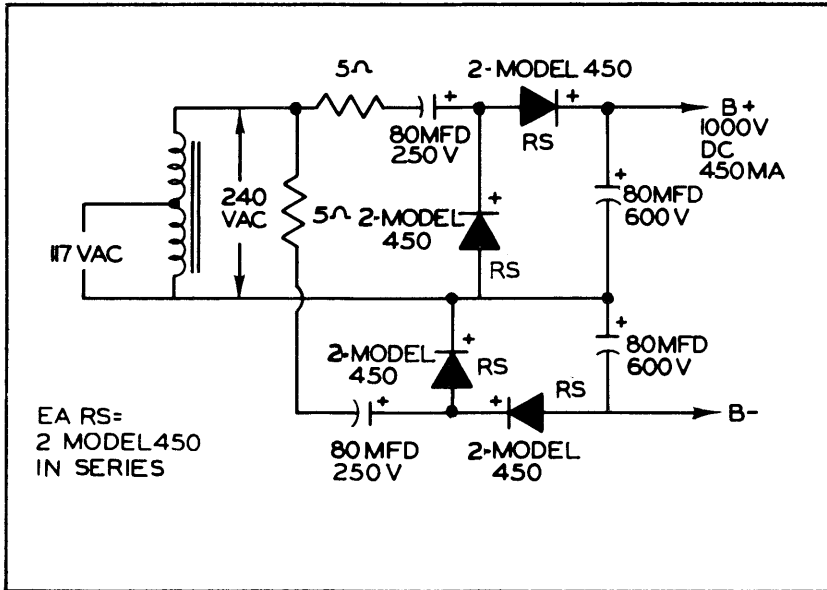

TRANSMITTER POWER SUPPLY

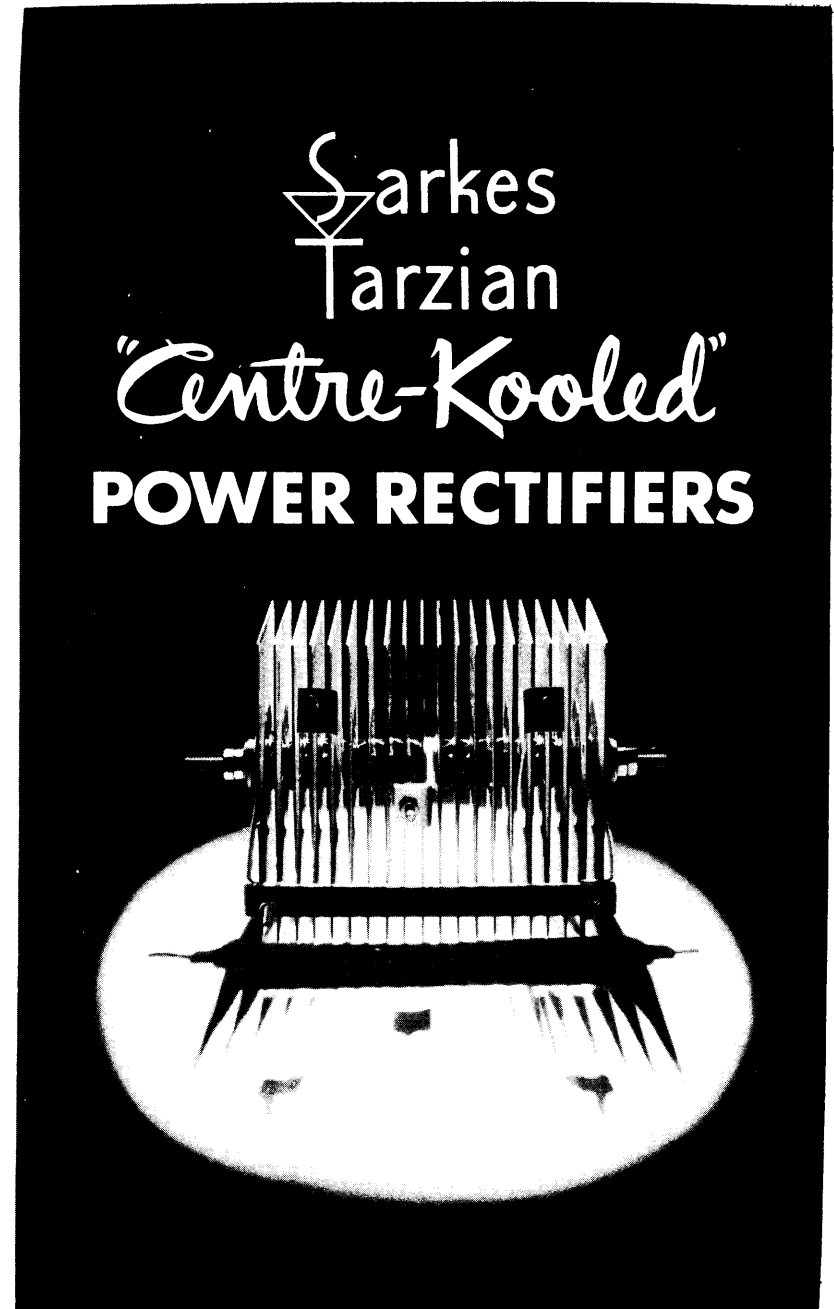

THE SELENIUM RECTIFIER

The fields of application of selenium rectifiers have steadily expanded and today the selenium rectifier is accepted by industry as an efficient and economical means of converting alternating current to direct current. Over a period of years, selenium rectifiers have proved their characteristics of long life, dependability and maintenance free operation under severe operating conditions.

Basically, the selenium rectifier consists of a nickel plated aluminum base plate coated with selenium over which a low temperature alloy is sprayed. The aluminum base plate serves as the negative electrode and the alloy as the positive, with current flowing readily from the base plate to the alloy but encountering high resistance in the opposite direction. This phenomena results in effective rectification of an alternating input voltage and current with the efficiency of conversion dependent to some extent of the ratio of the resistance in the conducting direction to that of the blocking direction. In normal power applications a ratio of 100 to 1 is satisfactory; however, special applications, such as magnetic amplifiers, often require ratios in the order 1000 to 1.

The basic selenium rectifier cell is actually a diode capable of half wave rectification; however, since many applications require full wave direct current for maximum efficiency and minimum ripple, a plurality of cells in series, parallel, or series-parallel combinations are stacked in an assembly. Since practically an unlimited number of combinations are possible with available cell sizes, most applications are considered individually and suitable selenium rectifier stacks, custom designed for the specific application, are recommended by the manufacturer.

Selenium rectifiers are operated over a wide range of voltages and currents and are adaptable to a wide range of physical requirements. Selenium rectifiers will operate at high efficiency over a temperature range of -55° centigrade to 100° centigrade, and when suitably finished can withstand long period exposures to salt and humid atmospheres. Typical applications range from a few volts at milliamperes of current to thousands of amperes at relatively high voltages. For instance, it is practical to use selenium rectifiers in a cyclotron application which may require 50,000 volts at 5 milliamperes or in electroplating and electrolysis equipments which require up to 100,000 am-

peres with voltages in the order of 50 volts D.C. Regardless of power, voltage, or current requirements, wherever direct current is either necessary or desirable, selenium rectifiers will deliver direct current power both economically and efficiently. On following pages a few typical rectifier designs are tabulated to serve as a guide to engineers. These represent only a few of the many possible and practical designs; therefore, if the rectifier to meet your requirement is not listed a letter or phone call will result in an immediate recommendation.

Efficiency

The efficiency of Sarkes Tarzian rectifiers is high, usually in the order of 90% in three phase bridge circuits and 70% in single phase bridge circuits. Of particular interest is the very slight decrease in efficiency even at high current overloads; Figure 1 shows a decrease of only 10% in the efficiency of a three phase bridge circuit as the load current is increased to 300% of normal rated values; in the single phase bridge the decrease is only 5% under the same conditions. These data are pertinent to engineers who anticipate forced air cooling and large current overload factors in their equipment. The efficiency curves shown in Figure 1 are for normal operating conditions, at low temperatures the efficiency will decrease somewhat.

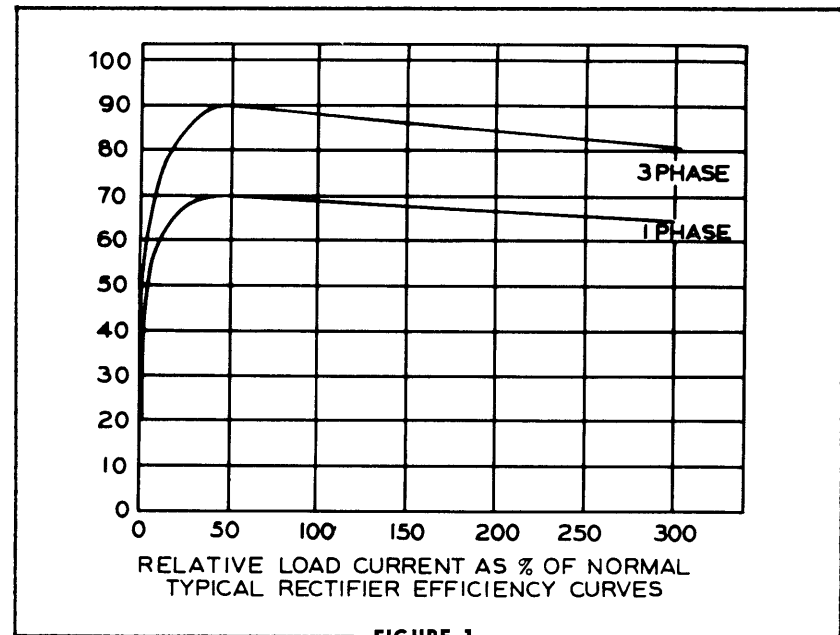

FIGURE 1

Aging

Under operating conditions, and, to a lesser extent, when idle, the selenium rectifier will age. During the aging period the forward and reverse resistances will increase gradually, and, after approximately one year, stabilize. This aging will result in approximately a 7% decrease in output voltage, therefore, in extremely critical applications, aging taps should be provided on the transformer to compensate for the increase in the rectifier resistance. Sarkes Tarzian power type rectifiers will last indefinitely when properly installed and operated within recommended ratings.

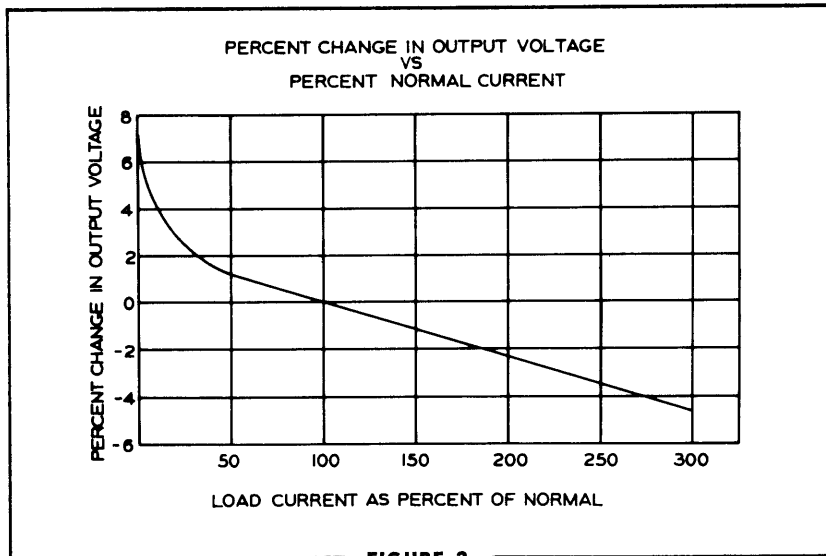

FIGURE 2

Voltage Regulation

The selenium rectifier has extremely low internal impedance which exhibits non-linear characteristics with respect to applied voltage. This results in very good voltage regulation even at large multiples of normal current. Figure 2 shows that as the load is varied from 0 to 300% of normal, the output voltage will change approximately 10%. It should be noted that because of non-linear characteristics, the voltage drop increases rapidly below 50% of normal load, and should be taken into consideration in applications requiring very small load currents. The curve in figure 2 applies to single phase full wave bridge, and center tap circuits which utilize both halves of the input wave shape. In single phase half wave circuits the regulation will be poorer; in three phase circuits the regulation will be better.

Forced Air Cooling

It is possible with forced ventilation, to operate selenium rectifiers at 250% of their normal load current rating. This results in less expensive and more compact rectifier designs for high current applications; however, it is essential to limit the operating temperature by a sufficient volume of air. Also provisions should be made to disconnect the load if for any reason the flow of air is interrupted. All recommendations made by the manufacturer should be followed to insure long rectifier life.

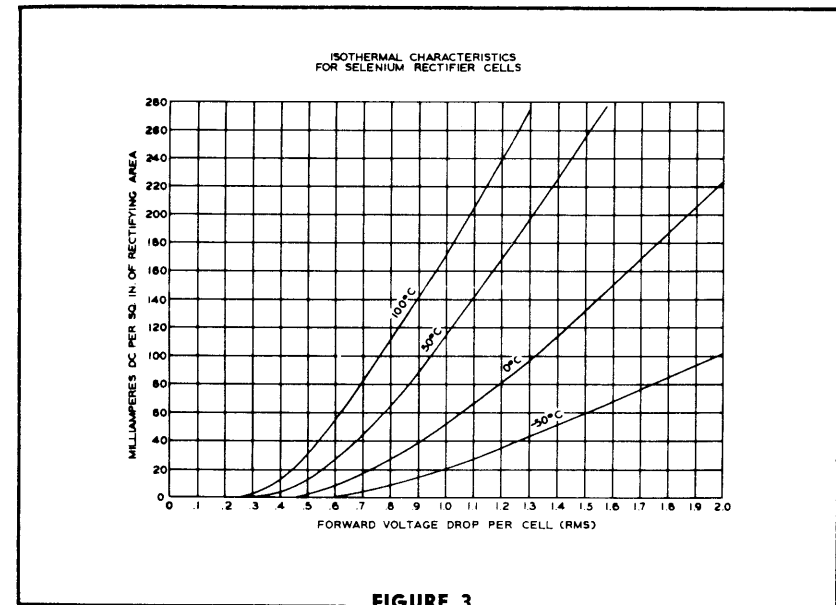

FIGURE 3

Thermal Characteristics

The selenium rectifier is a thermally as well as electrically rated device, and special consideration must be given at extreme temperature ranges. The forward and reverse resistances of selenium rectifiers are non linear with respect to temperature. Figure 5 shows the relative change in reverse resistance as the temperature is varied from -20° centigrade to $+100^{\circ}$ centigrade. Figure 3 shows the dynamic change in forward resistance at various temperatures; figure 4 shows static isothermal characteristics under the same conditions. Research in the Sarkes Tarzian laboratories has resulted in development of selenium rectifiers capable of operating, without derating in ambient temperatures as high as 90° centigrade for a minimum of 1000 hours. This new development results in extremely small rectifier designs for high temperature applications where extremely long life is not a prime requisite.

Frequency Response

By nature of their construction, selenium rectifiers have a considerable amount of inherent capacity which limits their operating range to audio frequencies. The approximate capacity ranges from .1 to .15 microfarads per square inch of rectifying area. Figure 6 shows reverse current per square inch of rectifying area versus frequency. From these data it is apparent that there is very little decrease in reverse resistance and efficiency over a frequency range of 20 to 1500 cycles per second; however the curve breaks sharply above 1500 cycles when the interelectrode capacity becomes a factor. Figure 7 shows D.C. output voltage versus frequency and it may be concluded that frequency has virtually no effect on the forward impedance of the rectifier. The output curve is flat from 20 to 20,000 cycles per second.

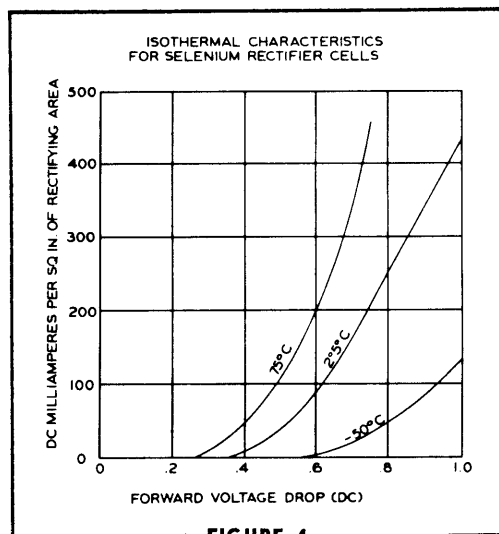

FIGURE 4

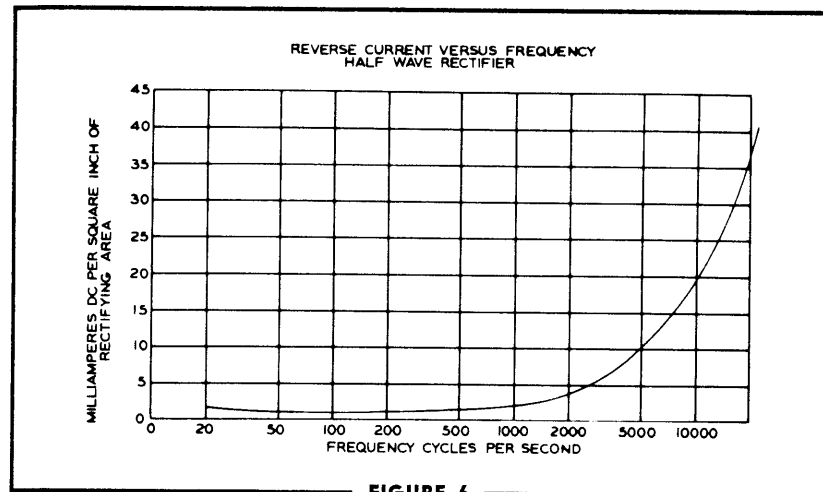

FIGURE 6

Threshold Voltage

A minimum voltage is required to make a selenium rectifier conduct in the forward direction. This voltage, commonly known as the "threshold voltage," precludes the use of selenium rectifiers at extremely low voltage (less than 1 volt) applications. The threshold voltages vary with temperature and will increase with a decrease in temperature. Figure 4 shows that under static conditions the threshold voltage will increase from .25 volts at plus 75° centigrade to .55 volts at minus 55° centigrade. Under dynamic conditions (Figure 3) the results are nearly identical; the threshold voltage increases from .25 volts at plus 100° centigrade to .6 volts at minus 50° centigrade.

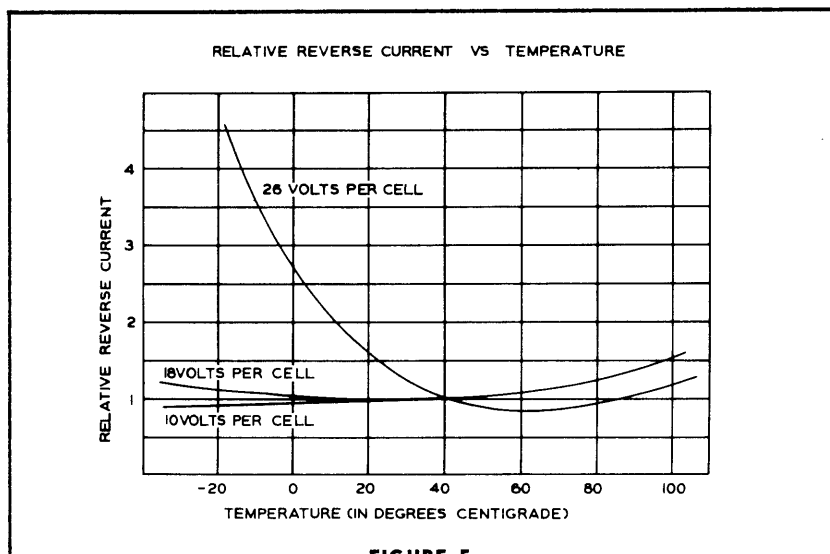

FIGURE 5

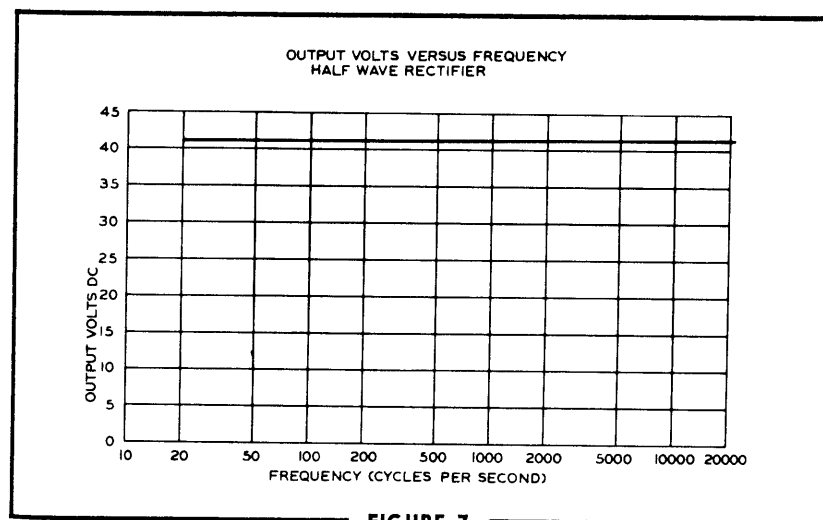
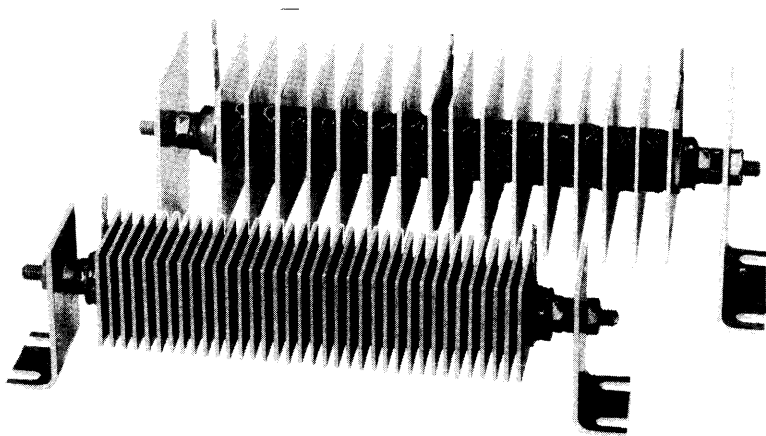

FIGURE 7

Special Applications

The unusual characteristics exhibited by selenium rectifiers have led to their wide-spread use in many special applications. For example: the non linear voltage and current relation in the conducting direction lends itself to voltage regulation wherein at normal voltages a very small current flows through the rectifier, however, as the voltage tends to increase even a fraction of one volt, the current through the rectifier increases very rapidly and the voltage decreases to its normal value, also utilization of the threshold voltage phenomena results in the use of rectifiers as protective devices shunt connected across delicate measuring equipment. The instantaneous conduction and relatively high reverse to forward resistance ratios found in selenium rectifiers have led to their use as spark quenchers in inductive circuits. Compact design for relatively large power requirements has also resulted in the popular use of selenium rectifiers in computers, calculators, and magnetic amplifiers. These are but a few of the many possible applications and are mentioned to illustrate the versatility of the rectifier. Whatever your problem on direct current circuits or power conversion, consult Sarkes Tarzian engineers.



COMMERCIAL POWER TYPE RECTIFIERS

CONVENTIONAL CIRCUITS

The Sarkes Tarzian Selenium Rectifier, in series-parallel connections provides a device that is adaptable to many applications. The most popular types of circuits in which Selenium Rectifiers are used are as follows:

1. *Single Phase—Half Wave (Figure 8-A, Page 59)*

Half wave rectification is generally used for small power applications. The ripple frequency is high since the rectifier conducts only during the positive half of the input cycle; the negative half being suppressed by the high reverse impedance of the rectifier. The ripple frequency is equal to the supply frequency. The efficiency of the half wave circuit is low and special transformer design is required to prevent poor regulation.

2. *Single Phase—Full Wave Bridge (Figure 8-B, Page 59)*

The bridge gives full wave rectification and is suitable for relatively high power applications. Efficiencies in the order of 75% are realized since both halves of the input cycle are utilized in the load. The ripple frequency is double that of the supply frequency; consequently the ripple percentage is not objectionably high for normal applications. The bridge connection is popular because of its flexibility, simplicity and utilization of an economical transformer design.

3. *Single Phase—Full Wave Center Tap (Figure 8-C, Page 59)*

As in the bridge circuit the ripple frequency of the output is double that of the supply frequency and both halves of the input cycle are utilized in the load. However transformer design is more complicated since a center tapped transformer with a terminal voltage approximately 2.7 times the load voltage is required. This connection is economical where low D. C. voltage is employed (approximately 9 volts max.).

4. *Three Phase—Half Wave (Figure 8-D, Page 59)*

The three phase—half wave connection is used in low D.C. voltage applications where cost is of primary importance and a ripple factor of 20% does not interfere. Due to the overlapping of the three phases, output current flows throughout the entire cycle with the ripple frequency three times the fundamental frequency

Special Applications

The unusual characteristics exhibited by selenium rectifiers have led to their wide-spread use in many special applications. For example: the non linear voltage and current relation in the conducting direction lends itself to voltage regulation wherein at normal voltages a very small current flows through the rectifier, however, as the voltage tends to increase even a fraction of one volt, the current through the rectifier increases very rapidly and the voltage decreases to its normal value, also utilization of the threshold voltage phenomena results in the use of rectifiers as protective devices shunt connected across delicate measuring equipment. The instantaneous conduction and relatively high reverse to forward resistance ratios found in selenium rectifiers have led to their use as spark quenchers in inductive circuits. Compact design for relatively large power requirements has also resulted in the popular use of selenium rectifiers in computers, calculators, and magnetic amplifiers. These are but a few of the many possible applications and are mentioned to illustrate the versatility of the rectifier. Whatever your problem on direct current circuits or power conversion, consult Sarkes Tarzian engineers.

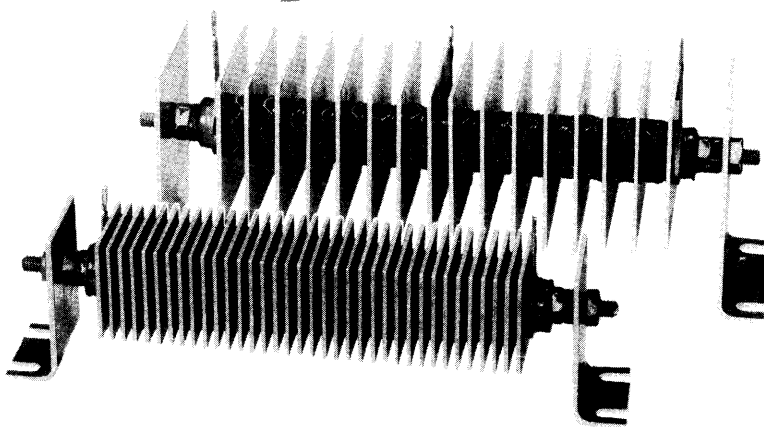

COMMERCIAL POWER TYPE RECTIFIERS

CONVENTIONAL CIRCUITS

The Sarkes Tarzian Selenium Rectifier, in series-parallel connections provides a device that is adaptable to many applications. The most popular types of circuits in which Selenium Rectifiers are used are as follows:

1. *Single Phase—Half Wave (Figure 8-A, Page 59)*

Half wave rectification is generally used for small power applications. The ripple frequency is high since the rectifier conducts only during the positive half of the input cycle; the negative half being suppressed by the high reverse impedance of the rectifier. The ripple frequency is equal to the supply frequency. The efficiency of the half wave circuit is low and special transformer design is required to prevent poor regulation.

2. *Single Phase—Full Wave Bridge (Figure 8-B, Page 59)*

The bridge gives full wave rectification and is suitable for relatively high power applications. Efficiencies in the order of 75% are realized since both halves of the input cycle are utilized in the load. The ripple frequency is double that of the supply frequency; consequently the ripple percentage is not objectionably high for normal applications. The bridge connection is popular because of its flexibility, simplicity and utilization of an economical transformer design.

3. *Single Phase—Full Wave Center Tap (Figure 8-C, Page 59)*

As in the bridge circuit the ripple frequency of the output is double that of the supply frequency and both halves of the input cycle are utilized in the load. However transformer design is more complicated since a center tapped transformer with a terminal voltage approximately 2.7 times the load voltage is required. This connection is economical where low D. C. voltage is employed (approximately 9 volts max.).

4. *Three Phase—Half Wave (Figure 8-D, Page 59)*

The three phase—half wave connection is used in low D.C. voltage applications where cost is of primary importance and a ripple factor of 20% does not interfere. Due to the overlapping of the three phases, output current flows throughout the entire cycle with the ripple frequency three times the fundamental frequency

of the source. The efficiency is higher than that of the single phase half wave connection because of better circuit utilization. Transformer design is critical for maximum regulation and efficiency.

5. Three Phase Full Wave Bridge (Figure 8-E, Page 59)

For heavy D. C. power requirements the three phase bridge is the most useful and economical circuit. The ripple component of the load current is high in frequency and is very small—approximately 4%, which frequently does not require additional filtering. However, in the event filtering is required the resulting 360 cycle ripple from a 60 cycle source may easily be filtered by chokes and condensers. The three phase full wave bridge circuit is characterized by a D. C. output voltage approximately 20% higher than the applied phase voltage.

6. Three Phase Wave Center Tap (Figure 8-F, Page 59)

The three phase, full wave center tap circuit is economical only where heavy currents are required at low D. C. voltages. A transformer with a six phase star secondary is required, (each phase winding of the secondary is provided with a center tap.)

7. D. C. Valve

The single phase half wave rectifier is frequently used in D. C. blocking and polarizing circuit as well as for discharging magnetic fields and condensers. The D. C. voltage rating per cell in blocking application is slightly below the rms rating; however, the allowable load current is higher.

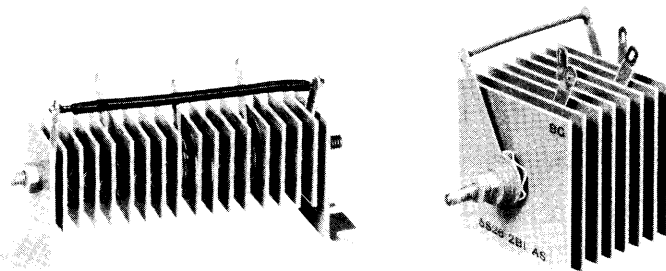

SINGLE PHASE-BRIDGE RECTIFIERS

Figure 8

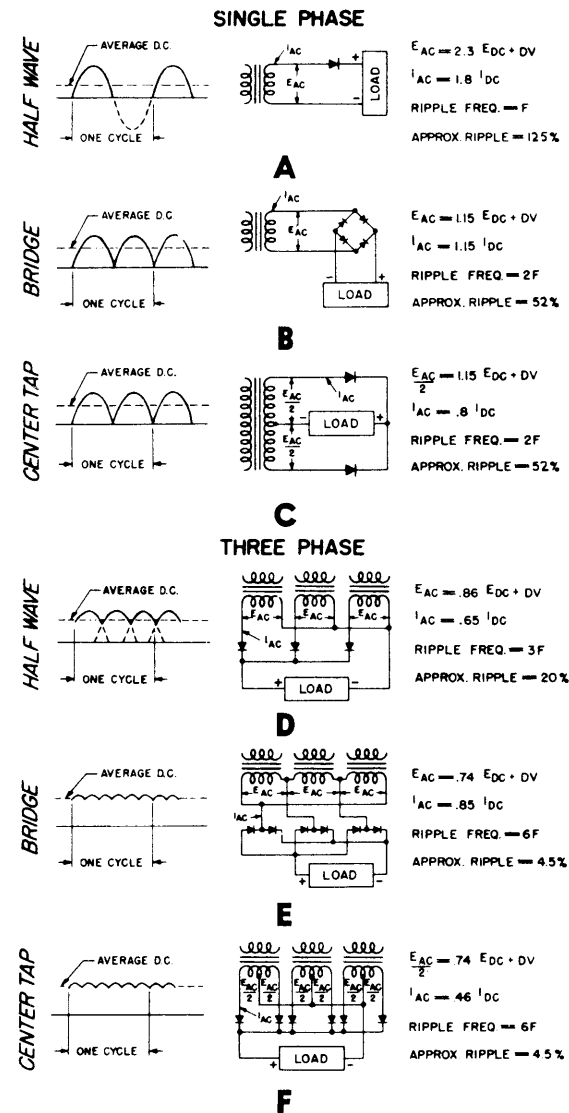

Illustrated above are the six common circuits in which Selenium Rectifiers are used, together with approximate wave shapes under resistive load, ripple frequency, ripple percentage and approximate A. C./D. C. ratio.

E_{AC} = Approx. A. C. Input Voltage (R.M.S.)

E_{DC} = Average D. C. Output Voltage

DV = Voltage drop in Rectifier (R.M.S.)

I_{DC} = Average Direct Current Output

I_{AC} = R.M.S. Alternating Current

f = Input Frequency

$\% \text{ RIPPLE} = \frac{\text{R.M.S. A.C. RIPPLE COMPONENT}}{\text{AVERAGE D.C. VOLTAGE}}$

KEY TO CODING

SARKES TARZIAN SELENIUM RECTIFIERS

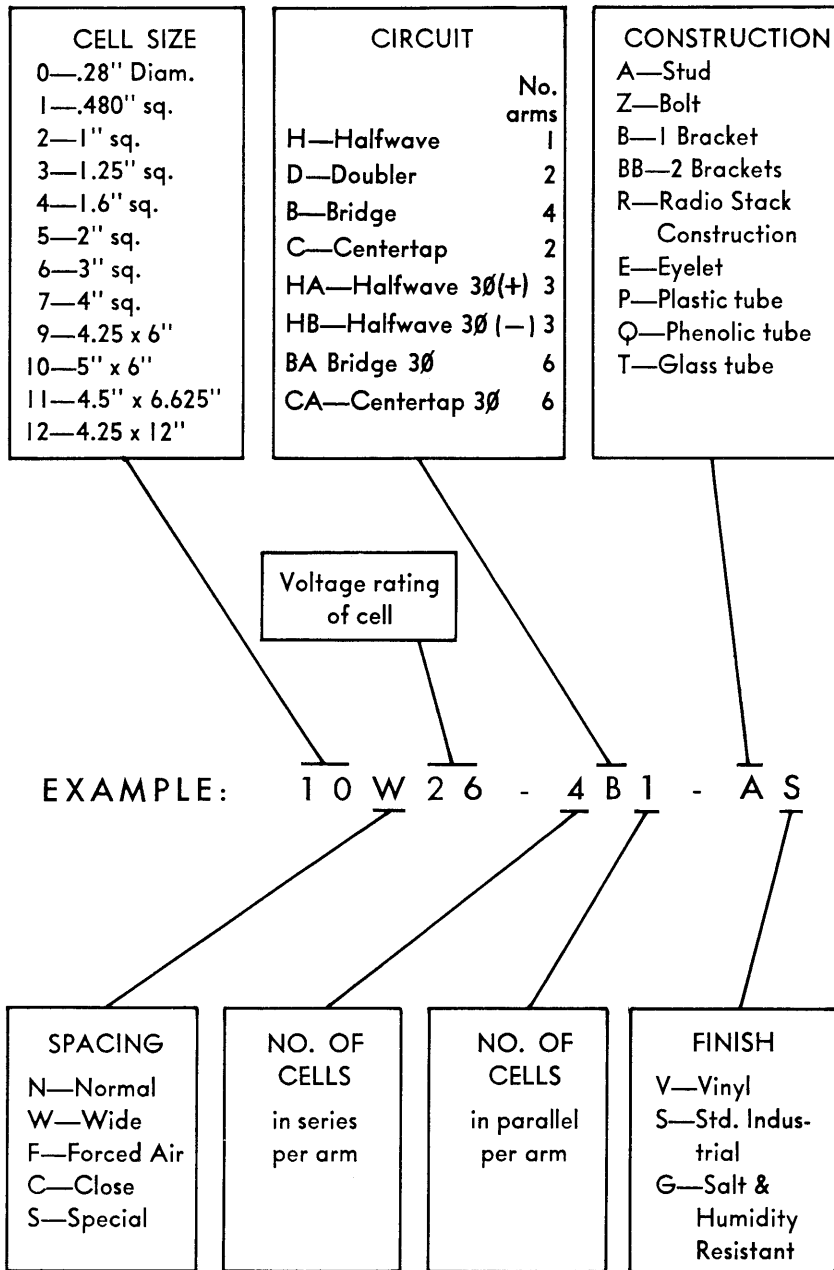

Selenium Cell Ratings

Cell No.	Cell Size	Spacing *	Max. Cells per Stack	CONTINUOUS DC AMPERES @ 45°C					
				Single Phase		Three Phase			DC Blocking
				Half Wave	Bridge and C.T.	Half Wave	Bridge	C.T.	
0	.282" d.	175	.005	.0100075
1	.475" sq.	175	.025	.050053
		N	30	.075	.150	.2	.225	.27	.12
2	1" sq.	N	16	.1	.2	.265	.3	.36	.16
		N	8	.112	.225	.3	.34	.4	.18
		W	20	.112	.225	.3	.34	.4	.18
3	1 1/4" sq.	N	30	.15	.3	.4	.45	.55	.23
		N	16	.2	.4	.53	.6	.73	.31
		N	8	.23	.45	.6	.675	.82	.35
		W	20	.23	.45	.6	.675	.82	.35
4	1.6" sq.	N	32	.3	.6	.8	.9	1.1	.45
		N	16	.375	.75	1.0	1.125	1.37	.5
		N	8	.45	.9	1.2	1.35	1.65	.67
		W	24	.45	.9	1.2	1.35	1.65	.67
5	2" sq.	N	32	.5	1	1.33	1.5	1.8	.75
		N	16	.6	1.2	1.6	1.8	2.18	.86
		N	8	.75	1.5	2	2.25	2.7	1.1
		W	24	.75	1.5	2	2.25	2.7	1.1
6	3" sq.	N	32	1	2	2.7	3	3.6	1.5
		N	16	1.165	2.33	3.14	3.5	4.2	1.75
		N	8	1.25	2.5	3.38	3.75	4.5	1.88
		W	20	1.5	3	4	4.5	5.4	2.25
7	4" sq.	N	32	2	4	5.3	6	7.2	3.2
		N	16	2.25	4.5	5.9	6.75	8.1	3.6
		N	8	2.5	5	6.6	7.5	9	4
		W	20	3	6	8	9	10.8	4.8
8	5" sq.	N	40	3.5	7	9.3	10.5	12.6	5.6
		N	16	3.9	7.9	10.4	11.8	14.1	6.3
		N	8	4.2	8.3	11.1	12.5	15	6.7
		W	24	5.3	10.5	14	15.8	18.5	8.4
9	4 1/4" x 6"	N	40	3.5	7	9.3	10.5	12.6	5.6
		N	16	3.9	7.9	10.4	11.8	14.1	6.3
		N	8	4.2	8.3	11.1	12.5	15	6.7
		W	24	5.3	10.5	14	15.8	18.5	8.4
10	5" x 6"	N	40	4	8	10.6	12	14.4	6.4
		N	16	4.5	9	11.9	13.5	16.2	7.2
		N	8	4.75	9.5	12.5	14.25	17.1	7.6
		W	24	6	12	16	18	21.6	9.6
11	4 1/2" x 6 5/8"	N	40	4	8	10.6	12	14.4	6.4
		N	16	4.5	9	11.9	13.5	16.2	7.2
		N	8	4.75	9.5	12.5	14.25	17.1	7.6
		W	24	6	12	16	18	21.6	9.6
12	4 1/4" x 12"	N	40	7.5	15	20	22.5	27	12
		N	16	8.5	16.9	22.4	25.3	30.4	13.5
		N	8	8.9	17.8	23.9	26.9	32	14.3
		W	24	11.2	22.5	30	33.8	40.5	18
14	6 1/4" x 7 1/4"	N	40	6	12	15	17	20	9
		N	16	6.5	13	16.9	18	21	10.5
		N	8	7	14	17.8	19	22	12
		W	24	9	18	22.5	24	30	14
* N—Normal Spacing W—Wide Spacing				Maximum RMS Volts per Cell 26V					Max. Blocking Volts 21.7 Vdc

Single phase current ratings are for resistive or inductive loads only. For battery, motor, or capacitive loads the ratings are 80% of values shown above. All ratings are based on normal convection cooling. For fan cooling (approximate air velocity of 500 feet per minute) multiply normal spaced ratings by 2.5.

Typical Selenium Rectifier Stacks

On succeeding pages a few of the typical selenium rectifier stack assemblies are tabulated. These will assist engineers to determine approximate physical and electrical specifications of selenium rectifiers for various power ratings. The list should be used as a guide only since the variable factors governing the design and use of selenium rectifier stacks make it impossible to compile a list which will cover every application. All tabulated rectifier designs use cells rated at 26 volts RMS per junction, however, for special applications Sarkes Tarzian engineers will often recommend 33 volt cells to conserve space or to lower cost.

Sarkes Tarzian engineers will supply complete electrical and physical specifications on custom designed rectifiers for your application—write or wire to 415 North College Avenue, Bloomington, Indiana or phone Bloomington 2-1435.

SINGLE PHASE—FULL WAVE BRIDGE

MAXIMUM D. C. VOLTS	AMPS	CODE NUMBER	Stacks Req'd Per Rating	Max. A. C. Input	APPROX. DIMENSIONS IN INCHES			Stack Connection Page 69 Fig. 10	Catalog Number	
					Fig. 9	"A"	"B"			"C"
20	0.225	2N26-1B1-AS	I	26	A	1	1 3/4	1	B-3	A-1
	0.450	3N26-1B1-AS	I	26	A	1 1/4	1 3/4	1 1/4	B-3	A-2
	0.90	4N26-1B1-AS	I	26	A	1.6	1 3/4	1.6	B-3	A-3
	1.5	5N26-1B1-AS	I	26	A	2	1 3/4	2	B-3	A-4
	2.5	6N26-1B1-AS	I	26	B	3	3	3	B-3	A-5
	5.0	7N26-1B1-AS	I	26	B	4	3	4	B-3	A-6
	8.3	9N26-1B1-AS	I	26	B	4 1/4	3	6	B-3	A-7
	9.5	10N26-1B1-AS	I	26	B	5	3	6	B-3	A-8
	17.8	12N26-1B1-AS	I	26	C	4 1/4	3	12	B-3	A-9
40	0.225	2N26-2B1-AS	I	52	A	1	2 9/16	1	B-3	A-10
	0.450	3N26-2B1-AS	I	52	A	1 1/4	2 9/16	1 1/4	B-3	A-11
	0.90	4N26-2B1-AS	I	52	A	1.6	2 9/16	1.6	B-3	A-12
	1.5	5N26-2B1-AS	I	52	A	2	2 9/16	2	B-3	A-13
	2.5	6N26-2B1-AS	I	52	B	3	4 7/8	3	B-3	A-14
	5.0	7N26-2B1-AS	I	52	B	4	4 7/8	4	B-3	A-15
	8.3	9N26-2B1-AS	I	52	B	4 1/4	4 7/8	6	B-3	A-16
	9.5	10N26-2B1-AS	I	52	B	5	4 7/8	6	B-3	A-17
	17.8	12N26-2B1-AS	I	52	C	4 1/4	4 7/8	12	B-3	A-18

FIGURE 9

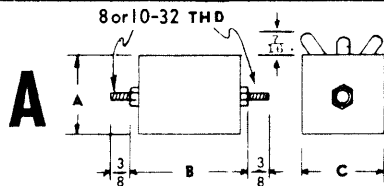

SINGLE PHASE—FULL WAVE BRIDGE (Cont'd)

MAXIMUM D. C. VOLTS	AMPS	CODE NUMBER	Stacks Req'd Per Rating	Max. A. C. Input	APPROX. DIMENSIONS IN INCHES			Stack Connection Page 69 Fig. 10	Catalog Number	
					Fig. 9	"A"	"B"			"C"
60	0.200	2N26-3B1-AS	I	78	A	1	3 3/8	1	B-3	A-19
	0.400	3N26-3B1-AS	I	78	A	1 1/4	3 3/8	1 1/4	B-3	A-20
	0.750	4N26-3B1-AS	I	78	A	1.6	3 3/8	1.6	B-3	A-21
	1.2	5N26-3B1-AS	I	78	A	2	3 3/8	2	B-3	A-22
	2.35	6N26-3B1-AS	I	78	B	3	5 7/8	3	B-3	A-23
	4.5	7N26-3B1-AS	I	78	B	4	5 7/8	4	B-3	A-24
	7.9	9N26-3B1-AS	I	78	B	4 1/4	5 7/8	6	B-3	A-25
	9.0	10N26-3B1-AS	I	78	B	5	5 7/8	6	B-3	A-26
	16.9	12N26-3B1-AS	I	78	C	4 1/4	5 7/8	12	B-3	A-27
80	0.200	2N26-4B1-AS	I	104	A	1	4 1/4	1	B-3	A-28
	0.400	3N26-4B1-AS	I	104	A	1 1/4	4 1/4	1 1/4	B-3	A-29
	0.750	4N26-4B1-AS	I	104	A	1.6	4 1/4	1.6	B-3	A-30
	1.2	5N26-4B1-AS	I	104	A	2	4 1/4	2	B-3	A-31
	2.35	6N26-4B1-AS	I	104	B	3	7 1/4	3	B-3	A-32
	4.5	7N26-4B1-AS	I	104	B	4	7 1/4	4	B-3	A-33
	7.9	9N26-4B1-AS	I	104	B	4 1/4	7 1/4	6	B-3	A-34
	9.0	10N26-4B1-AS	I	104	B	5	7 1/4	6	B-3	A-35
	16.9	12N26-4B1-AS	I	104	C	4 1/4	7 1/4	12	B-3	A-36

SINGLE PHASE—FULL WAVE BRIDGE (Cont'd)

100	0.150	2N26-5B1-AS	I	130	A	1	5 1/8	1	B-3	A-37
	0.300	3N26-5B1-AS	I	130	A	1 1/4	5 1/8	1 1/4	B-3	A-38
	0.600	4N26-5B1-AS	I	130	A	1.6	5 1/8	1.6	B-3	A-39
	1.0	5N26-5B1-AS	I	130	A	2	5 1/8	2	B-3	A-40
	2.0	6N26-5B1-AS	I	130	B	3	8 1/8	3	B-3	A-41
	4.0	7N26-5B1-AS	I	130	B	4	8 1/8	4	B-3	A-42
	7.0	9N26-5B1-AS	I	130	B	4 1/4	8 1/8	6	B-3	A-43
	8.0	10N26-5B1-AS	I	130	B	5	8 1/8	6	B-3	A-44
	15.0	12N26-5B1-AS	I	130	C	4 1/4	8 1/8	12	B-3	A-45
120	0.150	2N26-6B1-AS	I	156	A	1	5 7/8	1	B-3	A-46
	0.300	3N26-6B1-AS	I	156	A	1 1/4	5 7/8	1 1/4	B-3	A-47
	0.600	4N26-6B1-AS	I	156	A	1.6	5 7/8	1.6	B-3	A-48
	1.0	5N26-6B1-AS	I	156	A	2	5 7/8	2	B-3	A-49
	2.0	6N26-6B1-AS	I	156	B	3	10 1/8	3	B-3	A-50
	4.0	7N26-6B1-AS	I	156	B	4	10 1/8	4	B-3	A-51
	7.0	9N26-6B1-AS	I	156	B	4 1/4	10 1/8	6	B-3	A-52
	8.0	10N26-6B1-AS	I	156	B	5	10 1/8	6	B-3	A-53
	15.0	12N26-6B1-AS	I	156	C	4 1/4	10 1/8	12	B-3	A-54

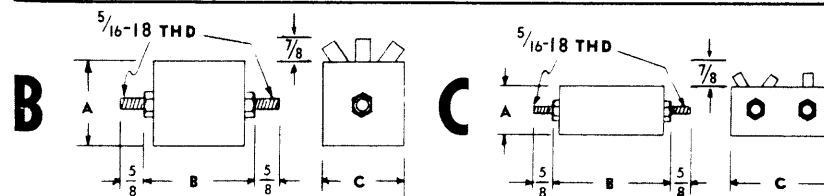

SINGLE PHASE—FULL WAVE BRIDGE (Cont'd)

MAXIMUM D. C.		CODE NUMBER	Stacks Req'd Per Rating	Max. A. C. Input	APPROX. DIMENSIONS IN INCHES			Stack Connection Page 69 Fig. 10	Catalog Number	
VOLTS	AMPS				Fig. 9	"A"	"B"			"C"
140	0.150	2N26-7BI-AS	1	182	A	1	6 $\frac{1}{8}$	1	B-3	A-55
	0.300	3N26-7BI-AS	1	182	A	1 $\frac{1}{4}$	6 $\frac{1}{8}$	1 $\frac{1}{4}$	B-3	A-56
	0.600	4N26-7BI-AS	1	182	A	1.6	6 $\frac{1}{8}$	1.6	B-3	A-57
	1.0	5N26-7BI-AS	1	182	A	2	6 $\frac{1}{8}$	2	B-3	A-58
	2.0	6N26-7BI-AS	1	182	B	3	11 $\frac{1}{2}$	3	B-3	A-59
	4.0	7N26-7BI-AS	1	182	B	4	11 $\frac{1}{2}$	4	B-3	A-60
	7.0	9N26-7BI-AS	1	182	B	4 $\frac{1}{4}$	11 $\frac{1}{2}$	6	B-3	A-61
	8.0	10N26-7BI-AS	1	182	B	5	11 $\frac{1}{2}$	6	B-3	A-62
	15.0	12N26-7BI-AS	1	182	C	4 $\frac{1}{4}$	11 $\frac{1}{2}$	12	B-3	A-63
160	0.150	2N26-8BI-AS	1	208	A	1	7 $\frac{1}{2}$	1	B-3	A-64
	0.300	3N26-8BI-AS	1	208	A	1 $\frac{1}{4}$	7 $\frac{1}{2}$	1 $\frac{1}{4}$	B-3	A-65
	0.600	4N26-8BI-AS	1	208	A	1.6	7 $\frac{1}{2}$	1.6	B-3	A-66
	1.0	5N26-8BI-AS	1	208	A	2	7 $\frac{1}{2}$	2	B-3	A-67
	2.0	6N26-8BI-AS	1	208	B	3	12 $\frac{7}{8}$	3	B-3	A-68
	4.0	7N26-8BI-AS	1	208	B	4	12 $\frac{7}{8}$	4	B-3	A-69
	7.0	9N26-8BI-AS	1	208	B	4 $\frac{1}{4}$	12 $\frac{7}{8}$	6	B-3	A-70
	8.0	10N26-8BI-AS	1	208	B	5	12 $\frac{7}{8}$	6	B-3	A-71
	15.0	12N26-8BI-AS	1	208	C	4 $\frac{1}{4}$	12 $\frac{7}{8}$	12	B-3	A-72

SINGLE PHASE—FULL WAVE BRIDGE (Cont'd)

180	0.150	2N26-9DI-AS	2	234	A	1	4 $\frac{1}{8}$	1	B-2	A-73
	0.300	3N26-9DI-AS	2	234	A	1 $\frac{1}{4}$	4 $\frac{1}{8}$	1 $\frac{1}{4}$	B-2	A-74
	0.600	4N26-9DI-AS	2	234	A	1.6	4 $\frac{1}{8}$	1.6	B-2	A-75
	1.0	5N26-9DI-AS	2	234	A	2	4 $\frac{1}{8}$	2	B-2	A-76
	2.0	6N26-9DI-AS	2	234	B	3	8	3	B-2	A-77
	4.0	7N26-9DI-AS	2	234	B	4	8	4	B-2	A-78
	7.0	9N26-9BI-AS	1	234	B	4 $\frac{1}{4}$	14 $\frac{5}{8}$	6	B-3	A-79
	8.0	10N26-9BI-AS	1	234	B	5	14 $\frac{5}{8}$	6	B-3	A-80
	15.0	12N26-9BI-AS	1	234	C	4 $\frac{1}{4}$	14 $\frac{5}{8}$	12	B-3	A-81
200	0.150	2N26-10DI-AS	2	260	A	1	5 $\frac{1}{8}$	1	B-2	A-82
	0.300	3N26-10DI-AS	2	260	A	1 $\frac{1}{4}$	5 $\frac{1}{8}$	1 $\frac{1}{4}$	B-2	A-83
	0.600	4N26-10DI-AS	2	260	A	1.6	5 $\frac{1}{8}$	1.6	B-2	A-84
	1.0	5N26-10DI-AS	2	260	A	2	5 $\frac{1}{8}$	2	B-2	A-85
	2.0	6N26-10DI-AS	2	260	B	3	8 $\frac{3}{4}$	3	B-2	A-86
	4.0	7N26-10DI-AS	2	260	B	4	8 $\frac{3}{4}$	4	B-2	A-87
	7.0	9N26-10BI-AS	1	260	B	4 $\frac{1}{4}$	15 $\frac{1}{8}$	6	B-3	A-88
	8.0	10N26-10BI-AS	1	260	B	5	15 $\frac{1}{8}$	6	B-3	A-89
	15.0	12N26-10BI-AS	1	260	C	4 $\frac{1}{4}$	15 $\frac{1}{8}$	12	B-3	A-90

FIGURE 9

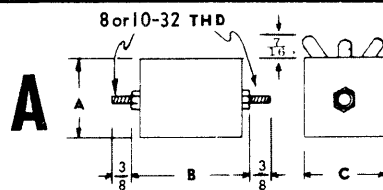

SINGLE PHASE—FULL WAVE CENTER TAP

MAXIMUM D. C.		CODE NUMBER	Stacks Req'd Per Rating	Max. A. C. Input	APPROX. DIMENSIONS IN INCHES			Stack Connection Page 69 Fig. 10	Catalog Number	
VOLTS	AMPS				Fig. 9	"A"	"B"			"C"
10	0.225	2N26-1CI-AS	1	26	A	1	1 $\frac{3}{8}$	1	C-2	A-91
	0.450	3N26-1CI-AS	1	26	A	1 $\frac{1}{4}$	1 $\frac{3}{8}$	1 $\frac{1}{4}$	C-2	A-92
	0.900	4N26-1CI-AS	1	26	A	1.6	1 $\frac{3}{8}$	1.6	C-2	A-93
	1.5	5N26-1CI-AS	1	26	A	2	1 $\frac{3}{8}$	2	C-2	A-94
	2.5	6N26-1CI-AS	1	26	B	3	2 $\frac{1}{8}$	3	C-2	A-95
	5.0	7N26-1CI-AS	1	26	B	4	2 $\frac{1}{8}$	4	C-2	A-96
	8.3	9N26-1CI-AS	1	26	B	4 $\frac{1}{4}$	2 $\frac{1}{8}$	6	C-2	A-97
	9.5	10N26-1CI-AS	1	26	B	5	2 $\frac{1}{8}$	6	C-2	A-98
	17.8	12N26-1CI-AS	1	26	C	4 $\frac{1}{4}$	2 $\frac{1}{8}$	12	C-2	A-99

THREE PHASE—FULL WAVE BRIDGE

32	0.340	2N26-1BAI-AS	1	26	A	1	2 $\frac{3}{8}$	1	BA-4	A-100
	0.675	3N26-1BAI-AS	1	26	A	1 $\frac{1}{4}$	2 $\frac{3}{8}$	1 $\frac{1}{4}$	BA-4	A-101
	1.35	4N26-1BAI-AS	1	26	A	1.6	2 $\frac{3}{8}$	1.6	BA-4	A-102
	2.25	5N26-1BAI-AS	1	26	A	2	2 $\frac{3}{8}$	2	BA-4	A-103
	3.75	6N26-1BAI-AS	1	26	B	3	3 $\frac{1}{8}$	3	BA-4	A-104
	7.5	7N26-1BAI-AS	1	26	B	4	3 $\frac{1}{8}$	4	BA-4	A-105
	12.5	9N26-1BAI-AS	1	26	B	4 $\frac{1}{4}$	3 $\frac{1}{8}$	6	BA-4	A-106
	14.25	10N26-1BAI-AS	1	26	B	5	3 $\frac{1}{8}$	6	BA-4	A-107
	26.9	12N26-1BAI-AS	1	26	C	4 $\frac{1}{4}$	3 $\frac{1}{8}$	12	BA-4	A-108
	64	0.300	2N26-2BAI-AS	1	52	A	1	3 $\frac{7}{8}$	1	BA-4
0.600		3N26-2BAI-AS	1	52	A	1 $\frac{1}{4}$	3 $\frac{7}{8}$	1 $\frac{1}{4}$	BA-4	A-110
1.125		4N26-2BAI-AS	1	52	A	1.6	3 $\frac{7}{8}$	1.6	BA-4	A-111
1.8		5N26-2BAI-AS	1	52	A	2	3 $\frac{7}{8}$	2	BA-4	A-112
3.5		6N26-2BAI-AS	1	52	B	3	5 $\frac{1}{8}$	3	BA-4	A-113
6.75		7N26-2BAI-AS	1	52	B	4	5 $\frac{1}{8}$	4	BA-4	A-114
11.8		9N26-2BAI-AS	1	52	B	4 $\frac{1}{4}$	5 $\frac{1}{8}$	6	BA-4	A-115
13.5		10N26-2BAI-AS	1	52	B	5	5 $\frac{1}{8}$	6	BA-4	A-116
25.3		12N26-2BAI-AS	1	52	C	4 $\frac{1}{4}$	5 $\frac{1}{8}$	12	BA-4	A-117

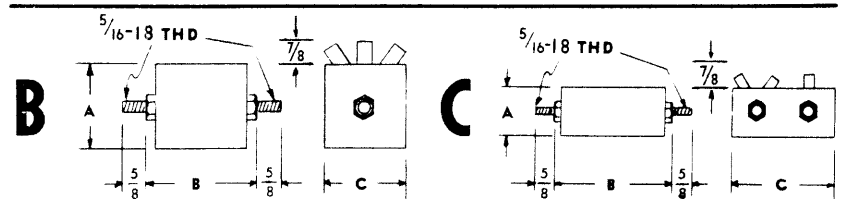

THREE PHASE—FULL WAVE BRIDGE (Cont'd)

MAXIMUM D. C.		CODE NUMBER	Stacks Req'd Per Rating	Max. A. C. Input	APPROX. DIMENSIONS IN INCHES			Stack Connection Page 69 Fig. 10	Catalog Number	
VOLTS	AMPS				Fig. 9	"A"	"B"			"C"
96	0.225	2N26-3BA1-AS	I	78	A	1	4 1/8	1	BA-4	A-118
	0.450	3N26-3BA1-AS	I	78	A	1 1/4	4 1/8	1 1/4	BA-4	A-119
	0.900	4N26-3BA1-AS	I	78	A	1.6	4 1/8	1.6	BA-4	A-120
	1.5	5N26-3BA1-AS	I	78	A	2	4 1/8	2	BA-4	A-121
	3.0	6N26-3BA1-AS	I	78	B	3	8	3	BA-4	A-122
	6.0	7N26-3BA1-AS	I	78	B	4	8	4	BA-4	A-123
	10.5	9N26-3BA1-AS	I	78	B	4 1/4	8	6	BA-4	A-124
	12.0	10N26-3BA1-AS	I	78	B	5	8	6	BA-4	A-125
	22.5	12N26-3BA1-AS	I	78	C	4 1/4	8	12	BA-4	A-126
128	0.225	2N26-4BA1-AS	I	104	A	1	5 7/8	1	BA-4	A-127
	0.450	3N26-4BA1-AS	I	104	A	1 1/4	5 7/8	1 1/4	BA-4	A-128
	0.900	4N26-4BA1-AS	I	104	A	1.6	5 7/8	1.6	BA-4	A-129
	1.5	5N26-4BA1-AS	I	104	A	2	5 7/8	2	BA-4	A-130
	3.0	6N26-4BA1-AS	I	104	B	3	10 1/8	3	BA-4	A-131
	6.0	7N26-4BA1-AS	I	104	B	4	10 1/8	4	BA-4	A-132
	10.5	9N26-4BA1-AS	I	104	B	4 1/4	10 1/8	6	BA-4	A-133
	12.0	10N26-4BA1-AS	I	104	B	5	10 1/8	6	BA-4	A-134
	22.5	12N26-4BA1-AS	I	104	C	4 1/4	10 1/8	12	BA-4	A-135

3 Phase—Half Wave—Fan Cooled Apprx. .500 PPM

15	50	12F26-1HA1-AS	I	15	C	4 1/4	2 1/2	12	HA-2	A-190
	100	12F26-1HA2-AS	I	15	C	4 1/4	3 7/8	12	HA-2	A-191
	150	12F26-1HA3-AS	I	15	C	4 1/4	4 5/8	12	HA-2	A-192
	200	12F26-1HA4-AS	I	15	C	4 1/4	6	12	HA-2	A-193
	250	12F26-1HA5-AS	I	15	C	4 1/4	6 1/8	12	HA-2	A-194
	300	12F26-1HA6-AS	I	15	C	4 1/4	8 1/8	12	HA-2	A-195
	350	12F26-1HA7-AS	I	15	C	4 1/4	8 3/8	12	HA-2	A-196
	400	12F26-1HA8-AS	I	15	C	4 1/4	10 1/4	12	HA-2	A-197
	450	12F26-1HA9-AS	I	15	C	4 1/4	10 1/8	12	HA-2	A-198
	500	12F26-1HA10-AS	I	15	C	4 1/4	12 1/8	12	HA-2	A-199

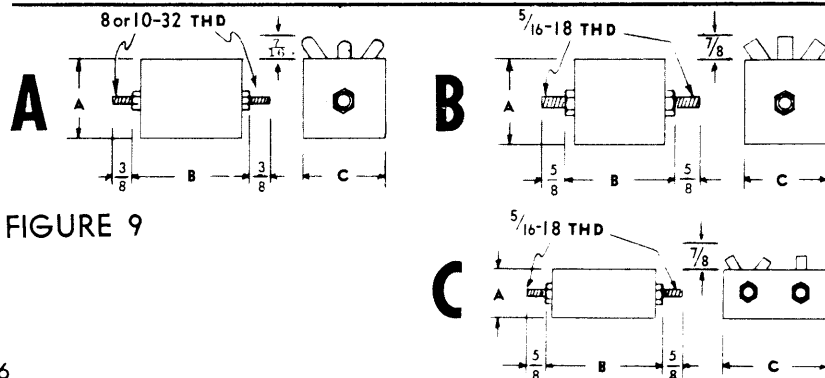

FIGURE 9

THREE PHASE—FULL WAVE BRIDGE (Cont'd)

MAXIMUM D. C.		CODE NUMBER	Stacks Req'd Per Rating	Max. A. C. Input	APPROX. DIMENSIONS IN INCHES			Stack Connection Page 69 Fig. 10	Catalog Number	
VOLTS	AMPS				Fig. 9	"A"	"B"			"C"
160	0.225	2N26-5BA1-AS	I	130	A	1	7 1/8	1	BA-4	A-136
	0.450	3N26-5BA1-AS	I	130	A	1 1/4	7 1/8	1 1/4	BA-4	A-137
	0.90	4N26-5BA1-AS	I	130	A	1.6	7 1/8	1.6	BA-4	A-138
	1.5	5N26-5BA1-AS	I	130	A	2	7 1/8	2	BA-4	A-139
	3.0	6N26-5BA1-AS	I	130	B	3	12 1/4	3	BA-4	A-140
	6.0	7N26-5BA1-AS	I	130	B	4	12 1/4	4	BA-4	A-141
	10.5	9N26-5BA1-AS	I	130	B	4 1/4	12 1/4	6	BA-4	A-142
	12.0	10N26-5BA1-AS	I	130	B	5	12 1/4	6	BA-4	A-143
	22.5	12N26-5BA1-AS	I	130	C	4 1/4	12 1/4	12	BA-4	A-144
192	0.225	2N26-6HA1-AS 2N26-6HB1-AS	I Eq.	156	A	1	5	1	BA-3	A-145
	0.450	3N26-6HA1-AS 3N26-6HB1-AS	I Eq.	156	A	1 1/4	5	1 1/4	BA-3	A-146
	0.90	4N26-6HA1-AS 4N26-6HB1-AS	I Eq.	156	A	1.6	5	1.6	BA-3	A-147
	1.5	5N26-6HA1-AS 5N26-6HB1-AS	I Eq.	156	A	2	5	2	BA-3	A-148
	3.0	6N26-6HA1-AS 6N26-6HB1-AS	I Eq.	156	B	3	8 9/16	3	BA-3	A-149
	6.0	7N26-6HA1-AS 7N26-6HB1-AS	I Eq.	156	B	4	8 9/16	4	BA-3	A-150
	10.5	9N26-6BA1-AS	I	156	B	4 1/4	14 3/8	6	BA-4	A-151
	12.0	10N26-6BA1-AS	I	156	B	5	14 3/8	6	BA-4	A-152
	22.5	12N26-6BA1-AS	I	156	C	4 1/4	14 3/8	12	BA-4	A-153

THREE PHASE—FULL WAVE BRIDGE (Cont'd)

224	0.225	2N26-7HA1-AS 2N26-7HB1-AS	I Eq.	182	A	1	5 5/8	1	BA-3	A-154
	0.450	3N26-7HA1-AS 3N26-7HB1-AS	I Eq.	182	A	1 1/4	5 5/8	1 1/4	BA-3	A-155
	0.900	4N26-7HA1-AS 4N26-7HB1-AS	I Eq.	182	A	1.6	5 5/8	1.6	BA-3	A-156
	1.5	5N26-7HA1-AS 5N26-7HB1-AS	I Eq.	182	A	2	5 5/8	2	BA-3	A-157
	3.0	6N26-7HA1-AS 6N26-7HB1-AS	I Eq.	182	B	3	9 5/8	3	BA-3	A-158
	6.0	7N26-7HA1-AS 7N26-7HB1-AS	I Eq.	182	B	4	9 5/8	4	BA-3	A-159
	10.5	9N26-7BA1-AS	I	182	B	4 1/4	16 1/2	6	BA-4	A-160
	12.0	10N26-7BA1-AS	I	182	B	5	16 1/2	6	BA-4	A-161
	22.5	12N26-7BA1-AS	I	182	C	4 1/4	16 1/2	12	BA-4	A-162
256	0.225	2N26-8HA1-AS 2N26-8HB1-AS	I Eq.	208	A	1	6 1/4	1	BA-3	A-163
	0.450	3N26-8HA1-AS 3N26-8HB1-AS	I Eq.	208	A	1 1/4	6 1/4	1 1/4	BA-3	A-164
	0.900	4N26-8HA1-AS 4N26-8HB1-AS	I Eq.	208	A	1.6	6 1/4	1.6	BA-3	A-165
	1.5	5N26-8HA1-AS 5N26-8HB1-AS	I Eq.	208	A	2	6 1/4	2	BA-3	A-166
	3.0	6N26-8HA1-AS 6N26-8HB1-AS	I Eq.	208	B	3	10 3/8	3	BA-3	A-167
	6.0	7N26-8HA1-AS 7N26-8HB1-AS	I Eq.	208	B	4	10 3/8	4	BA-3	A-168
	10.5	9N26-8HA1-AS 9N26-8HB1-AS	I Eq.	208	B	4 1/4	10 3/8	6	BA-3	A-169
	12.0	10N26-8HA1-AS 10N26-8HB1-AS	I Eq.	208	B	5	10 3/8	6	BA-3	A-170
	22.5	12N26-8HA1-AS 12N26-8HB1-AS	I Eq.	208	C	4 1/4	10 3/8	12	BA-3	A-171

THREE PHASE—FULL WAVE BRIDGE (Cont'd)

MAXIMUM D. C.		CODE NUMBER	Stacks Req'd Per Rating	Max. A. C. Input	APPROX. DIMENSIONS IN INCHES			Stack Connection Page 69 Fig. 10	Catalog Number	
VOLTS	AMPS				Fig 9	"A"	"B"			"C"
288	0.225	2N26-9HA1-AS 2N26-9HB1-AS	Eq.	234	A	1	6 ⁷ / ₈	1	BA-3	A-172
	0.450	3N26-9HA1-AS 3N26-9HB1-AS	Eq.	234	A	1 ¹ / ₄	6 ⁷ / ₈	1 ¹ / ₄	BA-3	A-173
	0.900	4N26-9HA1-AS 4N26-9HB1-AS	Eq.	234	A	1.6	6 ⁷ / ₈	1.6	BA-3	A-174
	1.5	5N26-9HA1-AS 5N26-9HB1-AS	Eq.	234	A	2	6 ⁷ / ₈	2	BA-3	A-175
	3.0	6N26-9HA1-AS 6N26-9HB1-AS	Eq.	234	B	3	11 ¹ / ₈	3	BA-3	A-176
	6.0	7N26-9HA1-AS 7N26-9HB1-AS	Eq.	234	B	4	11 ¹ / ₈	4	BA-3	A-177
	10.5	9N26-9HA1-AS 9N26-9HB1-AS	Eq.	234	B	4 ¹ / ₄	11 ¹ / ₈	6	BA-3	A-178
	12.0	10N26-9HA1-AS 10N26-9HB1-AS	Eq.	234	B	5	11 ¹ / ₈	6	BA-3	A-179
	22.5	12N26-9HA1-AS 12N26-9HB1-AS	Eq.	234	C	4 ¹ / ₄	11 ¹ / ₈	12	BA-3	A-180
320	0.225	2N26-10HA1-AS 2N26-10HB1-AS	Eq.	260	A	1	7 ¹ / ₈	1	BA-3	A-181
	0.450	3N26-10HA1-AS 3N26-10HB1-AS	Eq.	260	A	1 ¹ / ₄	7 ¹ / ₈	1 ¹ / ₄	BA-3	A-182
	0.900	4N26-10HA1-AS 4N26-10HB1-AS	Eq.	260	A	1.6	7 ¹ / ₈	1.6	BA-3	A-183
	1.5	5N26-10HA1-AS 5N26-10HB1-AS	Eq.	260	A	2	7 ¹ / ₈	2	BA-3	A-184
	3.0	6N26-10HA1-AS 6N26-10HB1-AS	Eq.	260	B	3	12 ³ / ₄	3	BA-3	A-185
	6.0	7N26-10HA1-AS 7N26-10HB1-AS	Eq.	260	B	4	12 ³ / ₄	4	BA-3	A-186
	10.5	9N26-10HA1-AS 9N26-10HB1-AS	Eq.	260	B	4 ¹ / ₄	12 ³ / ₄	6	BA-3	A-187
	12.0	10N26-10HA1-AS 10N26-10HB1-AS	Eq.	260	B	5	12 ³ / ₄	6	BA-3	A-188
	22.5	12N26-10HA1-AS 12N26-10HB1-AS	Eq.	260	C	4 ¹ / ₄	12 ³ / ₄	12	BA-3	A-189

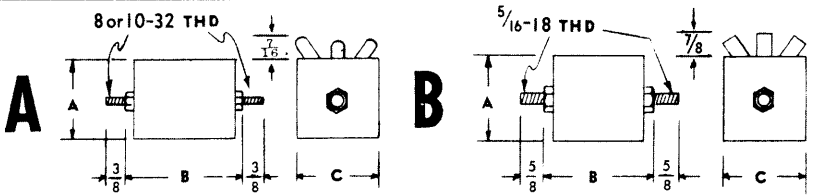
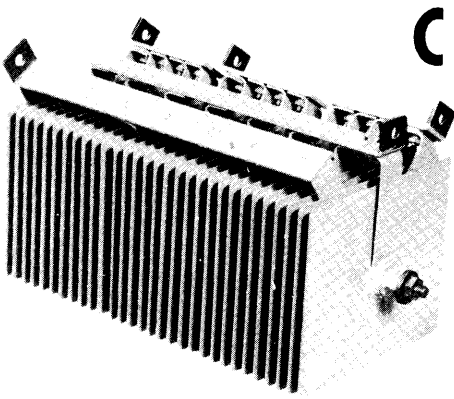

FIGURE 9



THREE PHASE
FULL WAVE BRIDGE RECTIFIER

CIRCUIT DIAGRAMS AND STACK CONNECTIONS

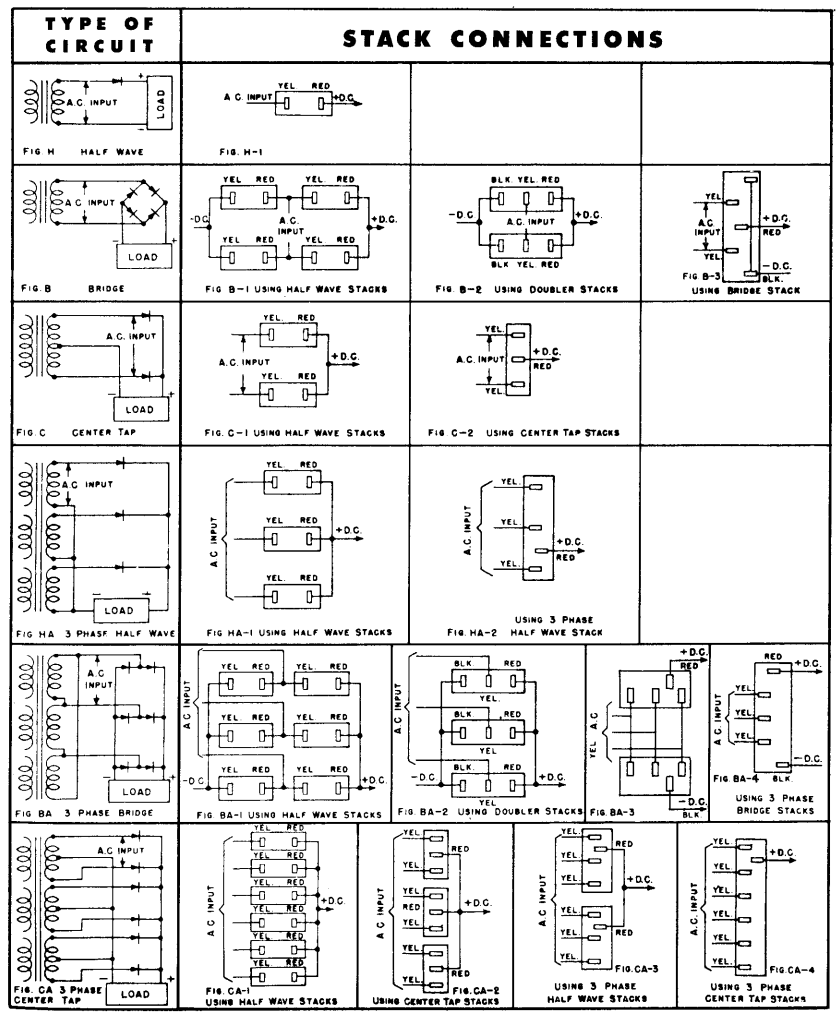

FIGURE 10

HIGH VOLTAGE SELENIUM RECTIFIERS

The Sarkes Tarzian line of low current rectifiers have found wide application in photo-flash power supplies, cathode ray oscilloscopes, high potential test equipment, and electronic equipments used by the armed services. These compact units are primarily designed for use in high voltage-low current applications; however, they are adaptable to any low current application in either half wave or full wave circuits. Sarkes Tarzian type 0 rectifiers are rated at 5 milliamperes in half wave circuits and 10 milliamperes in full wave bridge or center tap circuits. The half wave rectifier stacks are available in either glass enclosures, hermetically sealed for operation in humid or salt atmospheres or bakelite enclosures for normal commercial application. The full wave rectifiers require special sealing or potting for operation in highly humid or salt atmospheres.

Sarkes Tarzian type 1 rectifiers are rated at 25 milliamperes in half wave circuits and 50 milliamperes in full wave bridge or center tap circuits. Available in voltage ratings to 5000 volts; type 1 rectifiers allow a great saving of space even in medium power applications. Standard units are not hermetically sealed; however, for special application Type 1 rectifiers can be capsulized or sealed in metal containers.

A few typical assemblies of Sarkes Tarzian Type 0 and Type 1 rectifiers are listed at right to serve as a guide to engineers. For exact recommendations consult or write Sarkes Tarzian engineers.

Sarkes Tarzian LOW CURRENT BRIDGE RECTIFIERS

TYPE NUMBER	Max. Input Volts A. C.	Max. Peak Inverse Volts	Approx. D. C. Output Volts	Max. D. C. Milliamperes	Approximate Dimensions in Inches		Catalog Number
					"B"	Figure	
026-1B1-Q	26	37	20	10	1 3/8	1	A-200
126-1B1-Q	26	37	20	50	1 3/8	2	A-201
026-4B1-Q	104	146	80	10	1 3/8	1	A-202
126-4B1-Q	104	146	80	50	1 3/8	2	A-203
026-5B1-Q	130	182	100	10	1 9/16	1	A-204
126-5B1-Q	130	182	100	50	1 9/16	2	A-205
026-8B1-Q	208	294	160	10	2 1/16	1	A-206
126-8B1-Q	208	294	160	50	2 1/16	2	A-207
026-10B1-Q	260	368	200	10	2 3/8	1	A-208
126-10B1-Q	260	368	200	50	2 3/8	2	A-209
026-15B1-Q	390	552	300	10	3 1/8	1	A-210
126-15B1-Q	390	552	300	50	3 1/8	2	A-211
026-20B1-Q	520	736	400	10	3 15/16	1	A-212
126-20B1-Q	520	736	400	50	3 15/16	2	A-213
026-25B1-Q	650	920	500	10	4 3/4	1	A-214
126-25B1-Q	650	920	500	50	4 3/4	2	A-215
026-30B1-Q	780	1105	600	10	5 9/16	1	A-216
126-30B1-Q	780	1105	600	50	5 9/16	2	A-217
026-35B1-Q	910	1290	700	10	6 3/8	1	A-218
126-35B1-Q	910	1290	700	50	6 3/8	2	A-219

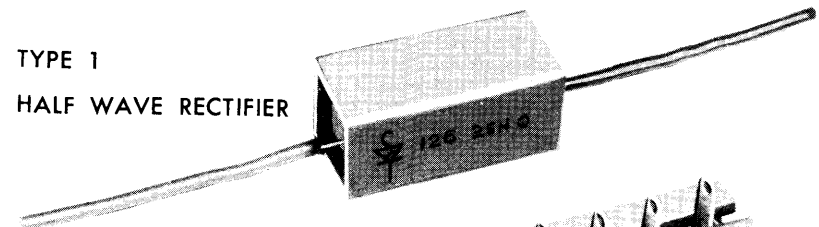

TYPE 1
HALF WAVE RECTIFIER

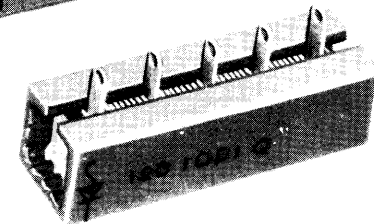

TYPE 1
BRIDGE RECTIFIER



HIGH VOLTAGE HALF WAVE SELENIUM RECTIFIERS

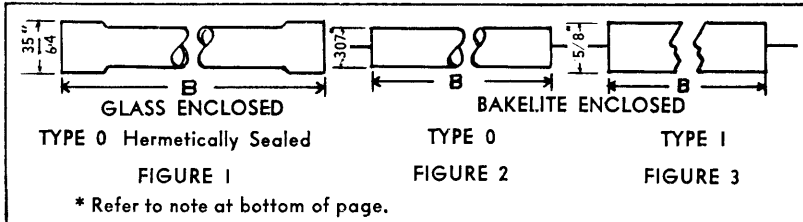

TYPE NUMBER	Max. R.M.S. Inverse Volts	Max. A.C. Input Cap.	Max. Peak Inverse Volts	Approx. D. C. Output Volts		Approx. C-MFD Cap. Input	Max. D.C. M.A.	Dimensions in Inches		Catalog Number
				Resistive	Capacitive			"B"	Fig.	
026-10H-T	260	130	370	105	130	1.5	5	1 3/4	1	A-220
026-10H-Q	260	130	370	105	130	1.5	5	1 5/16	2	A-221
126-10H-Q	260	130	370	105	130	7.7	25	1 5/16	3	A-222
026-20H-T	520	260	740	210	260	.77	5	1 3/4	1	A-223
026-20H-Q	520	260	740	210	260	.77	5	1 5/16	2	A-224
126-20H-Q	520	260	740	210	260	3.8	25	1 5/16	3	A-225
026-50H-T	1300	650	1850	525	650	.31	5	3/4	1	A-226
026-50H-Q	1300	650	1850	525	650	.31	5	2/2	2	A-227
126-50H-Q	1300	650	1850	525	650	1.5	25	2/2	3	A-228
026-75H-T	1950	975	2760	790	975	.21	5	3/4	1	A-229
026-75H-Q	1950	975	2760	790	975	.21	5	3/2	2	A-230
126-75H-Q	1950	975	2760	790	975	1	25	3/2	3	A-231
026-100H-T	2600	1300	3700	1050	1300	.15	5	4/4	1	A-232
026-100H-Q	2600	1300	3700	1050	1300	.15	5	4/2	2	A-233
126-100H-Q	2600	1300	3700	1050	1300	.77	25	4/2	3	A-234
026-125H-T	3250	1625	4600	1320	1625	.12	5	6	1	A-235
026-125H-Q	3250	1625	4600	1320	1625	.12	5	5 7/16	2	A-236
126-125H-Q	3250	1625	4600	1320	1625	.62	25	5 7/16	3	A-237
026-150H-T	3900	1950	5515	1575	1950	.10	5	6	1	A-238
026-150H-Q	3900	1950	5515	1575	1950	.10	5	6 7/16	2	A-239
126-150H-Q	3900	1950	5515	1575	1950	.51	25	6 7/16	3	A-240
026-175H-T	4550	2275	6430	1840	2275	.09	5	7	1	A-241
026-175H-Q	4550	2275	6430	1840	2275	.09	5	7 7/16	2	A-242
126-175H-Q	4550	2275	6430	1840	2275	.44	25	7 7/16	3	A-243

* Note: Sarkes Tarzian type O rectifiers are also available in bakelite enclosures, with ferrule mounting and are electrically and mechanically equivalent to listed "T" assemblies. These will meet all J.A.N. vibration, shock and acceleration requirements. Write for complete information.

TYPE 0 BAKELITE ENCLOSED RECTIFIER

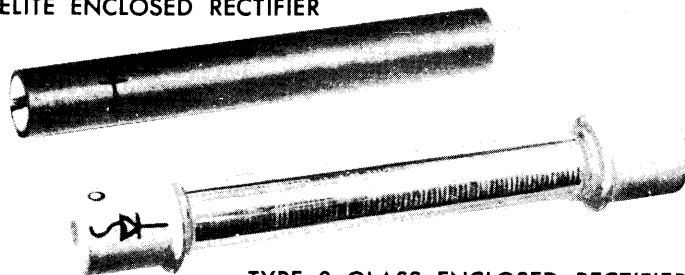

TYPE 0 GLASS ENCLOSED RECTIFIER



"Centre-Kooled" POWER RECTIFIERS

SINGLE PHASE - FULL WAVE RECTIFIER STACKS

DC OUTPUT At 35°C. Amb.	CIRCUIT	Max. AC Input	APPROXIMATE DIMENSIONS—Refer to			Figure	Catalog	CIRCUITS AND DIMENSIONAL DIAGRAMS
			A	B	C			
6-10	2 C.T.	13	3"	2 1/8"	3"	2	D-10	
6-10	4 C.T.	13	4"	2 1/8"	4"	2	D-11	
6-10	6 C.T.	13	4"	2 1/2"	4"	2	D-12	
6-10	8 C.T.	13	5"	2 1/8"	6"	2	D-13	
6-10	12 C.T.	13	5"	2 1/2"	6"	2	D-14	
6-10	15 C.T.	13	4 1/4"	2 1/8"	12"	3	D-15	
6-10	22.5 C.T.	13	4 1/4"	2 1/2"	12"	3	D-16	
6-20	2 BR.	26	3"	2 7/8"	3"	2	D-17	
6-20	4 BR.	26	4"	2 7/8"	4"	2	D-18	
6-20	6 BR.	26	4"	3 5/8"	4"	2	D-19	
6-20	8 BR.	26	5"	2 7/8"	6"	2	D-20	
6-20	12 BR.	26	5"	3 5/8"	6"	2	D-21	
6-20	15 BR.	26	4 1/4"	2 7/8"	12"	3	D-22	
6-20	22.5 BR.	26	4 1/4"	3 5/8"	12"	3	D-23	
20-40	2 BR.	52	3"	4 1/4"	3"	2	D-24	
20-40	4 BR.	52	4"	4 1/4"	4"	2	D-25	
20-40	6 BR.	52	4"	6"	4"	2	D-26	
20-40	8 BR.	52	5"	4 1/4"	6"	2	D-27	
20-40	12 BR.	52	5"	6"	6"	2	D-28	
20-40	15 BR.	52	4 1/4"	4 1/4"	12"	3	D-29	
20-40	22.5 BR.	52	4 1/4"	6"	12"	3	D-30	
40-60	2 BR.	78	3"	5 3/4"	3"	2	D-31	
40-60	4 BR.	78	4"	5 3/4"	4"	2	D-32	
40-60	6 BR.	78	4"	8 1/4"	4"	2	D-33	
40-60	8 BR.	78	5"	5 3/4"	6"	2	D-34	
40-60	12 BR.	78	5"	8 1/4"	6"	2	D-35	
40-60	15 BR.	78	4 1/4"	5 3/4"	12"	3	D-36	
40-60	22.5 BR.	78	4 1/4"	8 1/4"	12"	3	D-37	
60-100	.5 BR.	130	1.6"	5"	1.6"	1	D-38	
60-100	1 BR.	130	2"	5"	2"	1	D-39	
60-100	2 BR.	130	3"	8 1/2"	3"	2	D-40	
60-100	4 BR.	130	4"	8 1/2"	4"	2	D-41	
60-100	6 BR.	130	4"	12 7/8"	4"	2	D-42	
60-100	8 BR.	130	5"	8 1/2"	6"	2	D-43	
60-100	12 BR.	130	5"	12 7/8"	6"	2	D-44	
100-120	.5 BR.	156	1.6"	5 7/8"	1.6"	1	D-45	
100-120	1 BR.	156	2"	5 7/8"	2"	1	D-46	
100-120	2 BR.	156	3"	9 7/8"	3"	2	D-47	
100-120	4 BR.	156	4"	9 7/8"	4"	2	D-48	
100-120	6 BR.	156	4"	15 1/8"	4"	2	D-49	
100-120	8 BR.	156	5"	9 7/8"	6"	2	D-50	
100-120	12 BR.	156	5"	15 1/8"	6"	2	D-51	

ALL DIMENSIONS ARE APPROXIMATE



HIGH VOLTAGE HALF WAVE SELENIUM RECTIFIERS

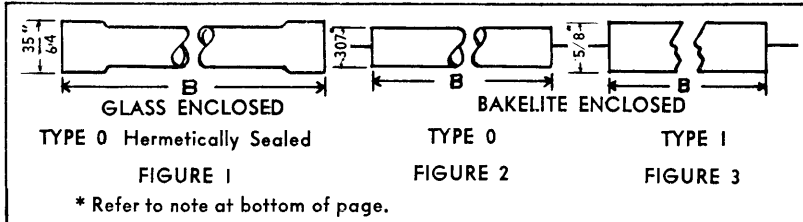

TYPE NUMBER	Max. R.M.S. Inverse Volts	Max. A.C. Input Cap.	Max. Peak Inverse Volts	Approx. D. C. Output Volts		Approx. C-MFD Cap. Input	Max. D.C. M.A.	Dimensions in Inches		Catalog Number
				Resistive	Capacitive			"B"	Fig.	
026-10H-T	260	130	370	105	130	1.5	5	1 3/4	1	A-220
026-10H-Q	260	130	370	105	130	1.5	5	1 5/16	2	A-221
126-10H-T	260	130	370	105	130	7.7	25	1 5/16	3	A-222
026-20H-T	520	260	740	210	260	.77	5	1 3/4	1	A-223
026-20H-Q	520	260	740	210	260	.77	5	1 5/16	2	A-224
126-20H-T	520	260	740	210	260	3.8	25	1 5/16	3	A-225
026-50H-T	1300	650	1850	525	650	.31	5	3/4	1	A-226
026-50H-Q	1300	650	1850	525	650	.31	5	2/2	2	A-227
126-50H-T	1300	650	1850	525	650	1.5	25	2/2	3	A-228
026-75H-T	1950	975	2760	790	975	.21	5	3/4	1	A-229
026-75H-Q	1950	975	2760	790	975	.21	5	3/2	2	A-230
126-75H-T	1950	975	2760	790	975	1	25	3/2	3	A-231
026-100H-T	2600	1300	3700	1050	1300	.15	5	4/2	1	A-232
026-100H-Q	2600	1300	3700	1050	1300	.15	5	4/2	2	A-233
126-100H-T	2600	1300	3700	1050	1300	.77	25	4/2	3	A-234
026-125H-T	3250	1625	4600	1320	1625	.12	5	6	1	A-235
026-125H-Q	3250	1625	4600	1320	1625	.12	5	5 7/16	2	A-236
126-125H-T	3250	1625	4600	1320	1625	.62	25	5 7/16	3	A-237
026-150H-T	3900	1950	5515	1575	1950	.10	5	6	1	A-238
026-150H-Q	3900	1950	5515	1575	1950	.10	5	6 7/16	2	A-239
126-150H-T	3900	1950	5515	1575	1950	.51	25	6 7/16	3	A-240
026-175H-T	4550	2275	6430	1840	2275	.09	5	7	1	A-241
026-175H-Q	4550	2275	6430	1840	2275	.09	5	7 7/16	2	A-242
126-175H-T	4550	2275	6430	1840	2275	.44	25	7 7/16	3	A-243

* Note: Sarkes Tarzian type O rectifiers are also available in bakelite enclosures, with ferrule mounting and are electrically and mechanically equivalent to listed "T" assemblies. These will meet all J.A.N. vibration, shock and acceleration requirements. Write for complete information.

TYPE 0 BAKELITE ENCLOSED RECTIFIER

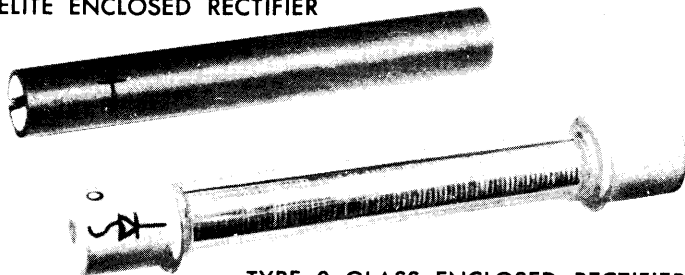

TYPE 0 GLASS ENCLOSED RECTIFIER



"Centre-Kooled" POWER RECTIFIERS

SINGLE PHASE - FULL WAVE RECTIFIER STACKS

DC OUTPUT At 35°C. Amb.	CIRCUIT	Max. AC Input Volts	APPROXIMATE DIMENSIONS—Refer to Figure			Catalog	CIRCUITS AND DIMENSIONAL DIAGRAMS	
			A	B	C			
6-10	2 C.T.	13	3"	2 1/8"	3"	2		
6-10	4 C.T.	13	4"	2 1/8"	4"	2		
6-10	6 C.T.	13	4"	2 1/2"	4"	2		
6-10	8 C.T.	13	5"	2 1/8"	6"	2		
6-10	12 C.T.	13	5"	2 1/2"	6"	2		
6-10	15 C.T.	13	4 1/4"	2 1/4"	12"	3		
6-10	22.5 C.T.	13	4 1/4"	2 1/2"	12"	3		
6-20	2 BR.	26	3"	2 7/8"	3"	2		
6-20	4 BR.	26	4"	2 7/8"	4"	2		
6-20	6 BR.	26	4"	3 5/8"	4"	2		
6-20	8 BR.	26	5"	2 7/8"	6"	2		
6-20	12 BR.	26	5"	3 5/8"	6"	2		
6-20	15 BR.	26	4 1/4"	2 7/8"	12"	3		
6-20	22.5 BR.	26	4 1/4"	3 5/8"	12"	3		
20-40	2 BR.	52	3"	4 1/4"	3"	2		
20-40	4 BR.	52	4"	4 1/4"	4"	2		
20-40	6 BR.	52	4"	6"	4"	2		
20-40	8 BR.	52	5"	4 1/4"	6"	2		
20-40	12 BR.	52	5"	6"	6"	2		
20-40	15 BR.	52	4 1/4"	4 1/4"	12"	3		
20-40	22.5 BR.	52	4 1/4"	6"	12"	3		
40-60	2 BR.	78	3"	5 3/4"	3"	2		
40-60	4 BR.	78	4"	5 3/4"	4"	2		
40-60	6 BR.	78	4"	8 1/4"	4"	2		
40-60	8 BR.	78	5"	5 3/4"	6"	2		
40-60	12 BR.	78	5"	8 1/4"	6"	2		
40-60	15 BR.	78	4 1/4"	5 3/4"	12"	3		
40-60	22.5 BR.	78	4 1/4"	8 1/4"	12"	3		
60-100	.5 BR.	130	1.6"	5"	1.6"	1		
60-100	1 BR.	130	2"	5"	2"	1		
60-100	2 BR.	130	3"	8 1/2"	3"	2		
60-100	4 BR.	130	4"	8 1/2"	4"	2		
60-100	6 BR.	130	4"	12 7/8"	4"	2		
60-100	8 BR.	130	5"	8 1/2"	6"	2		
60-100	12 BR.	130	5"	12 7/8"	6"	2		
100-120	.5 BR.	156	1.6"	5 7/8"	1.6"	1		
100-120	1 BR.	156	2"	5 7/8"	2"	1		
100-120	2 BR.	156	3"	9 7/8"	3"	2		
100-120	4 BR.	156	4"	9 7/8"	4"	2		
100-120	6 BR.	156	4"	15 1/8"	4"	2		
100-120	8 BR.	156	5"	9 7/8"	6"	2		
100-120	12 BR.	156	5"	15 1/8"	6"	2		

ALL DIMENSIONS ARE APPROXIMATE

SECTION 3

Selenium Rectifier Replacement Guide

Television

Manufacturer	Manufacturer's Model No.	Manufacturer's Chassis No.	Manufacturer's Part No.	Sarkes Tarzian Model No.		
ADMIRAL	4H Series	30 Series	93A-2	71		
	8C Series	30 Series	93A-2	71		
	30A Series	30 Series	93A-2	71		
	30B Series	30 Series	93A-2	71		
	30C Series	30 Series	93A-2	71		
AIRLINE	84G Series		MW57E3	200		
	84HA Series		27B147	200		
	94BR Series		B-21J-16196	250		
	94GSE-3015		MW57E3	200		
ANCHOR	ARC-101-50TV		A-16A-4	126-10H-Q		
ASTATIC	AT-1		A-5054	65		
	BT-1 & 2		A-5054	65		
	EA-2 & 3		A-5054	65		
AUTOMATIC	AR-TV-707-709-710			200		
	TV-P490			200		
	TV-12-49			250		
	TV-12-50			250		
CAPEHART	3000 Series	C-272	650150D-5	65		
	3000 Series	C-272	650150D-4	458		
	3000 Series	C-276	650150D-4	65		
			650150D-5	458		
CONSOLIDATED	2315			200		
				150		
CORONADO	FA43 Series		B-21J-15661	150		
			B-21J-16196	250		
CROSLEY	9-425		C-146924-54	150		
EMERSON	500 Series	120000 Series	817004	250		
			817005	200		
			817004	250		
	600 Series	120000 Series	817005	200		
			817006	450		
			817007	250		
			817008	450		
			817009	250		
			817013	250		
			817015	250		
			817017	250		
FIRESTONE	13G Series			200		
GAROD	10TZ Series		B-36.132	150		
	12TZ Series		B-36.132	150		
	15TZ Series		B-36.132	150		
			B-36.135	200		
GENERAL ELECTRIC	800 Series	T-S-U-W Series	K-69J610	250		
			K-71J40	250		
	10C Series		K71J128	450		
			K71J164-1	350		
			K71J387	350		

Manufacturer	Manufacturer's Model No.	Manufacturer's Chassis No.	Manufacturer's Part No.	Sarkes Tarzian Model No.	
HALLICRAFTERS	T-54		27B147	200	
	500 Series		27B147	200	
	800 Series		27A151	150	
			27A155	300	
MASCO	MB-2		RS-40	65	
	MB-3		RS-65	65	
MECK	XA, XB & XC			200	
MOTOROLA	VT Series	TS Series	48B471350	200	
			48B470395	150	
	7VT Series	TS Series	48B470395	150	
	9VT Series	TS Series	48B470395	150	
	10 Series	TS-14 Series	48B780584	250	
	12VK15	TS Series	48B791092	65	
	12VK11-13	TS-23 Series	48B780584	250	
	12VF Series	TS-23 Series	48B780584	250	
	16F1	TS-60	48B791694	450	
	16K2L	TS-52	48B791694	450	
	16VF8	TS Series	48B791092	65	
	16VK1	TS-52	48B79694	450	
	16VK7	TS-Series	48B791092	65	
	16T1	TS-60	48B791694	450	
			48B700555	300	
	NATIONAL	NC-TV7 Series		K-928-1	200
PACKARD-BELL	2991-TV		7003	200	
			72003	200	
PHILCO	49 Series	120 Series	34-8003-4	208	
			34-8003-5	458	
			34-8003-2	150	
	50 Series	120 Series	34-8003-4	208	
			34-8003-5	458	
51 Series	120 Series	34-8003-7	450		
RADIO CRAFTSMEN	RC-100		13X001	208	
			13X002	78	
RAYTHEON	A-7DX22P	Series A	B-21J-15661	150	
			B-21J-16196	250	
			B-21J-16196	250	
	A-10DX Series	A, B, C, D	B-21J-16196	250	
			B-21J-15661	150	
	B-10DX2	A, B, C, D	B-21J-16196	250	
	P-301A-B		B-21J-15661	150	
	7DX21	Series B	B-21J-15661	150	
	10AXF43	A, B, C, D	A-21J-12775	100	
10DX Series	A, B, C, D	B-21J-16196	250		
18DX Series		B-21J-15661	150		
RCA VICTOR	2T Series	KCS45	B-940267-2	300	
	4T Series	KCS61-62	B-940267-2	300	
REGENCY	DB-213		M-1	35	
SENTINEL	400TV		57E3	150	
	401 Series		57E3	150	
	402 Series		57E3	150	
	405 Series		57E3	150	
	406 Series		57E3	150	
	407		57E3	150	
	409		57E3	150	
	STEWART-WARNER	9100 Series		507582	250
				507301	250
			507301	250	
			507301	250	
AVC-1-2-3	9054 Series		507301	250	
			507301	250	
AVT-1	9054A		507301	250	

Manufacturer	Manufacturer's Model No.	Manufacturer's Chassis No.	Manufacturer's Part No.	Sarkes Tarzian Model No.
SYLVANIA	I-075	I-139	517001	250
	I-076	I-108	517001	250
	I-090	I-168	517003	250
	I-113	I-139	517001	250
	I-114	I-139	517001	250
	I-124	I-139	517001	250
	I-125	I-139	517001	250
	I-177	I-186	517001	250
	I-210	I-139	517001	250
	TECH-MASTER	5016		
TELE-KING	210		XR-1	71
	310		XR-1	71
			SR-300	300
TELE-TONE	TV149		TSR-100	100
	TV170		TSR-102	250
	TV208TR	TR	TSR-100	100
	TV220	TR	TSR-100	100
	TV250	TK	TSR-104D	250
	TV254	TK	TSR-104-D	250
			TSR-106-D	300
		TSR-107-D	150	
TRUETONE	D1990		B-21J-16196	250
	D1992		B-21J16196	250
	D2982		57E3	150
	D2985		B-21J-15661	150
	D2987		B-21J-16196	250
WILCOX-GAY	9W Series		SRI-2	200

Radio

ADMIRAL	4R Series	4R Series	93A 1-6	65	
	4TI	4TI	93A 1-6	65	
	4W Series	4WI	93A 1-6	65	
	5F Series	5FI	93A 1-4	75	
	6C11	6C1	93A 1-4	75	
	6Q Series	6Q1	93A 1-2	100	
	6R Series	6R1	93A 1-2	100	
	6W Series	6W1	93A 1-4	75	
	6Y Series	6Y1	93A 1-4	75	
	7P Series	5H1	93A 1-2	75	
	AIRCADLE	DM700			75
		EV760			75
		G521			75
G725			ED2	75	
SC-448			3004	75	
WRA1-A			485001	75	
WRA-4M			A-801	75	
5000 Series			SR-1	75	
10005			RS-10000	100	
11305			A83-391	75	
114114			A83-561	150	
120000 Series			A83-463	150	
131504			A83-463	150	
147114			A83-568	75	
AIR CHIEF		4-A-12		A-58612	100
		4-C-5	291-7-574	57E1-2	65
	4-C-13			75	

Manufacturer	Manufacturer's Model No.	Manufacturer's Chassis No.	Manufacturer's Part No.	Sarkes Tarzian Model No.
AIR KING	Royal		PA-51160	75
	A-510		PA-51160	75
AIRLINE	64WG Series		66X7 or 25A1019	100
	74 Series		BEA-21J-12775	100
			26002	100
			25A1019	100
			66X7	100
	84 Series		A-21J-12775	100
			66X7	100
			66X8	75
	94 Series		A-21J-12775	100
			66X7	100
ALDEN	1562		ED-2	150
	1636L		ED-2	150
	1800 Series		SR-75	75
		SR-1	75	
		ED1	75	
ARVIN	150TC	RE228-1	A20207-2	100
	151TC	RE228-1	A20207-2	100
	182TFM	RE237	A20207-3	150
	241P	RE244	A20207-1	75
		RE254		
		RE255		
		RE256		
		RE259		
	244P	RE244	A20207-1	75
		RE254		
		RE255		
		RE256		
		RE259		
	250P	RE248	A20207-1	75
	280 Series	RE253	A20207-3	150
350 Series	RE267	C20207-2	100	
360 Series	RE260	C20207-3	150	
AUTOMATIC RADIO	Tom Thumb			75
	ATTP		SR-100	100
	C-60X		SR-75	75
	M-92C		RX-92C	1204CB
	677	B Series		100
BELMONT	A-7AF21	Series A	A-21J-12275	100
	A-7DF21	Series A	CR-1	100
BENDIX	69 Series		QR0S01	100
	75 Series		QR0S01	100
	697A		QR0S00	150
CLARION	147 Series		A-83-568	75
	11000 Series		A83-391	75
	12000 Series		A83-463	150
	13101		A83-463	150
CROSLLEY	9-302	200 Series	B-143883-2	75
	10 Series	200 Series	B-145370	100
			B-145429	65
DELCO	R-1410		121683	75
DEWALD	B-504 & 515		8018A	75
	D-508 & 508A		8018A	75
EMERSON	500 Series	120000 Series	817101	100
	600 Series	120000 Series	817101	100
			817102	100
	600 Series	130132B	817101	100
			817102	100

Manufacturer	Manufacturer's Model No.	Manufacturer's Chassis No.	Manufacturer's Part No.	Sarkes Tarzian Model No.
FADA	P80		112.6	100
	P111		112.18	75
	P130		112.6	100
GAROD	5D-4 & 5		36.111	75
	5K-1		36.130	100
GENERAL ELECTRIC	140 Series		REX-004	75
			REX-005	100
	150		REX-001	100
	160		REX-001	100
	165		REX-001	100
	250		REX-001	100
	260		REX-001	100
HALLICRAFTERS	S-72		27A151	150
HOFFMAN	A-700	100 or 110S	9517	100
HOWARD	474		SR-0003	75
JEWELL	500		34	65
	505		XI	65
	801			65
	949			75
KNIGHT	4B-170		SR1	75
	5B-171		SR1	75
	5C Series		A83-391	75
	6B Series		SR1	75
	7B-220		57E1	100
	7C-220		57E1	100
	449		57E1	100
LAFAYETTE	J4			150
	1-422		175-1	75
	1-427			150
LEAR RADIO	WC-311-D		62094	200
			61191	100
MAGNACORD	AD-1R		2044-8	100
MANTOLA	R-652-652N		93A1-2	100
	R-76162		A58612	100
	R-76262		A58612	100
MECK	CM-500	5D7-W18		75
	DE-640		RS-10000	100
	DF-641		RS-10000	100
	EV-760			75
MEISSNER	6H		29375	100
	661		29375	100
MIDWEST	P-6		CR-1	75
	P-86		CR-1	75
MONITOR	M-510			100
MINERVA	410			100
	411			100
MOTOROLA	5A Series	HS-62-A	48B478111	75
	58L11	HS-114	48B478111	75
	59L Series	HS-187	48B478111	75
	67L11	HS-59	48B470938	75

Manufacturer	Manufacturer's Model No.	Manufacturer's Chassis No.	Manufacturer's Part No.	Sarkes Tarzian Model No.
MOTOROLA— (Cont.)	67XM21	HS-64	48B90140	100
	68L11	HS-119	48B478111	75
	68T11	HS-144	48B90140	100
	69L11	HS-175	48B-78111	75
	77FM Series	HS-89 & HS-97	48B90140	100
	77XM Series	HS-102	48B90140	100
	78FM Series	HS-128 & HS-132	48B90140	100
	78F Series	HS-150 & HS-155	48B48207	150
	79FM Series	HS-178	48B48207	150
	79XM Series	HS-168	48B48207	150
	88FM21	HS-133	48B48207	150
OLYMPIC	7-526		RF-770	100
	7-622		RF-849	150
	7-638		RF-849	150
	9-542		RF-1744	75
PACKARD-BELL	471		72001	75
PHILCO	49 Series	121	34-8003	75
			34-8003-2	150
	50 Series	121-122 & 123	34-8003-2	150
			34-8003	75
	51 Series	121 & 122	34-8003	75
			34-8003-1	100
PILOT	T-570		110-306	150
	T-573		110-306	150
	T-601		110-318	100
RAULAND	2200 Series		JR-0013	100
RCA VICTOR	BX Series	RC Series	B940267-1	75
	9BX56	RC1068	B940267-1	75
	9X7	RC-1057B	B940267	150
	45EY3	RS-136A	B940267-3	65
	66BX	RC-1044	B940267-1	75
	77U	RC-1057A	B940267	150
REGAL	FM78			150
	747			150
	777			75
	1877		175-1	75
	1878		175-1	75
REMLER	5300 Series		L30255	75
SENTINEL	1U-316		57E1-4 or 5	75
	286PR		57E1-4 or 5	75
	302 Series		57E1	100
	316 Series		57E1-4 or 5	75
SETCHELL-CARLSON	447		SR-1	75
	449		SR-1	75
	458RD		SR-1	100
	469		SR-1	100
SIGNAL	341A			75
	341T			75
SILVERTONE	8020	132.841	N20207-3	75
	8021	132.868	N20207-3	75
	8168	109.638	DA60256	75
	9161	548.35-8	1633	75
	9270	547.245	V6588-1	75
	9280	528.168	T-83-642	65

Manufacturer	Manufacturer's Model No.	Manufacturer's Chassis No.	Sarkes Tarzian	
			Manufacturer's Part No.	Model No.
SONORA.....	WDU-249.....		N5885.....	75
	WLRU Series.....		N6579.....	75
	402F.....		N6579.....	75
SPARTON.....	5-07-PA.....		PA-4202.....	75
	150-1-2-5.....		PA-4208.....	75
STEWART-WARNER.....	AT Series.....	9026 Series	504972.....	150
	B72CRI.....	9038B.....	504972.....	150
STROMBERG-CARLSON.....	1200.....		162034.....	75
	1202.....		162034.....	75
	1204 Series.....	112021.....	162058.....	150
	1400.....	112046.....	162034.....	75
	1500.....	112105.....	162034.....	75
TELE-TONE.....	145.....	R.....	SR-1.....	100
	152.....	R.....	SR-1.....	100
TEMPLE.....	G-410.....		ED-1.....	75
	G-415.....		ED-1.....	75
	G-521.....			100
	G725.....		ED-2.....	150
	H-415.....		ED-1.....	75
	H-521.....			75
TRAV-LER.....	5000 Series.....		SR-1.....	100
TRUETONE.....	D-2919.....		A-21J-12775.....	100
	D-3630.....		93A1-2.....	100
	D-3720.....		A83-391.....	75
	D-3721.....		A83-391.....	75
	D-3722.....			75
	D-3811.....	114BXH.....	A83-391.....	75
	D-3910.....		A83-568.....	75
WESTINGHOUSE.....	H148.....		V4115.....	75
	H165.....		V4115.....	75
	H185.....		V4115.....	75
	H195.....		V4115.....	75
	H202.....	V2128-2.....	V6070.....	100
	H204.....	V2128-2.....	V6070.....	100
	H-302P5.....	V2151-1.....	V-6658-1.....	75
	H-303P4.....	V2153.....	V-9446-1.....	75
	H-304P4.....	V2153.....	V-9446-1.....	75
	ZENITH.....	G-402.....	4G41.....	212-10.....
G-500.....		5G40.....	212-5 or 9.....	75
G503.....		5G41.....	212-10.....	65
G723.....		7G04.....	212-7.....	100
G-724.....		7G02.....	212-7.....	100
G-725.....		7G01.....	212-7.....	100
H-723.....		7H04.....	212-7.....	100
H-724.....		7H02.....	212-7.....	100
H-705.....		7G01Z.....	212-7.....	100
4G800.....		4E41.....	212-4.....	75
4G903.....		4F40.....	212-5.....	65
5G003Z.....		5C40Z.....	212-2.....	75
6G801.....		6E40.....	212-3.....	100
7H820.....		7E01.....	212-3 or 4.....	100
7H822.....		7E02.....	212-3 or 4.....	100
7H918.....		7F03.....	212-7.....	100
7H920.....		7F01.....	212-3.....	100
7H921.....		7F04.....	212-3.....	100
7H922.....		7F02.....	212-7.....	100

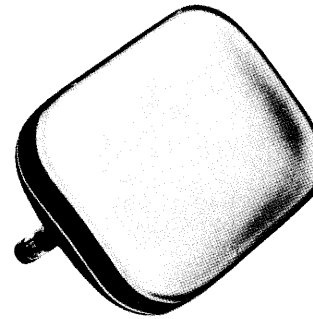

CATHODE RAY & RECEIVING TUBES

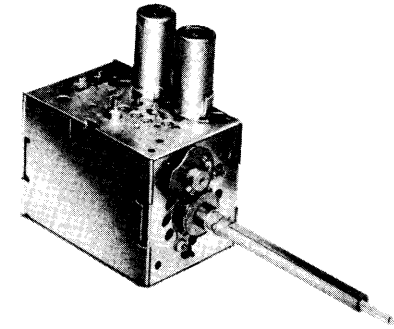

TELEVISION TUNERS

WTTV

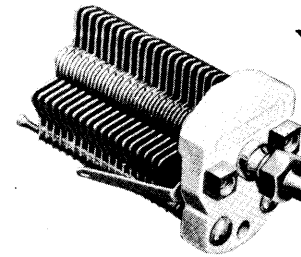

AIR TRIMMERS

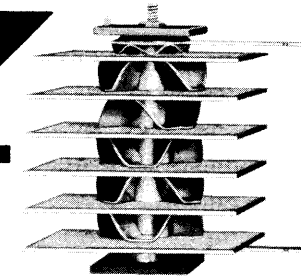

SELENIUM RECTIFIERS

WTTS

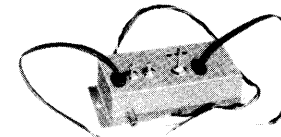

SINGLE BAND UHF TRANSLATOR

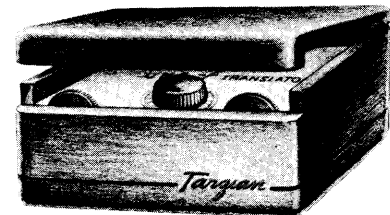
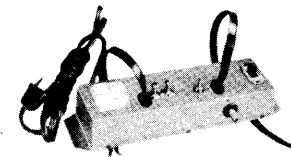

FULL RANGE UHF TRANSLATOR

