

Principles of
AERONAUTICAL
RADIO ENGINEERING

BY

P. C. SANDRETTO

*Superintendent of the Communications Laboratory
United Air Lines Transport Corporation*

FIRST EDITION
SECOND IMPRESSION

McGRAW-HILL BOOK COMPANY, INC.
NEW YORK AND LONDON
1942

PRINCIPLES OF AERONAUTICAL RADIO ENGINEERING

COPYRIGHT, 1942, BY THE
MCGRAW-HILL BOOK COMPANY, INC.

PRINTED IN THE UNITED STATES OF AMERICA

*All rights reserved. This book, or
parts thereof, may not be reproduced
in any form without permission of
the publishers.*

THE MAPLE PRESS COMPANY, YORK, PA.

PREFACE

Since this book is believed to be the first purporting to discuss the principles of aeronautical radio engineering, it seems mandatory that this subject be defined. Shortly after some enterprising individuals began to consider the airplane as the basis for a different transportation system, it was realized that the means that had been employed for *navigating* between fixed terminals were not applicable to *avigating* between these terminals, particularly as it was desired that the airplane complete its journey in all types of weather. It likewise became apparent that radio was the only medium that could be employed to perform this task successfully. Radio-engineering principles were extended to include solutions to the peculiar problems of transportation by air, and it is this extension that I have chosen to call the "Principles of Aeronautical Radio Engineering."

The word "extension" implies a starting point; therefore it is necessary to explain how I determined the point where ordinary radio engineering ends and aeronautical radio engineering begins. Of course, there is no such well-defined point. It was necessary to cover many subjects that, if removed from the covers of this book, would be without characteristics to distinguish them from other types of radio engineering. Although attempting to adhere strictly to aircraft applications, I have discussed in greater detail the fundamentals of those subjects that I have heard most frequently debated by practicing aeronautical radio engineers.

Since this book is intended chiefly to cover the extension, no attempt is made to go into the first principles of radio engineering, much less the fundamentals of electrical engineering. It is assumed that the reader has some preliminary knowledge of radio and at least understands the terms used in describing the characteristics of the apparatus. There are many fine books available on the subject of radio and communications engineering written by authors far more capable than I; so if the reader lacks this essential knowledge, he should go to them before he attempts to read this book.

To the practical man, this book may seem too mathematical, but the mathematician will recognize the limited depth of my derivations. The derivations of only those formulas thought to be particularly significant in this work are presented. It was thought that these derivations would be useful to the designers of equipment, but that the subject would not be completely nebulous to one who does not understand them. For the serious mathematician, references are given which will serve to allow the mathematical formulas to be traced to their sources.

In order to understand fully the application of the principles set forth, it is necessary that the reasons for their developments be known; therefore, the book is sprinkled with a liberal treatment of the history and philosophy behind each development.

Although the major interest today is centered on military aviation, this book is written chiefly from the standpoint of continental commercial airline operation. It is believed that the same principles hold in both fields, but that tactical requirements demand further extensions. Although the information contained in this book may not be sufficient for military use, it should, however, serve the purpose for which it was written, that is, as a basis to which additions can be made by the student.

In some cases it will be found that after describing a problem, the solution is covered in a too offhand manner. For this I apologize. It must be remembered that much of this subject matter is new, and although solutions have been worked out, they often have not been thoroughly tested, and it is therefore not possible to give too many details. The factor of secrecy has come into many of the discussions. For both commercial and military reasons, some of the facts cannot be published.

As to the source of my material, some of the first work in this field was done by the United States Army Aircraft Radio Laboratories and by the National Bureau of Standards. Workers in these laboratories published many papers with accounts of their work. From these papers certain information was obtained. The Communications Laboratory of United Air Lines Transport Corporation was organized in 1929 for the purpose of working on the application of radio equipment to aircraft and the associated problems and has worked diligently in this field ever since. The entire files of this laboratory were made available to me. The work that had been handled by the Bureau of Standards was later

transferred to the Radio Development Section of the Bureau of Air Commerce (now the Civil Aeronautics Administration), and this group has been responsible for all the developments of ground-station facilities. Descriptions of many of their researches have been published in Technical Development Reports which the public is allowed to reproduce. Also the Bell Telephone Laboratories, associated with the Western Electric Company, the Bendix Radio Corporation, the International Telephone and Radio Manufacturing Company, and the Radio Corporation of America must be mentioned as having contributed significantly to the development of aeronautical radio apparatus and thus to this book. To all these organizations I wish to express my appreciation, and to the Institute of Radio Engineers, the American Institute of Electrical Engineers, the Franklin Institute, the Institution of Electrical Engineers, and the National Advisory Committee for Aeronautics, which allowed me to reproduce some of the material that had appeared in their publications.

In particular I wish to express my thanks to A. E. Harrison, formerly of Aeronautical Radio, Inc., for his review of Chap. II; to Andrew Alford of the International Telephone and Radio Manufacturing Company for his review of Chap. III; to R. R. Brunner of the Bendix Radio Corporation for his review of Chap. IV; to W. E. Jackson, chief of the Development Section of the Civil Aeronautical Administration, for his review of Chap. VI; to F. C. McMullen of the Western Electric Company for his review of the section on the WECO altimeter in Chap. VII; to Harry Diamond of the Bureau of Standards for his review of Chap. VIII; to Charles R. Burroughs for his review of the section on the calculation of field strength in Chap. IX; to A. F. Trumbull, superintendent of Aircraft Radio Maintenance of United Air Lines, for his review of Chaps. XI and XII; to N. E. Klein and other of my colleagues of the United Air Lines Communications Laboratory, for their contributions; and, last but not least, to my wife for her patience in correcting the sentence structure and assistance in preparing the entire manuscript.

P. C. SANDRETTO.

Chicago, Ill.
May, 1942

CONTENTS

	PAGE
PREFACE	V

PART I

INTRODUCTION

CHAPTER		
I.	APPLICATION OF RADIO TO AERONAUTICS.	1
	Radio for Avigation	3
	Radio for Communication	5
	Installation of Radio in Aircraft.	7
	Aircraft Systems	8
	General Equipment Design Considerations.	9
	Service Procedure for Aircraft Radio.	19
	Service Organizations	19
	Considerations in Ground-station Installations	22
	Characteristics of Ground-station Installations	22

PART II

AVIGATION

II.	THE RADIO RANGE	24
	Field Pattern of a Loop	24
	Proof of Equation.	26
	The Radio Range.	29
	Range Characteristics	30
	The United States Range System.	31
	Characteristics of Range Loops.	31
	Course Rotation	36
	Course Shifting and Bending.	40
	Night Effect	43
	The <i>TL</i> Range	45
	Characteristics of Range Towers	46
	Design of Output Circuits for the <i>TL</i> Range	48
	The Simultaneous Radio Range.	53
	The Simultaneous Range Transmitter	56
	Visual Radio Range.	56
	Geographical Coverage of Radio Ranges.	59
	The Range Receiver.	62
	Range-receiver Antenna	66
III.	THE ULTRA-HIGH-FREQUENCY RADIO RANGE	72
	Bent Courses	72
	Multiple Courses	75

CHAPTER	PAGE
Experimental Results	78
Effects of Wave Polarization	80
The Simple Ultra-high-frequency Radio Range	83
The Alford Loop	85
Aural Range with Loop Array	87
Visual Two-course Range	90
The Omnidirectional Range	92
Geographical Coverage of Ultra-high-frequency Radio Ranges	95
Aircraft Ultra-high-frequency Range Receiver	97
Ultra-high-frequency Range Receiving Antenna	100
IV. AIRCRAFT DIRECTION FINDERS	106
Precipitation Static	106
Cause of Precipitation Static	107
The Loop Receiving Antenna	110
Phase of the Induced Voltage	115
Unbalanced Current Effects	116
Shielded Loop Antennas	118
Voltage Output of Loop Antennas	119
Low-impedance Loops	122
The Cardioid Field Pattern	126
The Simple Direction Finder	127
Radio Compass	128
Automatic Direction Finder	131
The Busignies Automatic Direction Finder	134
Direction-finder Errors When Using Range Stations	137
Characteristics of Compass Receivers	138
Testing Radio Compasses and Direction Finders	140
Aircraft Installations and Quadrantal Errors	142
V. MARKERS	146
Cone of Silence	146
Z Marker	150
The Z Transmitter	151
Z Transmitting Antenna	152
Fan Markers	153
Fan-marker Transmitter	155
Fan-marker Antenna	156
Other Markers	156
High-frequency Marker Receiving Antenna	157
Marker Receiver	160
Microwave Markers	164
Improved Z Marker	167
VI. INSTRUMENT LANDING	168
Principles of All Instrument-landing Systems	169
Bureau of Standards Glide Path	169
The Bureau of Standards System	174
United-Bendix System	176

CONTENTS

xi

CHAPTER	PAGE
Controlling the Shape of the Isopotential Glide Path	184
The Civil Aeronautics-International Telephone Glide Path	186
The CAA-M.I.T. Instrument-landing Development	192
Other Systems	196
 VII. ABSOLUTE ALTIMETERS	 198
Principle of the Sonic Altimeters	199
Sound Generators	199
Sound Detector	201
Distance Indicators	202
Errors in Sonic Altimeters	205
Limitations of Sonic Altimeters	206
Performance of Sonic Altimeters	207
Commercial Availability	208
The Capacity Altimeter	208
Magnitude of Capacity	209
The Gunn Altimeter	209
Results of Capacity Altimeter Development	211
Radio Altimeters	211
Early Radio Altimeters	211
The Alexanderson Altimeter	212
History of the Western Electric Radio Altimeter	214
Principle of Weeco Altimeter	215
The Weeco Altimeter	217
 VIII. DIRECTION FINDING FROM GROUND STATIONS	 225
Characteristics of Waves Received from the Ionosphere	227
Effect of Horizontal Polarization on Loop Direction Finders	234
The Adcock Direction Finder	236
Polarization Errors in Adcock Direction Finders	240
The Spaced-loop Direction Finder	242
Effect of Abnormal Polarization on the Spaced Loop	243
Corrections for Other Ionosphere-propagated Wave Char- acteristics	244
Unbalanced Current Effects	246
Diversity Errors	246
Minimum Signal-strength Error	249
Terrain Errors	250
Instrument Errors	252
Medium-high-frequency Direction Finders Used in the United States	253

PART III

COMMUNICATIONS

IX. MEDIUM-HIGH-FREQUENCY COMMUNICATION	257
Calculating the Strength of Airplane Signals	259
Characteristics of Airplane Signals	264

CHAPTER		PAGE
	Characteristics of the Ionosphere	266
	The Ionosphere in Aircraft Communications	269
	Predicting the Behavior of An Ionosphere-propagated Wave	270
	The Aircraft Transmitting Antenna	275
	Calculating the Characteristics of Aircraft Transmitting Antennas	277
	Electrical Characteristics of Aircraft Transmitting Antennas	281
	Space Patterns of Aircraft Communications Antennas	283
	Aircraft-transmitter Output-circuit Design	285
	Aircraft-transmitter Frequency-changing Methods	289
	Other Considerations in Aircraft-transmitter Design	290
	The Aircraft Communications Receiver	291
	Characteristics of Ground-station Transmitters	293
	The Ground-station Receiver	298
	Ground-station Antennas	300
X.	ULTRA-HIGH-FREQUENCY COMMUNICATION	307
	Wave Polarization for Communications Use	309
	Type of Modulation	309
	Ultra-high-frequency Airplane Communications Antenna	310
	Antenna Space Patterns	313
	Other Transmission Anomalies	317
	The Airplane Transmitter	320
	The Airplane Receiver	321
	The Ground-station Transmitter	323
	The Ground-station Receiver	324
	Ground-station Antennas	324
	Microwave Communication	326

PART IV

ACCESSORIES

XI.	AIRCRAFT POWER SUPPLY SYSTEMS	328
	Growth of Aircraft Electrical Demand	328
	Electricity on a Modern Airplane	329
	The Common Electrical System	330
	Optimum Voltage for Aircraft	337
	Alternating Current for Aircraft	340
	Variable-frequency Alternating-current Systems	344
XII.	CONSIDERATIONS IN AERONAUTICAL RADIO SYSTEMS DESIGN	348
	Aircraft Noise Suppression	349
	Antenna Facilities for Aircraft	352
	Operating the Aircraft Transmitter	357
	Audio-output Systems	366
	Interphone in the Airplane	373

CONTENTS

xiii

CHAPTER		PAGE
	Aircraft-radio Power Systems	379
	Aircraft Control Units	382
	Systems for Small Ground Stations	384
	Systems at Major Air Terminals	386
	Microphones	390
	Headphones	392

APPENDIX

MECHANICAL REQUIREMENTS FOR AIRCRAFT RADIO EQUIPMENT.	395
INDEX.	407

PRINCIPLES OF AERONAUTICAL RADIO ENGINEERING

CHAPTER I

APPLICATION OF RADIO TO AERONAUTICS

The pilot of a modern air transport would no more consider taking off for a distant destination without his full complement of radio equipment in working order than he would consider taking off with only one half of the main engines in operation. This fact can be readily understood by comparing the flight with an automobile trip through a portion of the country having no highways and where no information of the terrain or weather ahead is available, for to the airplane the radio system is both a highway and a source of information and advice. But what of the men who flew before the advent of aeronautical radio? How did they reach their destinations? They flew close to the ground and followed landmarks. Often, however, they flew into fog conditions and met disaster. A transport system must not be hampered by weather and, hence, must have a road that is open, available, and safe under all conditions.

Those who have not had the occasion to consider navigational problems may wonder why the magnetic compass is not a satisfactory and sufficient avigational device. A magnetic compass points only to the north and south magnetic poles and, therefore, indicates only the direction in which an airplane is *heading*. Airplanes in New York and California may have the same headings indicated on their compasses; therefore, these devices do not indicate position. It is true, of course, that if all the forces acting on an airplane were known, it would be possible to hold it to any course desired, but despite the efficient government weather-bureau measurements and the reports of previous airplanes, the magnitude and direction of the winds are seldom known with sufficient accuracy to permit precise long-range flying.

2 PRINCIPLES OF AERONAUTICAL RADIO ENGINEERING

In Fig. 1 is shown an airplane headed due west, leaving terminal *T* for a town *C* located 500 miles from *T*. The magnetic compass in this airplane would indicate 270 deg. If it is assumed that the air speed of the airplane is 180 m.p.h. and that there

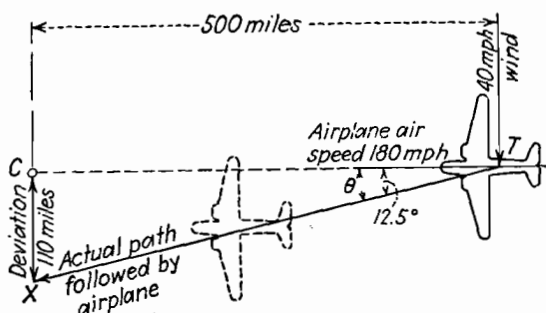

FIG. 1.—Effect of cross wind on the course flown by an airplane.

is a cross wind of 40 m.p.h. from the north, then by using the laws of force and trigonometry, the following calculation may be made:

$$\tan \theta = \frac{40}{180} = 0.22$$

$$\theta = 12.5^\circ$$

If the deviation of the airplane from its true course is expressed by *D* and the airplane retains its 270-deg. heading, then

$$\frac{D}{500} = 0.22$$

$$D = 110 \text{ miles}$$

That is, the airplane will actually arrive at a point 110 miles south of the desired destination. If the ground had been visible or radio means had been employed to tell the pilot the path he was actually traveling, he would have made a computation allowing for the wind. This procedure is used as an avigational method, but without the sight of land or radio facilities the calculations cannot be trusted. The method without visual or radio check is known as "dead reckoning," and the statement "he dead-reckoned himself into a mountain" was heard too often in the preradio days of air transportation.

Although all aeronautical radio has as its general purpose the promotion of reliability and safety of air travel, its two main

uses may be classified under the general headings of Avigation and Communication.

Radio for Avigation.—The avigation problem simply means “how to get there”; therefore, radio used for this purpose is the most important on the aircraft. The majority of the radio units on an airplane are used for avigational purposes.

Although the airplane adds another dimension, the problem of how to get there by air travel may in many respects be compared with the analogous problem of land travel.

In beginning a trip by land, a road of some type is required. The pioneers who traveled west secured Indians to show them the trails. They could have resorted to celestial navigation, perhaps, but a trail of some sort is the easier mode of travel. In American aviation, the first radio was used in just that manner—to build a road. This radio road (range or beacon, as it is called) is discussed at length in the second and third chapters.

If there is a road that can be traveled, confusion can still exist unless there are means of identifying towns or recognizing destinations. The radio range provides the equivalent of radio markers, but a positive intersection and terminal marker did not become common on the United States airways until Jan. 1, 1938. This important facility is described in Chap. V and is called simply a *marker*.

A road and proper signposts constitute the fundamentals of a travel system, but in aviation it is necessary to furnish additional facilities. If bearings can be taken on familiar landmarks, it is possible to determine the progress toward the destination. These bearings also make it possible to leave the road temporarily and travel across fields. A pilot must time his progress accurately and detour storm areas directly in the path of his normal airway. For this purpose, the radio direction finder discussed in Chap. IV is used. Also with this direction finder he can quickly determine his location if he must leave the range and circle while waiting for clearance which permits him to come into the airport.

In air transportation it is necessary to have a means for determining a safe path of travel through the vertical dimension. This, of course, is not a problem in land travel. The instrument-landing systems of Chap. VI and the altimeter of Chap. VII are for this purpose.

4 PRINCIPLES OF AERONAUTICAL RADIO ENGINEERING

Inasmuch as all the preceding functions are performed by radio, its importance to air travel can be readily understood. Because equipment units for all the foregoing purposes, together

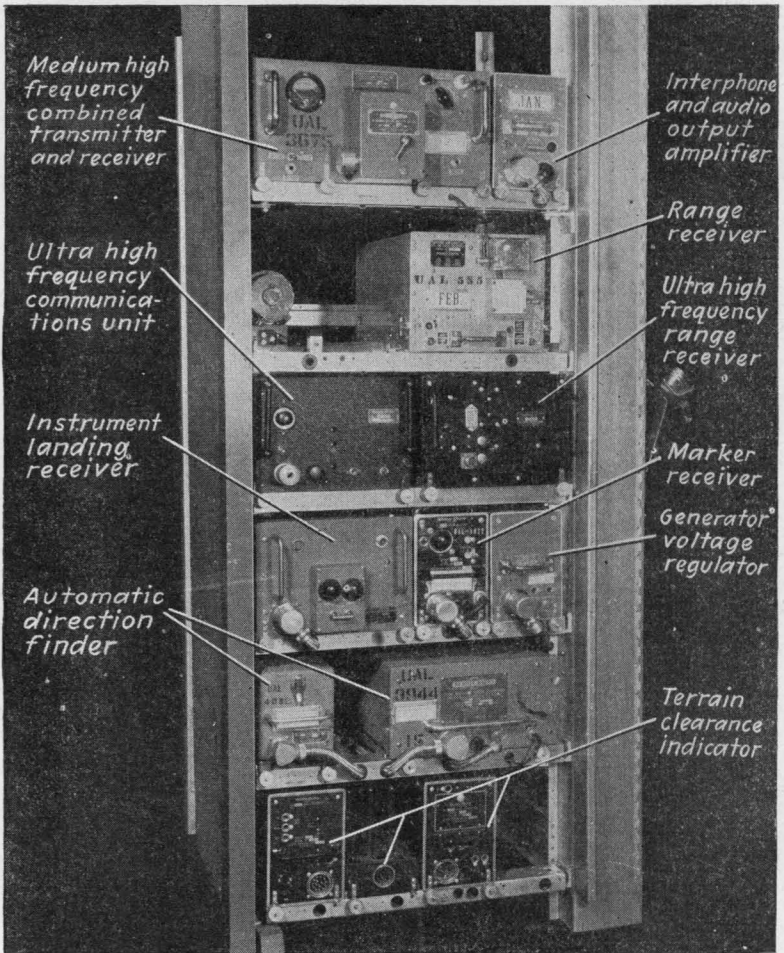

FIG. 2.—Aircraft radio equipment. Not all of the units shown in the aircraft mounting rack are in general use. (Courtesy of United Air Lines.)

with necessary spare units for guarding against failure, must be provided, it is evident that the number of radio sets required for avigational purposes alone will not be small. A full complement of radio equipment for a transport airplane is shown in Fig. 2.

Radio for Communication.—Shortly after the first piece of radio was installed on the airplane for avigational purposes, a radio receiver and transmitter were added to make communication possible between the aircraft and the ground. Why this was the next step may be questioned. The answer lies in the method of flying in use at that time. There were only a few radio ranges, and it was not possible to base a flight plan entirely on these. Invariably the pilot flew under the overcast, or if he went “on top” to fly by referring to mountain peak landmarks, he expected to find a clear weather condition or an excellent ceiling at his terminal. He often landed his airplane in any available tract of land and waited for the weather to clear. A communication system, then, was installed, not primarily to allow the pilot to discuss weather with ground personnel and ask for help when making an emergency landing, but also to give reports to the groundmen to enable them to know all was well or that they should start out in search of the missing airplane. Those days have passed, however, and communication between the airplane and the ground serves many new purposes. Some of these are as follows:

1. Between pilot and dispatcher to learn weather trends

2. Between pilot and ground personnel to learn when the airport is clear for landing and advise those who control the airport of time of arrival

3. Between pilot and ground personnel to learn of airport conditions with respect to the prevailing traffic

4. Between pilots of airplanes as a collision-prevention means

It can be seen that these problems relate to talking and are therefore different from those described under Avigation. These must be met with an entirely different set of apparatus. Communications equipment is discussed in detail in Chaps. IX and X.

In the United States, all communication between the ground and the airplanes of the continental airlines is done by the use of telephony. The ground-station communication facilities are all owned by the aircraft operator, as contrasted with the ground-station avigation facilities, which are owned by the government.

A question often asked is, “Why telephony instead of telegraphy?” In the early days of air transportation all the airplanes were flown by a single pilot, and the difficulty of manipulating

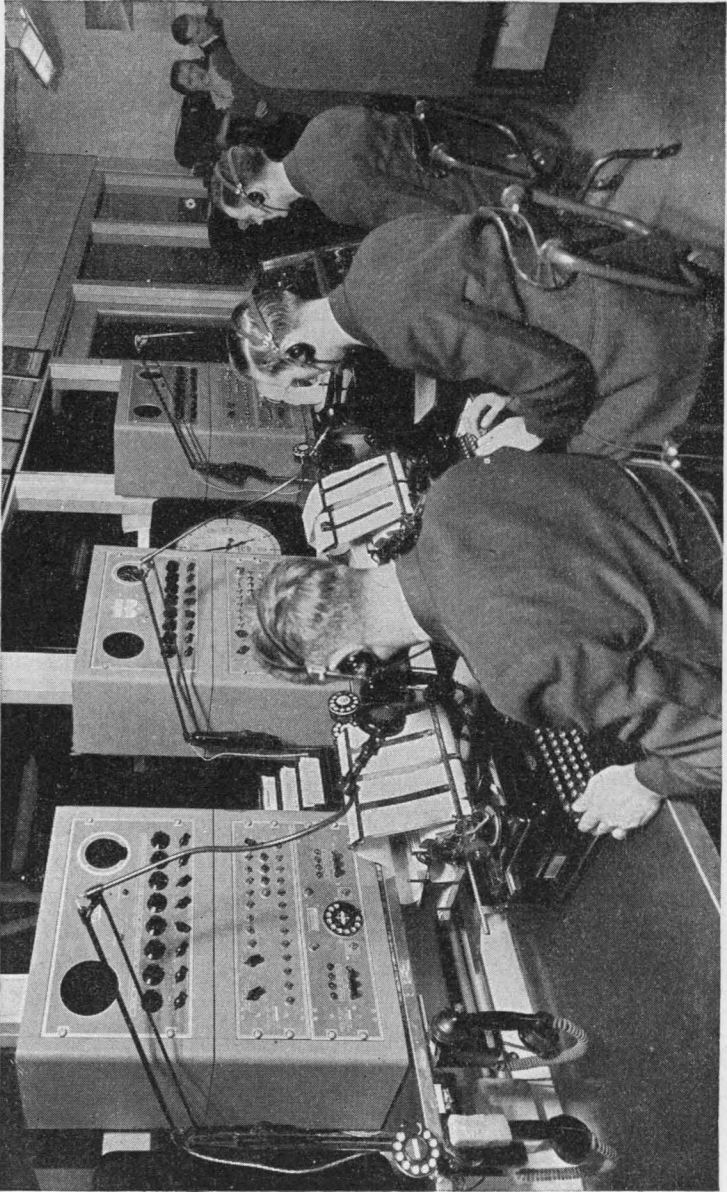

Fig. 3.—An airlines communication station. (Courtesy of United Air Lines.)

a telegraph key with one hand while flying an airplane in rough weather with the other is clearly evident. As the airplanes became larger, another pilot was added, and the question arose, "Why not use a radio operator?" The answer is that the information coming over the communication system is for the pilot, and any intermediary between him and this source of information defeats the purpose for which the equipment was installed.

The telegraph argument centers around the statement that telegraphy is more readily understood through static. This may be true under certain types of static conditions, but tests made under "crash" type static conditions have led to contradictory results. By crash-type static is meant that static which occurs as bursts having irregular periodicity. Tests have shown that between bursts it was possible to understand several words with telephony but only a few characters with telegraphy. During the bursts, neither telegraphy nor telephony can be understood; therefore, telephony yielded the greatest amount of information in a given period of time. An airline radio-telephony ground station is shown in Fig. 3.

Installation of Radio in Aircraft.—By the late fall of 1929, there was installed in the United States a line of radio ranges extending from New Jersey to Iowa(1).* At that time the manager of National Air Transport, the airline then operating from New Jersey to Illinois, wrote as follows in an article(2) on the subject of the facilities offered by radio in aircraft:

There is no question as to the assistance that radio can give to the air transport pilot. The problem is to insure against failure of the system. A catastrophe may be easily caused if the pilot relies on radio at a future instant and it fails him for one cause or another. It would be far better to have had no radio at all.

The article further states that the radio equipment was far too delicate and fragile. This quotation accurately expressed the problem that was involved. Here was a phenomenon that could provide huge benefits if the apparatus required for its production and control were only capable of withstanding the peculiar service to which it had to be subjected. The answer was not a simple one but rather a matter of learning the problems and then working out the necessary solutions. The entire prob-

* Throughout this book numerals enclosed in parentheses are used to indicate source of material as listed in the bibliography at the end of each chapter.

lem is not yet solved, and the perfect solution will probably never be fully attained, but each year has seen some new advances. The difficulty with the earlier equipment was that it had been designed to perform a task for a different set of conditions. The establishment of the aircraft point of view is vital to the design of satisfactory equipment.

Equipment still fails today, as does anything made by man, but these failures are few and average not more than five for each 100,000 miles flown. When these failures do occur, they do not cause the calamity predicted by the airline manager because there are a number of other units ready to take up the task. In each commercial airplane today about eight radio units are installed, but more are being added as soon as they can be manufactured. Each unit is designed to perform a new function—a function that will remedy a weakness of another unit.

Aircraft Systems.—This important phase of aircraft-radio installation will be discussed in detail in Chap. XII. It is mentioned here, by way of introduction, as an important consideration in aircraft radio installation.

Radio units can be set up individually in a laboratory and it can be shown that they are operating properly; yet they may be totally useless in an airplane. The reason for this is that a radio system is necessary in an airplane, but radio units *as such* do not have any significance. This point may be hard to understand, and in the past manufacturers have made equipment that did not sell because they did not understand the principle just described. The equipment they manufactured worked well in their laboratories, but it did not *fit* into the pattern of the aircraft radio system desired by air-transport operators.

By an aircraft radio system is meant a coordinated set of radio mechanisms terminating in a few controls and indicators. When a flight officer wants *certain information* necessary to enable him to continue his flight, he manipulates control *A* and the answer he desires must instantly appear on indicator *B*. The fact that a piece of radio equipment does any of a number of other clever things originated by the imagination of some ingenious engineer is of no interest to the flight officer. Additional controls hamper operations and are aggravating, too many indicators are annoying, and having various unattached radio phenomena occur which are disassociated with the pilot's wants

of the moment is distracting when he is attempting a particular "tough" weather manipulation.

The controls required are for volume, frequency, and facilities, and the indicators are headphones, lights, and meters. The interconnection of the various radio units must be carefully worked out as well as the design of each control knob and its location in order that an aircraft radio installation may be successful. Tuning or frequency-selection controls must be made to give the desired frequency in a minimum length of time, otherwise they are unsuccessful. Switching of any type must be simple. To be successful, the final arrangement must be the answer to the problem of airplane operation rather than a solution to the individual radio-unit operation.

General Equipment Design Considerations.—Because of the importance of radio to aircraft operation, it is necessary that radio units be designed in such a manner that they will successfully withstand service without failing. Here it is necessary to define what the air-transport operators mean by service. Certain industries require that a piece of equipment be so constructed that it will last for an indefinite period. The aeronautical field recognizes that technically there will be advances, and hence it is not interested in equipment that will last forever. The equipment desired is that which will not stop performing when in use, even though certain portions of it must be replaced at periodic intervals. Many equipment manufacturers who have not previously served the aeronautical industry fail to differentiate between equipment the component parts of which will not wear out for a long period of time and that which will not fail in use. The former type is invariably heavy, and this is undesirable. Because of these requirements, the units must be sturdily constructed, but *sturdy construction* does not mean *heavy construction*; for it is an essential requirement of aircraft equipment that its weight shall be held to a minimum. The same principles used in constructing the airplane should be used in constructing the chassis of airplane radio equipment. Instead of heavy-gauge material, light gauge with webs and turned edges should be used to give strength. Where parts are subject to wear (such as slides) reinforcing should be provided in the form of stainless-steel angles rather than making the entire structure of heavier metal.

Not only in the design of the structure of the aeronautical radio units but also in circuits, it is important to depart from conventional design and use ingenuity rather than brute force. Circuits should be designed so that they are highly efficient and stable. Necessary adjustments should be kept to a minimum, for it should be borne in mind that the adjustment designed *out* of a radio circuit is the adjustment that will never be incorrectly made.

All parts should be *readily accessible*. A part that fails may be excusable, but a part that cannot be readily serviced when it has failed is not excusable. It should be possible to replace any part in a radio unit in not more than 10 min. Preferably, no special tools should be required. All radio units should be so constructed that they can be easily removed from the airplane for service and replacement. All connections should be made by plugs which can be easily detached.

Shock mounting in the past consisted of certain rubber shock absorbers mounted to the radio units; however, the trend is toward the use of shock-mounted shelves permanently installed in the airplane. The apparatus units in this case are not fitted with shock mounts but rely on those in the airplane.

Apparatus in service must be continually removed and installed, and because of the narrow companionways through which servicemen must pass to reach this equipment, only one man can conveniently handle a radio unit. This means that every effort should be made to limit the weight of a piece of equipment to 50 lb. A further requirement, because of the conditions listed above, is that effective carrying handles should be provided.

For the purpose of consolidated purchasing, the airline companies have formulated a set of mechanical specifications. These are found in the Appendix. The requirements specified may well be followed when designing aircraft radio equipment because their formulation was the result of field equipment experience rather than a conclusion born of theoretical consideration.

In the United States, the Civil Aeronautics Administration has formulated a series of tests to which radio equipment must be subjected before it is approved for use on the airplanes of air carriers. These tests, which were designed to determine the ability of radio equipment to withstand aircraft service, are not

set up to simulate field conditions but are much more severe. They are intended to serve as accelerated life tests and be equivalent to about 5 years of service.

Humidity Test.—The humidity test is specified as follows:

The unit shall remain for a period of 48 hours in an atmosphere of clear vapor maintained at not less than 95% humidity and at a temperature of 50 degrees centigrade. (Permissible tolerance of relative humidity, 5% plus or minus; permissible tolerance of temperature, 3 degrees.) The percentage of humidity and the time element involved may be less than the maximum specified above if, in the opinion of the Inspector, the design of the unit is such that any inherent defects will be disclosed at a lower percentage of humidity or within a shorter period of time. Wherever possible the unit shall be operated at intervals specified by the Inspector during the actual humidity test to determine the effects of such tests. When measurements are not being taken, the unit must not be in the standby or operating positions. Upon completion of the humidity exposure, the unit shall be tested and such pertinent information as required by the Inspector for purposes of comparison shall be made. The sensitivity performance of receivers, radio compasses, receiving equipment, and power output of transmitting equipment after the test shall not be below the following value at the periods stated:

After 30 minutes warm up period, the sensitivity shall have returned to a value of 4 to 1 or better as compared to measurements taken prior to the test, and at the end of 4 hours of operation, substantially complete recovery must be obtained. At the end of 15 minutes, transmitters and transmitting equipment shall return to within 75% of normal power output and at the end of 4 hours recovery shall be substantially complete.

Upon completion of the humidity exposure, an inspection of the equipment shall disclose no evidence of corrosion or other condition, the presence of which, or the continuance of which, will lower the performance of the unit below the minimum necessary for the service intended.

This humidity test, besides discovering those parts which are susceptible to corrosion, uncovers certain electrical weaknesses. Insulation on certain wire becomes conductive when subjected to moisture, and its resistance is lowered. When this wire is used in high-impedance circuits (such as automatic gain-control circuits), the lowered insulation resistance serves as a partial short circuit and so decreases the value of the voltage

delivered at the terminals of these wires. Moistureproof wire is not difficult to secure. Wire that has enamel or rubber covering next to the copper, or an impregnated cotton insulation is satisfactory. On the other hand, there are many wires on the market that will not withstand the moisture test. Before using a wire, the moisture-resistance properties of which are not known, it is wise to test the wire by immersion in water followed by a resistance measurement. This test will give data indicative of the results that may be expected with the CAA test.

Coils often lose Q (ratio of reactance to resistance) in the humidity, thereby reducing the gain of receivers. This often occurs even though the coil has been impregnated. Certain impregnating compounds are very susceptible to moisture. The various wax compounds are usually satisfactory.

Moisture affects the surfaces of dielectrics to reduce the resistance between two conductors mounted on the dielectric. If the dielectric is in a transmitter, the current passed between the conductors will cause heating, leading to arc-overs. Dielectrics so affected are chiefly of the phenolic family. This difficulty can often be corrected by impregnation in wax or certain varnishes. Ceramic and glass dielectrics are but slightly affected by moisture; certain porcelains, however, are not satisfactory under moisture conditions, particularly if the voltage applied is high.

Moisture will often reduce the resistance between primary and secondary windings of power and audio transformers that are not contained in cans filled with impregnating compound.

Certain unprotected parts corrode during these humidity tests. A certain amount of this corrosion is permissible; however, most of this can be corrected by plating or painting. Gears that cannot be plated can be oiled or greased. A curve for calculating the humidity from the readings of wet- and dry-bulb thermometers is shown in Fig. 4.

Temperature Test.—The temperature test is specified as follows:

The unit shall be placed in an ambient temperature of plus 55 degrees centigrade for a period of time sufficient to permit component parts of the unit to assume that temperature. The unit shall then be operated for a period of one hour at a supply voltage 20% above that specified as normal in the case of 12 volt or 24 volt D.C. equipment, and 10% above that specified as normal in the case of 115 volt A.C. equipment. The

unit shall then be operated under the direction of the Inspector for such period as he may deem necessary at a supply voltage 10% below normal. The unit shall then be placed in an ambient temperature of minus 40 degrees centigrade for a period of time sufficient to allow the component parts to assume that temperature, after which it shall be

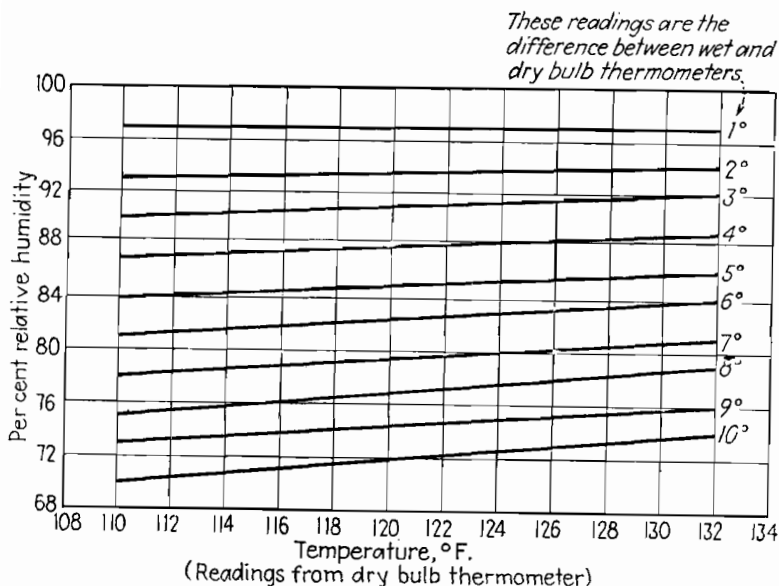

FIG. 4.—Per cent relative humidity as a function of dry-bulb-thermometer reading for various temperature differences between dry and wet bulb.

operated at supply voltages 10% below and 10% above that specified as normal for a series of operations to determine the effects of the tests.

From an electrical standpoint, the temperature test chiefly serves to vary the tuning of the various units. Change of tuning serves to decrease the sensitivity of a receiver or reduce the output of a transmitter. If the circuits are pretuned and cannot be adjusted by a cockpit tuning control, the receiver-sensitivity decrease or transmitter-power-output decrease may be excessive. Oscillators that are not controlled by a crystal or do not have special temperature-resisting design have excessive drift. If temperature effects on tuning elements are excessive, they can be corrected by condensers available on the market having the proper compensating temperature coefficient. Air condensers using bimetallic plates can be constructed to compensate for

tuning drift into other circuit elements. The subject of stable oscillators is too extensive for discussion here, and so the reader is referred to the bibliography(3) for literature on this subject.

Quartz crystals used for oscillators may become erratic at low temperatures. Unless the crystals have been cut incorrectly, hermetic sealing or heaters solve this problem.

High temperature has a destructive effect, particularly on those elements such as power transformers, tubes, and resistors which are in themselves heat-producing devices. There are several solutions to this problem. One of these consists in using elements of larger physical sizes or larger electrical ratings. Another consists of inserting baffles between the heat-producing elements and the deteriorating elements. The baffles should have a large area so that they dissipate heat. Louvers on the top and sides of apparatus cases are, of course, of apparent assistance. Forced draft can be supplied either by the use of a small motor and fan or by attaching a fan to an extended dynamotor shaft. If forced draft is used, the air intake should be equipped with a filter for removing dust. These fans should apply pressure rather than suction to the apparatus. If suction is used, dust is taken in via cracks in the apparatus, but pressure will keep this dust out.

Low temperature chiefly affects mechanical parts. The bearings of gear boxes and other parts with movable shafts seize and become inoperative. The cure consists in the use of large-tolerance shafts and special low-temperature greases.

Vibration Test.—The vibration test is specified as follows:

The unit shall be vibrated for a period of four hours at a frequency selected by the applicant, which shall fall between the range of 30 to 60 cycles per second, with an amplitude and wave form sufficient to produce a vertical acceleration of 10*g*. During this period of vibration, the unit shall be operated under the supervision of the inspector in order to detect variation in output, frequency, etc., or any other harmful effects which may be caused by the vibration. At the termination of this test, a visual inspection shall be made and shall disclose no condition produced by the vibration, the presence of or the continuance of which would be detrimental to the satisfactory performance of the unit. The unit shall then be operated over a range of frequencies varying continuously from 25 to 150 cycles per second with an amplitude which will permit the vibration to be easily felt by placing the hand on the table.

This test shall be conducted under the supervision of the Inspector and will be of sufficient duration to permit the observation of all component parts at various frequencies. During this test all component parts and structures of the unit will be observed for evidence of resonant vibration, and parts which show such tendencies shall be redesigned or remounted to eliminate the resonant condition. Where redesigning or remounting is not practical, the manufacturer shall satisfactorily demonstrate that the resonant vibration of the part will in no manner be detrimental to the performance of the unit. The use of shock mounts will not be permitted unless the use of such shock mounts form an integral part of the design of the unit, in which case, the type certificate will be abrogated if the unit is mounted without the particular shock mount which forms an integral part of the equipment. A stroboscac or stroboscopic device shall be furnished by the applicant for use in observing the unit under vibration.

From an electrical standpoint, the vibration test produces certain modulation which either makes the operation of an associated indicator erratic or creates a wavering signal in the audio output of a receiver or radio-frequency output of a transmitter. The usual source of this modulation is the variable air tuning condensers. The cure consists in more rigid mounting of the condensers. It may be necessary, however, to use a condenser with plates having a different mass or construction, that is, having a resonant frequency different from the test frequencies. Severe modulation can be caused by intermittent relay contacts. This condition may be remedied by using higher pressures at the relay contacts or shorter relay arms. A good rule to follow is to use twice the normal spring pressure if a relay is to be used for aircraft. This means, then, that relay coils for aircraft units should be designed for twice the normal ampere-turns. Certain clever designs have been evolved. One of these consists of using a knife-switch type of contact. In the other a locking mechanism is used whereby the contact arm is a portion of a simple toggle mechanism and effectively locks when it travels past a center. The mechanism follows those used in toggle switches but has a simplified form. Generally speaking, relays on aircraft have always been troublesome, and their application should be limited to those cases where they *must* be used.

A force of 10*g* is a very severe test, and unless a unit is carefully constructed many structural weaknesses may appear during the vibration test. Certain spot welds supporting large

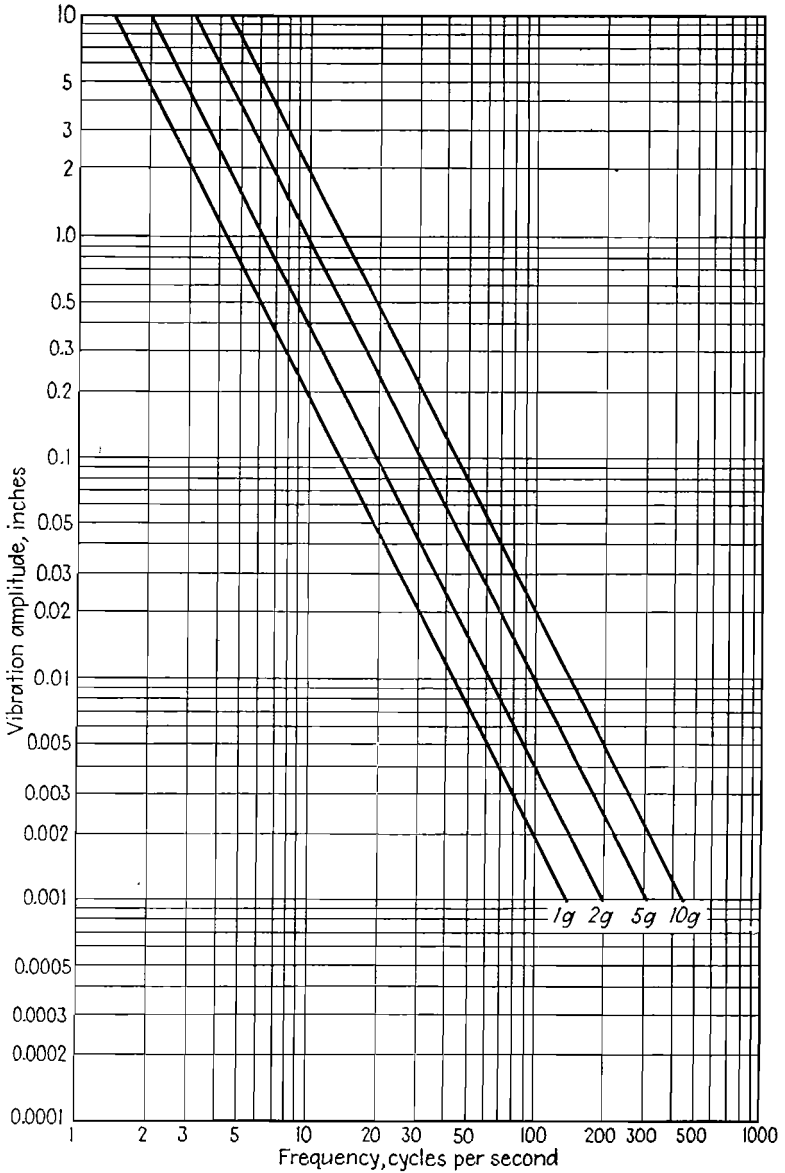

FIG. 5.—Accelerating force in g units as a function of amplitude and frequency.

masses may fail. These welds should be tested as the design of the unit progresses rather than waiting for the completed unit before making vibration tests and then learning that the entire unit must be redesigned to make it satisfactory structurally. Shock mounting will, if properly designed, greatly minimize the effects of the vibration test, but if incorrectly designed it may serve to accentuate these effects. Since these tests were designed to uncover structural weaknesses, it is strongly recommended that shock mounting should not be used in the tests. Equipment that successfully withstands vibration tests without shock mounts is preferred by equipment users because they can mount it on any rack of their own design without the necessity of having the equipment recertificated. This is a specific requirement of airline equipment. The airlines ask that their units be designed without shocks and that shocks be fitted to a detachable mounting rack. In Fig. 5 is shown a curve giving amplitude necessary for a given frequency to produce a certain acceleration.

Drop Testing.—Another test for the purpose of determining the suitability of aeronautical radio-equipment structures is the drop test specified as follows by the CAA:

At least 100 free drops from heights varying from 6 to 18 inches shall be made; no shock absorbers will be attached to the unit. If shock absorbers are incorporated in the design of the unit as an integral part of the equipment, these shock absorbers shall be removed. Commercial sponge rubber of a thickness not to exceed one inch may be interposed as a damping medium between the unit and the substantially solid platform upon which the equipment will come to rest. During this test the Inspector may require that connecting plugs and external plug-in devices be connected to determine the stability of locking devices employed thereon.

The effects, both electrical and mechanical, of the drop test on equipment are similar to those of vibration; consequently, the remarks covering equipment under vibration test also apply to those under drop tests.

Pressure Test.—As the amount of gas in a given volume is reduced, the number of collisions between ions is reduced, and the ionic path is therefore decreased. This decrease causes the conductance of the gas to increase up to the point where so much

gas is removed that too few ions are present. This means, then, that as an airplane ascends, the danger of arc-over increases. This phenomenon is shown in Fig. 6. In the early days of aircraft radio, few transmitters traveled over the Rocky Mountains and reached their destinations in an operating condition.

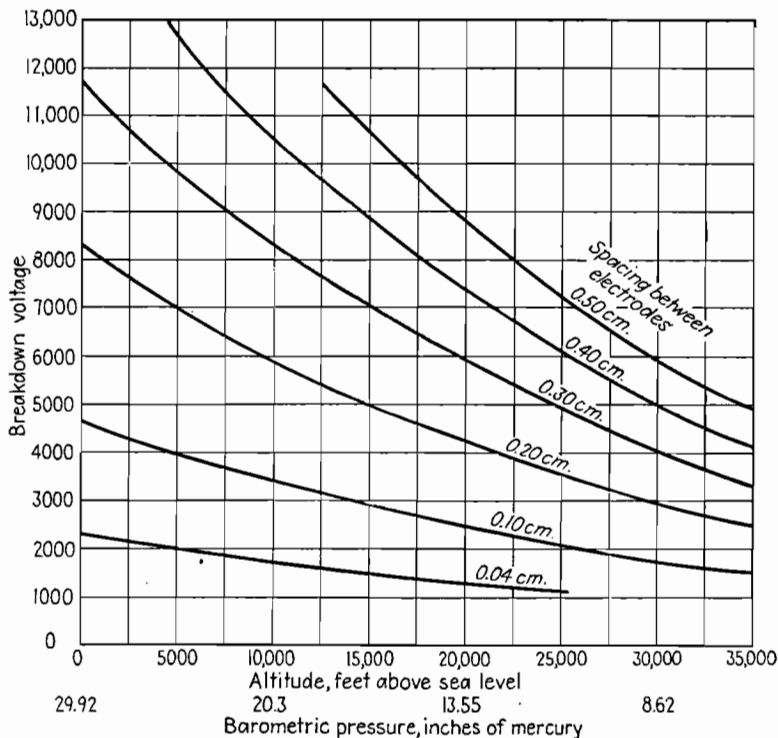

Fig. 6.—Air-gap breakdown voltage as a function of altitude for direct-current voltage applied between 2-cm. ball gaps. (Data from *Smithsonian Physical Tables*.)

Chiefly applying to transmitters and other high-voltage apparatus, the following test is specified:

The unit shall be operated in a pressure chamber under conditions of pressures ranging from 8.52 to 31 inches of mercury (sea level to 31,000 feet altitude). The period of observation at the lower pressures shall be sufficient to disclose any defects which will be aggravated by reduced pressure. The unit shall show satisfactory performance at all pressure ranges. Transmitters subjected to this test shall be tuned to their

lowest frequency and operated into the smallest antenna for which the transmitter is designed. The transmitter shall be modulated at the highest percentage of modulation for which the unit is designed.

As previously stated, this pressure test applies chiefly to high voltages, and arc-overs are its effect. The effects of high altitude may be minimized by increasing the path between high-voltage points of opposite polarity. Where a dielectric is involved, this can often be accomplished by barriers. Such a barrier is shown in Fig. 7 around the plate pin on a tube base. The curves of Fig. 6 cannot be used as an absolute criterion of design because the distance shown thereon applies to air between 2-cm. ball gaps using direct current. These curves will be greatly modified where radio frequency is used and where a dielectric other than air is present.

Service Procedure for Aircraft Radio.

The very essence of satisfactory aircraft radio operation is the constant servicing that it receives. In order to perform this service, two things are essential. One is organization and the other is procedure. The organization and procedures developed by the airlines of the United States for accomplishing this service will now be described.

Service Organizations.—Since the airplanes bearing the radio equipment travel between fixed points, it is unnecessary for the service personnel to travel, and hence bases are provided at which the equipment may be serviced. At all these places there are men capable of making the simplest of radio tests known as ingoing and outcoming checks. These checks consist of the following work:

1. Placing equipment in airplane radio racks
2. Making minor adjustments of tuning controls
3. Checking operation of all associated switches
4. Making a test transmission and listening to reception



FIG. 7.—Barrier used to increase breakdown voltage across base of transmitting tube.

5. Making oscillator tests on those radio receivers to which listening tests do not apply

6. Checking pilot log books for unfavorable comments concerning radio operation

7. Removing radio equipment from the airplane and forwarding such equipment to the service shops

Personnel used for this work need not have a high degree of radio training. Very often they have duties in connection with

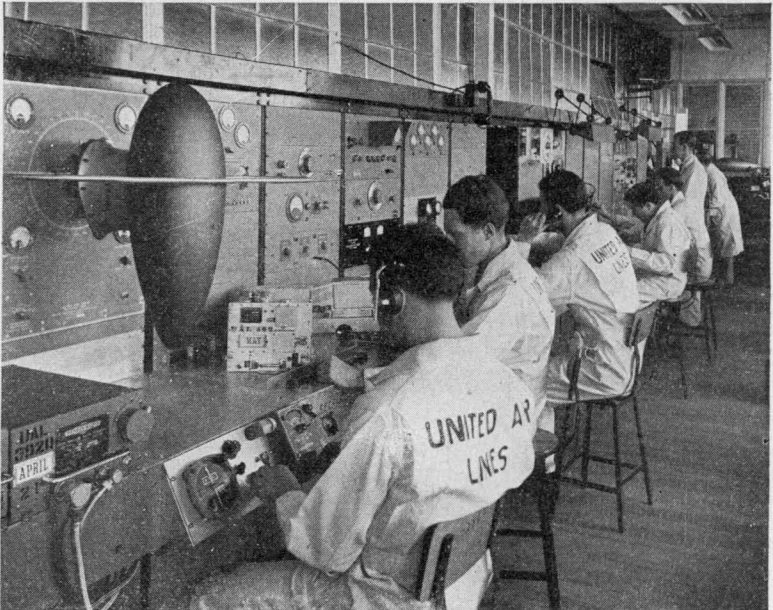

FIG. 8.—An airline radio-equipment maintenance shop. (Courtesy of United Air Lines.)

airplane service other than those concerning radio. They are charged with the repair of broken radio wiring and controls but not with the repair of any radio unit. Defective units are *replaced*. That is, they are merely removed from the radio racks, tagged with a label describing the difficulties experienced, and then forwarded to the nearest removable-unit repair base.

The removable-unit repair base employs a number of well-trained radio servicemen. These men have at least high-school and trade-school training, or the equivalent. The shops (see Fig. 8) where they are stationed invariably are equipped with

one or more screen rooms. These rooms serve to keep out noise and local transmitter interference; also they prevent the transmitter under test from interfering with the local airline communication station. In these screen rooms are the following equipment:

1. Audio oscillators
2. Signal generators
3. Artificial antennas
4. Tube testers
5. Vibrators
6. Voltmeter panels
7. Cathode-ray oscilloscopes
8. Ohmmeters
9. Capacity indicators

In short, they contain all modern test equipment.

Although the service shops make repairs, they have as their most important duty the *prevention of failures*. Tests of radio units at regular intervals show the lowering resistance of by-pass condensers, the weakening of tubes, the deterioration of resistors, etc. All tuning controls are realigned. In addition to the duties already described, this shop installs "conversions" in removable radio units. These conversions, either brought out by the manufacturers of the radio equipment or by the airline radio engineering department, are made to correct an inherent apparatus defect which makes its appearance when the equipment is placed in service or to modernize a unit when it has approached obsolescence.

Sometimes a second type of radio-repair shop is employed. This shop installs and repairs the "permanent" portion of the radio equipment. This equipment consists of the radio racks, antennas, volume-control panels, conduit, and wiring. This shop is employed because the servicing of permanent equipment involves dismantling certain portions of the airplane and this can be done only during the time of airplane overhaul. If this second shop is not employed, its functions are performed by a shop located at the main airplane repair base, and removable equipment is serviced at the same point. Since the installation of new radio units requires wiring changes in the airplane, all these are made by the permanent-equipment repair base. This base must employ men who not only have radio ability but who

have also a good knowledge of airplane mechanical work and can bend conduit and construct mounting brackets. Sometimes this permanent-equipment shop also is responsible for *all* airplane wiring.

Considerations in Ground-station Installations.—Besides the installation in the airplane, aeronautical radio requires extensive ground station installation; for few of the units on an airplane can produce the desired results without their counterpart in ground-station equipment. A large part of these ground-station installations are owned and maintained by the Federal government. In this country, the airline operators own and maintain only stations responsible for direct communication with the airline's own airplanes. In Europe, even this facility is the function of the government.

Characteristics of Ground-station Installations.—The aeronautical ground-station radio equipment is not, of course, limited by weight but it does have some characteristics not in common with other communication equipment.

One of these is the necessity for mobility. Route change, facility changes, or changes from one type of equipment to another make it necessary that rapid installations may be made. It also follows that the equipment should be designed into a number of smaller units that can easily pass through the average door. Since there is no direct relation between the air-line income and transmitter power and since the tube complement cost is multiplied by the number of stations owned by the airline, power should be kept at a minimum. This also applies to the transmitter circuits used. A minimum number of circuits should be employed, and the design should not include additional doublers or isolation amplifiers unless they provide undeniable advantages. A broadcast (amusement) station can afford these but not the aeronautical station.

Ground stations are, in general, serviced not by the local operator but by traveling radio servicemen. This is true of both government- and airline-owned stations. The reason for the adoption of this practice was to ensure uniformity of service. Also, the men charged with the operating duties do not have time to maintain the radio-station equipment. The labor of traveling servicemen is costly since the living expenses of these men must be paid in addition to their salaries; therefore, all ground-station

equipment should be designed so that all parts can readily be examined. As with the aircraft servicemen, the purpose of the ground-station servicemen is not primarily to repair equipment after it has failed but to locate evidence of equipment deterioration before failure occurs. It is unreasonable, then, to construct the equipment so that terminals and component radio parts are hidden beneath chassis and then pay a salary to a man who must discover them. Also, it must be remembered that the unit which will receive the best inspection is that which is the easiest to inspect.

Appearance of ground-station equipment should not be a primary consideration in its design. A neat front panel is all that is required. The interior should be designed entirely with respect to service.

Since the aeronautical ground-station operator is interested not in the radio part of the equipment but only in the results he obtains with it, controls should be kept to an absolute minimum. All controls not necessary to operate a unit (such as tuning controls of a transmitter) should be located behind a panel and the opening of the panel so arranged that tampering will be discouraged.

Problems

1. If the radio equipment in an airplane with a provisional gross weight of 23,000 lb. is 250 lb., and it is desired to install a 500-lb. radio installation in an airplane with a provisional gross weight of 55,000 lb., what arguments can you advance to justify the increased equipment weight?

2. Develop the equation that may be used to calculate the curve shown in Fig. 5.

Bibliography

1. WALLS, H. J.: The Civil Airways and Their Radio Facilities, *Proc. I.R.E.*, December, 1929, p. 2152.
2. SEYMOUR, LESTER D.: Radio for the Air Transport Operator, *Proc. I.R.E.*, December, 1929, p. 2140.
3. LEWELLYN, F. B.: Constant Frequency Oscillators, *Proc. I.R.E.*, December, 1931, p. 2063.

CHAPTER II

THE RADIO RANGE

As mentioned in Chap. I, the primary guidance for aircraft in the United States is the radio beacon, or radio range. Guidance supplied by this device simulates a radio road between all the principal cities in this country. Although this system enjoys the widest use in the United States and has been developed here more extensively than elsewhere, the original patent covering

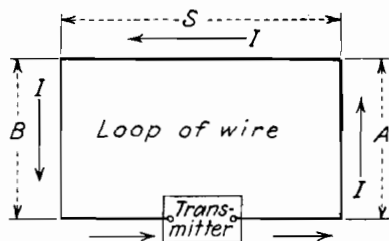

FIG. 9.—Current flowing in a simple loop antenna.

this device was issued by Germany in 1907 to O. Scheller. A similar British patent was granted the Marconi Company and Henry Round in 1909. In 1912, Marconi and Charles Price were granted a patent substituting loop antennas for the original directional antennas. In about 1923, the Signal Corps of the United States

Army and the National Bureau of Standards developed a radio-range system employing a Bellini-Tosi goniometer in order to permit rotating the range courses at will. This range system, in simple and modified forms, is still used in this country.

The first U. S. radio ranges were designed based on the peculiar directional characteristics of transmitting loop antennas, so loop field patterns will first be discussed.

Field Pattern of a Loop.—Suppose that a long piece of wire shaped so that it forms a rectangle, with the ends of the wire terminating in the center of one of the sides, is installed in the center of a circular race track with the plane of the wire vertical; further, suppose that the terminals of the wire are connected to a radio transmitter (see Fig. 9) and a suitable voltmeter (one which will read radio-frequency voltage) is used to take field-strength readings around the circular track. It will be found that a point exists where the voltage reads some maximum value

(for example, 10 volts) when the voltmeter is in a position exactly in line with the plane of the loop. A point will also be found where the voltage read by the meter is zero. This point is in line with the normal to the plane of the loop. If vectors (lines) are drawn with lengths corresponding in units to the observed voltage (for example, a 10-unit length corresponding to 10 volts) and the position of each vector corresponds to the position in which the voltages were read, a field pattern results. For clarity, it is common practice to erase the vectors and draw lines connecting their outermost terminals. The resulting lines represent the loci of all vector terminals associated with the particular electric field in question. When this is done for the field from the rectangular wire described, two tangential circles result. These are shown in Fig. 10.

It is clear that the distance from the center of this pattern (point of tangency of the two circles) to any point on the circle peripheries represents the magnitude of the voltage at any arbitrary distance from the antenna but for a position at some given angle (θ in Fig. 10) to the antenna array.

The preceding discussion relating specifically to a loop antenna also serves to describe a field-strength pattern for any antenna array. A field-strength pattern is a line joining the extremities of vectors, the origin of which is the center of any antenna array. Each vector represents the voltage at a given angle from an arbitrary line drawn through the antenna array. The field-strength pattern for the loop is the pattern for the horizontal plane only. Similar patterns can, of course, be drawn to represent the field strength in the vertical plane.

Returning to the field-strength pattern of the loop antenna, if the angle between any vector and the plane of the loop is designated as θ , the value of the vector will be

$$E = E_{\max} \cos \theta \quad (1)$$

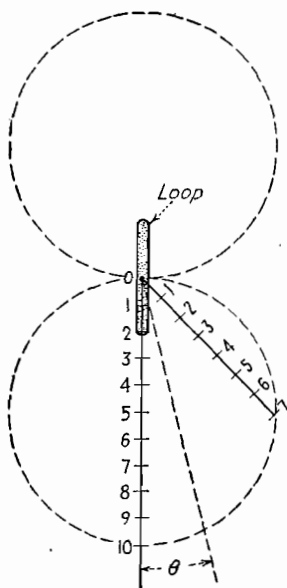

FIG. 10.—Field pattern resulting from plotting vectors corresponding to measured voltages.

In this equation E_{\max} is the voltage read at a position in line with the plane of the loop.

Proof of Equation.—Referring to Fig. 9, a transmitter will be seen feeding current to a loop antenna. The loop antenna has a rectangular configuration, but any configuration can be resolved into a structure having a vertical and horizontal member; so the theory about to be developed, with some slight modification, will hold for any loop.

Suppose that the periphery of the loop antenna is short compared with the wave length of the voltage connected to it, then the current will be essentially the same everywhere along the loop. This current I flowing through an increment of length Δh will cause a voltage Δe in space. This may be expressed by

$$\Delta e = \Delta h I \quad (2)$$

The current in one side of the loop, however, is flowing in a direction opposite to the current in the other side of the loop, so the voltages produced in space are equal and opposite. As the propagated waves generated by the individual sides of the loop travel through space, they meet at various points. If the distances traversed by the various waves are equal, there will be no phase change and cancellation will result, the resultant field being thus made zero. If, however, there is a greater distance traversed by one wave than by the other, the phase of the wave traveling the greatest distance will be retarded, and the sum of the two voltages will have some finite value. If one wave could be made to travel a distance one-half wave length greater than the other, there would be a phase retardation of 180 deg., or the waves would be in phase, and the voltage at the point where this occurs would be twice that generated by one side.

Figure 11 shows the plan view of the loop. It is apparent that the voltage generated by current flowing through an increment of loop in the top and bottom wires will contribute nothing to the vertical field. Since the point P is farther from one vertical member of the loop than the other, there will be a phase difference between the voltages from these vertical sides and, consequently, their vector sum will be some finite value.

This vector addition is shown in Fig. 12. The voltage E_A is equal to voltage E_B and opposite in phase as originally generated. As these voltages travel distances d_1 and d_2 , which are assumed to be great compared with the element spacing s ,

their relative intensities remain the same, but because d_2 is greater than d_1 (for point P of Fig. 11) the vector E_B will be

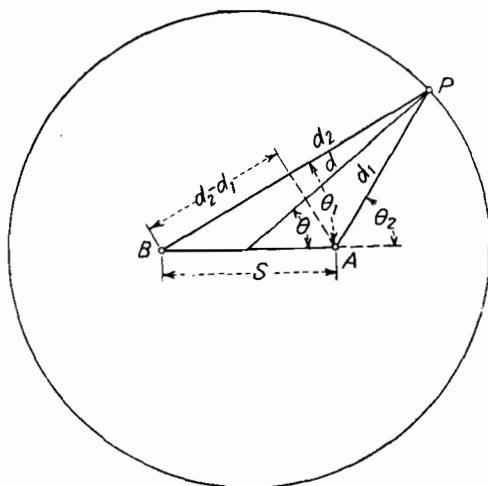

FIG. 11.—Currents flowing in loop sides A and B set up a field at point P .

retarded in time by an amount greater than the retardation of the phase of the voltage from E_B . This amount is shown as ϕ .

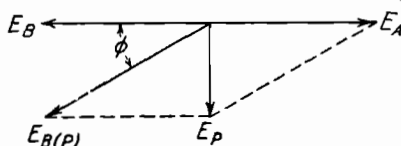

FIG. 12.—Vectorial addition of the voltages at point P .

The phase angle ϕ is a function of the difference between d_2 and d_1 . From trigonometry the resulting voltage will be

$$\frac{E_P}{\sin \phi} = \frac{E_A}{\sin \left(\frac{180 - \phi}{2} \right)} \quad (3)$$

In this expression, the voltage E_A is the voltage induced at the point P by the current flowing through element A of the loop. Then

$$E_P = E_A \frac{\sin \phi}{\cos \phi/2} \quad (4)$$

$$E_P = 2E_A \sin \frac{\phi}{2} \quad (5)$$

If in Fig. 11, d , the distance from the center of the antenna, is very great as compared with the spacing s , it can be assumed without appreciable error that

$$\theta_1 = \theta_2 = \theta \quad (6)$$

Then it is evident (see Fig. 11) that the difference between the paths traversed by voltages from A and B will be

$$d_2 - d_1 = s \cos \theta \quad (7)$$

Assuming that the waves propagate with the velocity of light

$$\phi = \frac{d_2 - d_1}{\lambda} \cdot 2\pi \quad (8)$$

$$\phi = \frac{2\pi s}{\lambda} \cos \theta \quad (9)$$

or

$$E_P = 2E_A \sin \left(\frac{\pi s}{\lambda} \cos \theta \right) \quad (10)$$

If

$$\frac{\pi s}{\lambda} \cos \theta = \delta$$

the preceding expression reduces to

$$E_P = 2E_A \sin \delta \quad (11)$$

By examining δ it can be seen that it will vary from 0 to $\pi s/\lambda$ as θ varies from 90 deg. to zero. If the spacing s between the loops is small in comparison to λ , δ will always be small or

$$\sin \delta = \delta \quad (12)$$

From which it can be written that

$$E_P = 2E_A \delta \quad (13)$$

$$E_P = 2\pi s \frac{E_A}{\lambda} \cos \theta \quad (14)$$

It is apparent that the greatest value of E_P occurs when $\theta = 0$, $\cos \theta = 1$, or

$$E_P = E_{\max} = 2\pi s \frac{E_A}{\lambda} \quad (15)$$

or substituting in Eq. (14)

$$E_P = E_{\max} \cos \theta \quad (1)$$

The Radio Range.—The radio-range system makes use of two loop antennas spaced at right angles to each other. The field patterns of the two antennas are identical except that they are displaced in space by 90 deg. In terms of an angle referred to the plane of the *first* loop, the field strength will be given by the expression

$$E_{\text{loop}(2)} = E_{\text{max}} \sin \theta \quad (16)$$

At an angle to the plane of the first loop equal to 45 deg. and *only* at this angle, the sine and cosine of θ will be equal (and have a value of 0.707). The foregoing discussion refers to the field

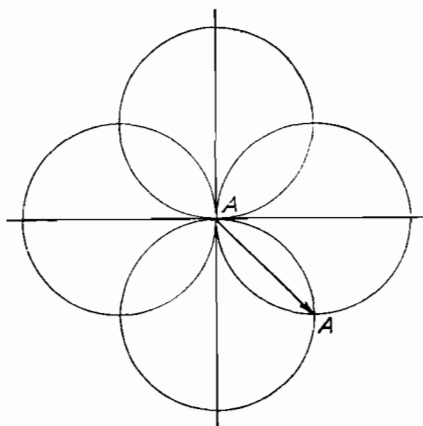

FIG. 13.—Field pattern produced by two loop antennas placed with their planes at right angles to each other. The antennas are not excited simultaneously.

strength from the second loop assuming that a transmitter is not connected to the first loop. If a field-strength meter is placed at an angle of 45 deg. to the plane of either loop and a transmitter is connected first to one loop and then to the other, there will be no difference in the reading of this meter. This is evident from an examination of Fig. 13. The radio range makes use of this principle. A transmitter modulated with a tone to which the ear is sensitive is alternately connected first to one loop and then to the other. It is connected to one loop for 3 sec., to the second loop for 1 sec., back to the first loop for 1 sec., and back again to the second loop for 3 sec. If a listener equipped with suitable radio-receiving apparatus is located at a position that makes an angle of 45 deg. to the plane of one

loop, the switching of the transmitter from loop to loop will not be observed, and a continuous long tone will be heard for 8 sec. If, however, the listener is located at a position directly in line with the plane of one loop (such as the number one loop), a tone will be heard for 3 sec. followed by a 1-sec. break and a 1-sec. tone. If the listener is located in line with the plane of the second loop, the converse is true. A 1-sec. tone will be heard, followed by a break and a 3-sec. tone. This phenomenon is shown graphically in Fig. 14.

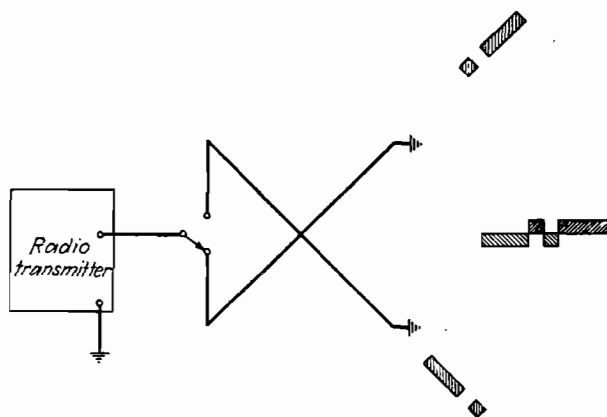

FIG. 14.—Diagrammatical representation of the principles of the aural radio range.

Range Characteristics.—Between the two extreme positions in line with the plane of the loops, varying amounts of the second signal will be heard. The positions in line with the 45-deg. angles to the planes of the loops are considered the courses of the radio range. Theoretically, it can be seen that there is one, and only one, angle (for one quadrant) where the two signals (Morse code *A* and *N*) have equal intensities, but since this comparison of signal strength is made not with an accurate voltmeter but by ear, there is some inaccuracy in the measurement, which causes the course to have an apparent width. This width will be narrower close to the station where the signal strength is great and cannot be influenced by noise and will be wider at the extremities of the useful range of the radio beacon. This width is generally considered to be a total of 3 deg. On either side of the course there is an area referred to as the twilight zone.

This is a zone where a weak opposite signal will always be heard, that is, where one signal always has an appreciable intensity as compared with the stronger signal. Obviously, this area is a function of receiver-sensitivity adjustment. In general these areas are regarded as having a width of 3 deg. Beyond these areas lie the *A* and *N* quadrants.

The United States Range System.—The radio range in the United States operates on frequencies in the range from 200 to 400 kc. These stations are spaced at distances of about 200 miles. After several successive transmissions of the *A* and *N* signals lasting about 30 sec., there is an interruption followed by a code signal sent first from the *N* loop then from the *A* loop. This code signal serves to identify the various stations. As the pilot reaches the point where the intensity of the range he is following has weakened, he tunes in the beacon ahead by referring to a chart and map on which the various stations are designated. There is a total of about 200 range stations located in the United States. The frequency separation between stations is often only 3 kc., and many stations with sufficient geographical separation operate on the same frequency.

Characteristics of Range Loops.—The effectiveness of a radio range (employing loop antennas) is largely a function of the loop design. The United States ranges employ polygonal loops 50 ft. high, 200 ft. across the base, and 30 ft. on the extreme sides. Small radio-range systems called "localizers," intended to furnish aircraft guidance only from the time that an airplane leaves a main range course to the time that it reaches the airport (a distance of not more than 20 miles), employ smaller triangular loop antennas with 60-ft. bases and 30-ft. heights. Loop antennas have three characteristics of importance to the designing engineer. The first of these is the effective height. The current in the loops multiplied by this effective height determines the signal strength output. The effective heights of loop antennas have been worked out by many engineers, but the most thorough treatment of the single-turn loop (the loop most commonly used for radio-range transmitters) is that by V. I. Bashenoff and N. A. Mjasoedoff. Their expression follows(1): where

$$h_e = \frac{Kh}{k} \quad (17)$$

where $K = \frac{2\pi S}{Ph}$

$$k = \frac{\lambda}{P}$$

h_e = effective height, meters

h = maximum dimension of loop perpendicular to the ground, meters

P = perimeter of loop, meters

λ = wave length, meters

S = area inclosed by loop, square meters

This formula is a modification of the standard formula for a loop the size of which is small in comparison to the wave length of the energy that the loop is transmitting. The better known formula follows:

$$h_e = \frac{2\pi S}{\lambda} \quad (18)$$

It can easily be proved that this expression is identical with that of Eq. (17). In Eq. (17), K has definite values for various loop configurations. Its value is $\pi/2$ for an isosceles triangle, circle, and square. In a transmitting loop, however, the perimeter is often as long as $\lambda/4$, and for this case Bashenoff and Mjasoedoff develop the following expression:

$$h_e = h[\phi(k) - \phi(k_1)] \quad (19)$$

In this expression, applying principally to an isosceles triangle,

$$\phi(k) = \frac{2k}{\pi} \sin^2 \frac{\pi}{2k}$$

$$\phi(k_1) = \frac{2k_1}{\pi} \sin^2 \frac{\pi}{2k_1}$$

$$k_1 = k \left(\frac{P}{2h} \right)^2$$

This formula will often give results differing from those obtained by the use of Eq. (17) by as much as 30 per cent.

The inductance of single-turn loops is of interest from a design standpoint. This inductance is given by(2)

$$L = 2P \left(\log_e \frac{2P}{r} - a + \delta \right) \times 10^{-3} \quad (20)$$

In this expression, P = perimeter of the loop, centimeters
 r = radius of the conductor, centimeters
 L = inductance, microhenrys

In order to determine a and δ , it is first necessary to calculate x from

$$x = 0.2142r \sqrt{f}$$

and y from

$$y = \frac{P}{\sqrt{S}}$$

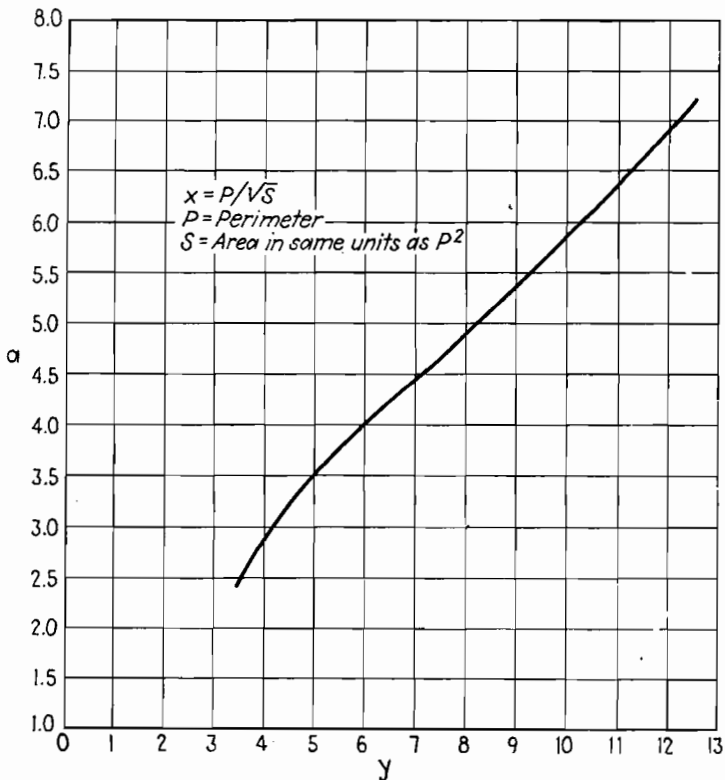

FIG. 15.—The value of a for use in formula (20). (Courtesy of Institute of Radio Engineers.)

Then the values for these quantities can be read from the curves of Figs. 15 and 16. These values hold only for nonmagnetic

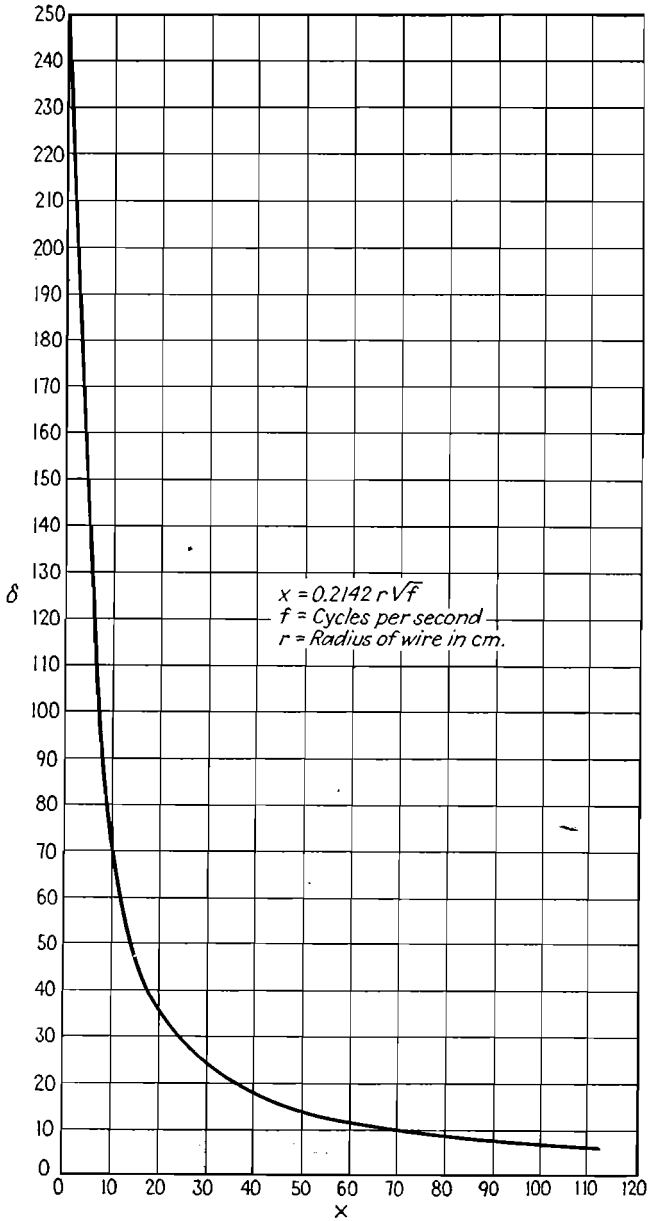

FIG. 16.—The value of δ for use in formula (20). (Courtesy of Institute of Radio Engineers.)

loop conductors. The following values for a apply to the following structures:

Circle.....	2.451
Square.....	2.853
Equilateral triangle.....	3.197
Regular hexagon.....	2.636
Regular octagon.....	2.561
Equal-leg right triangle.....	3.332

In order to determine the signal strength that will be produced by a loop antenna, it is necessary to know the current flowing into a loop, as well as its effective height. This current is a function of transmitter power and antenna resistance. Unfortunately, this latter quantity does not lend itself readily to computation. Certain currents in the loop flow to ground before traveling the entire perimeter of the loop, so the virtual resistance calculation is further complicated. In making certain preliminary designs, however, an approximate answer is often of help, and consideration of certain factors that make up the resistance of a large loop antenna makes possible an approximate calculation. Some of the resistances that enter to make up the total resistance of a loop are the resistance of the wire, the resistance equivalent of the dielectric losses, the resistance due to eddy-current losses in the ground, and the radiation resistance.

If the losses due to eddy currents are neglected, the following expression for the loop resistance(3) may be written:

$$R_1 = R_w + R_r + R_d \quad (21)$$

$$R_w = 0.0001 \frac{P \sqrt{f\rho}}{\pi d} \left(1 + \frac{\sin 2\pi/k}{2\pi/k} \right)$$

where f = frequency, cycles per second

d = wire diameter, centimeters

ρ = specific resistance, microhms per cubic centimeter

k and P have been previously defined

P is in centimeters

$$R_r = 1,600 \frac{h_e^2}{\lambda^2}$$

$$R_d = 17k \left(1 - \cos \frac{\pi}{k} \right)^2$$

After other loop constants have been calculated, the engineer will wish to estimate the strength (maximum) of the signal that

will be emitted by the loop. If the transmitter to which the loop is connected has an output power of P_0 watts, the current flowing into the terminals of the loop can be calculated from

$$I = \sqrt{\frac{P_0}{R_1}} \quad (22)$$

The field strength in millivolts per meter at 1 mile from the loop will then be(4)

$$E_f = 234I \frac{h_e}{\lambda} \quad (23)$$

In this expression I is in amperes and h_e and λ are in meters.

Field strength at distances greater than 1 mile involves consideration of the propagating medium and its attenuation. This subject will be discussed later. Before closing the subject of loop characteristics, it is necessary to mention that the loops must be balanced electrically with respect to ground. If this is not done, the capacity current flowing between each side of the loop and ground will not be equal, and, hence, the greater current flowing through one side of the loop will produce greater voltage than the other side. This will then cause an irregular pattern in space instead of the regular figure 8 pattern.

Course Rotation.—In 1907, E. Bellini and A. Tosi developed a system of direction finding that eliminated the necessity for rotating the direction-finding antenna. This system made use of a radio-frequency transformer of unique design known as a goniometer. The men of the Signal Corps and Bureau of Standards working on this problem modified this goniometer to produce a means for rotating the range course at will without the necessity of moving the range antennas.

The goniometer now used consists of a radio-frequency transformer with two primary and two secondary windings. The secondary windings are mounted on a structure outside of the primary structure. The inner structure is mounted on a shaft so that it may be rotated and the coupling between the secondary windings and the primary windings can be varied from a certain maximum value to nearly zero. The two primary windings are at right angles to each other, and this also is true for the two secondary windings (see Fig. 17). The secondary windings are connected one to each of the loop antennas. A motor-driven switch alternately connects the transmitter first to one then

to the other primary winding for periods required to generate the Morse code *A* and *N* as was previously described (see Fig. 18). One primary winding will deliver all its energy to only one second-

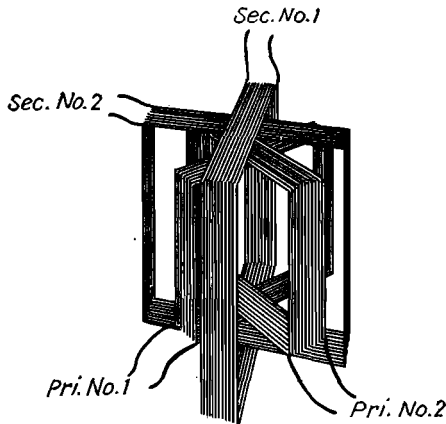

FIG. 17.—The aural-radio-range goniometer.

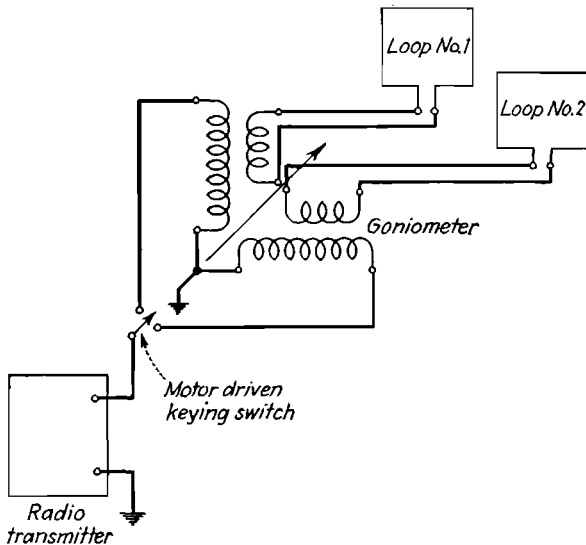

FIG. 18.—Connection of a goniometer in an aural radio range.

ary winding if that secondary is coaxial to it alone. This is because under these conditions the coupling between this particular primary winding and the other secondary winding is

zero, while it is a maximum with respect to the coaxial secondary. If it is assumed that the coaxial secondary is connected to the No. 1 loop antenna and the primary with which it is coaxial is that which is keyed with N signal energy, then the No. 1 loop will send out only N signals and in the interval between the energy periods, it will not be energized. This is because the secondary to which it is connected is at zero coupling to the other primary. As the secondary windings are rotated so that the secondary connected to the No. 2 loop is coaxial with the N primary, the No. 2 loop will send out the N signals. Thus, the course of the range has been rotated by 90 deg. (in space).

Suppose now that the secondaries of the goniometer are rotated so that neither are coaxial with the primary coils but each has a 45-deg. relation to the primaries. Then the N primary will deliver equal energy to both the No. 1 and No. 2 loops; also the A primary will deliver equal energies to these loops. In space, the radiation from the two loops combines (since energy is being emitted from both loops simultaneously), and the direction of maximum field strength will no longer be in the plane of either of the loops but will be in a plane at 45 deg. to the plane of the loops. The same equation for field strength ($E = E_{\max} \cos \theta$) will hold, but in this case θ must be taken as the angle to the maximum radiation plane. If an observer did not know that a goniometer was in use and made the tests described under Field Pattern of a Loop, he would assume that the loops were located at 45 deg. to their actual position. For purposes of calculation, the planes containing the direction of maximum energy are called the phantom loops because it appears that the real loops have been rotated to this fictitious position. The goniometers are so designed that the coupling between primary and secondary windings is a sine or cosine function of the angle of rotation. If M_{\max} is the maximum coupling between primary and secondary, then for one primary winding the mutual inductance is (5)

$$M_N = M_{\max} \cos \theta \text{ for the No. 1 secondary} \quad (24)$$

$$M_a = M_{\max} \sin \theta, \text{ for the No. 2 secondary} \quad (25)$$

In these equations, θ is the angle between the primary under consideration and the No. 1 secondary. For the other primary winding

$$M'_n = M_{\max} \sin \theta, \text{ for the No. 1 secondary} \quad (26)$$

$$M'_A = M_{\max} \cos \theta, \text{ for the No. 2 secondary} \quad (27)$$

The current is a direct function of these mutual inductances when the secondaries of the transformers are tuned to resonance; therefore, if a current of 10 amp. is induced in the secondary when the coupling between primary and secondary is maximum (zero-degree position) this current will have a value of 8.66 amp. if the goniometer is rotated to the 30-deg. position, 7.07 amp. at the 45-deg. position, and 5.00 amp. at the 60-deg. position. The current in the other secondary will vary as the sine of the angle of rotation. That is, if the current in it is zero for the zero-degree position, it will be 5.00 amp. for the 30-deg. position, 7.07 amp. for the 45-deg. position, and 8.66 amp. for the 60-deg. position.

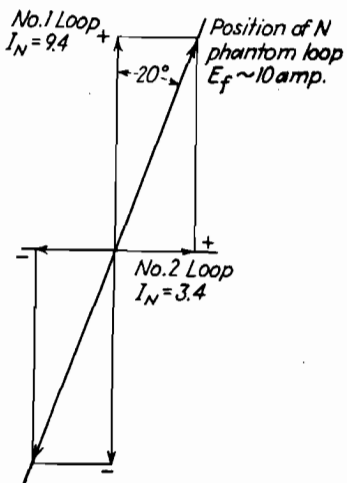

FIG. 19.—Position of the *N* signal phantom loop resulting from currents in both sets of loop antennas.

In space, the voltages produced by the currents in the two loops add vectorially. An example is shown on Figs. 19, 20, and 21. In Fig. 19 the goniometer has been rotated by 20 deg. The cur-

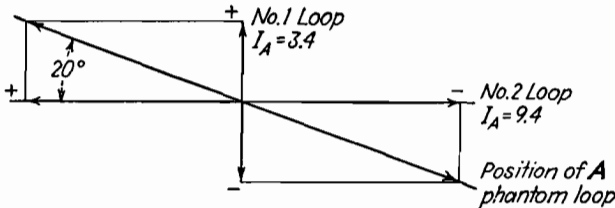

FIG. 20.—Position of the *A* signal phantom loop resulting from currents in both sets of loop antennas.

rent in the No. 1 loop (which normally sends out *N* signals) is reduced from its normal 10 amp. to 9.4 amp. ($\cos 20^\circ \times 10$) and the No. 2 loop now has in it 3.4 amp. ($\sin 20^\circ \times 10$). The resulting vector has exactly the same voltage as when the goniometer was in the zero position but has been rotated in a clock-

wise position by 20 deg. The direction of rotation is a matter of polarity of the windings. If the windings had a different polarity, the resulting vector might have rotated in a counterclockwise position. In Fig. 20, a calculation similar to that made for the N loop is made for the A loops. In Fig. 21, then, the resulting energy lobes and courses are shown.

It is very desirable that the rotation of the goniometer does not disturb the tuning of any portion of the antenna circuits. It is also necessary that the variation in mutual inductance with

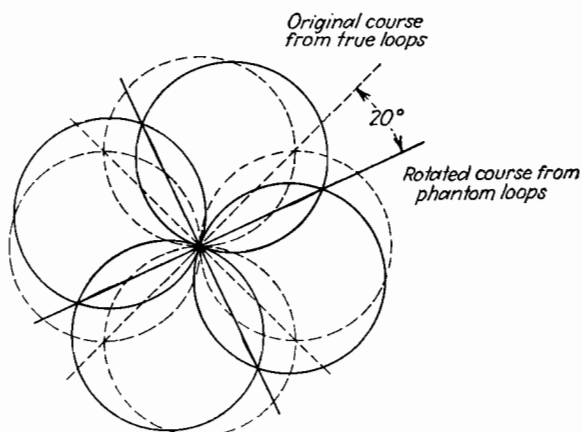

Fig. 21.—Field pattern of radio range generated by the phantom loops of Figs. 19 and 20.

goniometer rotation does not deviate from true sine and cosine functions. In order to meet both of the foregoing conditions, the coupling between primary and secondary must be maintained at a low value. The usual coefficient of coupling used in goniometers is not more than 20 per cent. The problem solved graphically in Figs. 19, 20, and 21 can, of course, be solved just as easily by algebraic methods. This method will be discussed in detail later. As far as the problem illustrated in Figs. 19, 20, and 21 is concerned, it is only necessary to know the angle of goniometer rotation, and the course shift will be known immediately.

Course Shifting and Bending.—By “course shifting” is meant the moving of the courses of a radio range from their normal 90-deg. displacement to any angle between courses of 60 to 120 deg. The term “course bending” is used to designate that the opposite courses are changed from their normal 180-deg. displace-

ment to a position where the angles between these courses have values of 150 to 210 deg.

The necessity for course bending and shifting lies in the necessity for arranging the legs of a range to bear on the various airways leading from a city. For example, the airways leading out of Albany, N.Y., lead to Poughkeepsie, N.Y., on the south; Springfield, Mass., on the east; Burlington, Vt., on the north;

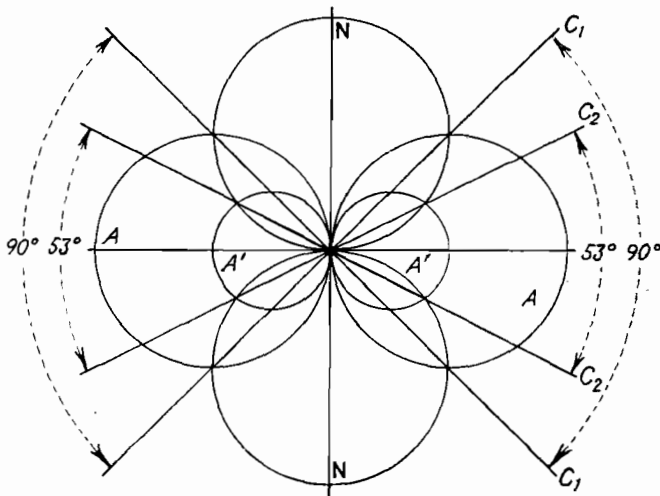

FIG. 22.—Course shifting resulting from a reduction in the A loop energy.

and Utica, N.Y., on the west. Seldom do the important cities adjoining a major city lie from it at all the cardinal points of the compass. In the case of the Albany station, the angle between the west and north leg is 85 deg., between the north and east 110 deg., the east and south 57 deg., and the south and west 108 deg. Neither a 90- nor a 180-deg. angle exists between any of the legs of this range. Since the bearings of these cities from Albany are not integral multiples of 90 deg., it is necessary to bend and shift the legs to bear on the appropriate routes.

As has previously been explained, range courses are in reality areas where the strength of the signals from the two loops is equal. If the field radiated by one loop of a pair is decreased by reducing its effective height, or by introducing resistance, the course will be shifted toward the weaker loop. This is illustrated in Fig. 22. In this figure the angle between the C_1 courses is the

normal 90 deg. when the energy radiated by both loops is equal; however, when the energy from the *A* loop is reduced to one-half that of the *N* loop, the courses move together to a new position *C*₂ with an angle between them of only 53 deg. (approximately). The angle between the courses can be calculated graphically as has been done in Fig. 22, or it can be calculated by simple trigonometry from

$$\theta = 2 \text{ arc tan } \frac{I_a}{I_b} \quad (28)$$

where θ = smallest angle

I_a = smaller of the currents in the two loops

I_b = larger currents in the two loops

In this expression the two loops are assumed to be identical; that is, for a given current in either loop, the same field strength is produced at an angle of 45 deg. to the plane of the loops. If a given course shift is desired, it is possible to compute from Eq. (28) the ratio of the two currents that is necessary in order to produce this shift. If the resistance of the loops and the available transmitter power are known, it is possible to compute the resistance that is required for insertion in one of the loops in order to obtain the desired shift. If each leg of a loop could be excited individually without reference to any other leg, it would be possible to produce bending very easily. The mere insertion of resistance would accomplish this effect, and the calculation would follow from what has been discussed for bending. For the tower range to be later described, bending is actually accomplished in this manner, but it is not applicable to the loop range.

In order to affect one leg of a radio range without affecting the other legs, it is necessary to add to the range a vertical antenna and the proper phase-shifting apparatus. This vertical antenna is so connected that it is energized at all times. In Fig. 23 is shown a standard range emitting field patterns *N*₁, *A*₁, *N*₂, and *A*₂. The resulting courses occupy positions designated by *C*₁. To this range is added a vertical antenna that emits the uniform field *V*. This energy adds and subtracts from the various loop field patterns, depending on the relative phase between the energy from the loops and the energy from the vertical antenna. Since the two lobes of energy emitted from a loop have opposite phases, the energy from the vertical antenna

adds to one lobe and subtracts from the other. The results are the lobes N_4 , A_3 , N_3 , and A_4 . The intersection of the resulting lobes produces the new courses. It will be seen that C_1 is now displaced and the angle between opposite courses is no longer 180 deg. The resulting angle is 203 deg. between the new courses C_3 . The new courses C_2 , however, although formed by the energy from fields of lower value than formerly, retain their

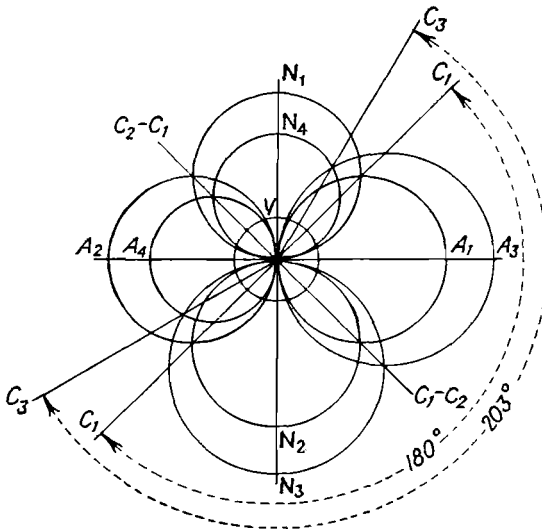

FIG. 23.—Course bending produced by the addition of a vertical antenna to the loop system.

same positions. If the field strength and phase of the energy from the vertical tower are known, the positions of the resulting courses can be calculated; however, the necessary data are difficult to obtain, and course bending is usually accomplished by experimental methods. It can be seen, however, that by using both course bending and shifting each leg of a range can be positioned so that it bears on any airway desired.

Night Effect.—The first United States ranges to go into the making of the present airway system were installed between Bellefonte, Pa., and New York City in the summer of 1927 and were test flown sometime in September of that year. In 1928, Haraden Pratt of the Bureau of Standards wrote a paper(6) describing night-effect phenomena.

This effect, noticed for the most part at sunset and after night-fall, is quite weird. If one is listening to the *A* signal from a station at some distance from the radio receiver, the signal will slowly fade and an interlaced "on-course" signal will be present in the output of the receiver. This signal will continue to change, and soon a predominant *N* signal will be heard. All this occurs without changing the position of the receiver.

After this, the reverse condition sets in and an *A* signal is again heard. This signal change will sometimes continue for hours. The phenomenon sounds as if someone at the transmitting station

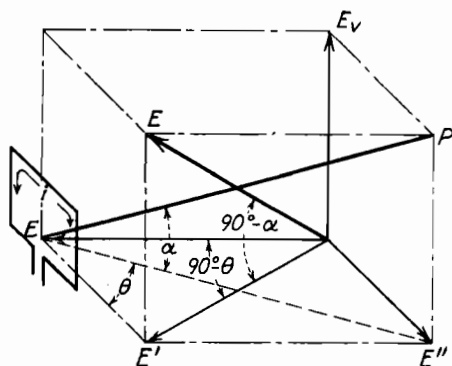

FIG. 24.—Electric field components produced by loop antenna.

were slowly moving the rotating coils of the goniometer to and fro.

This anomalous transmission is caused by the reflection of signals by the ionized gas layer located above the surface of the earth, often referred to as the Kennelly-Heaviside layer but more properly known as the ionosphere. The mechanism of transmission from this layer will be described later, but for the time being certain statements regarding the characteristics of this layer will be made, which the reader is asked to accept. Referring to Fig. 24, a loop antenna(7) will be seen in perspective. Current flowing through this loop is shown producing a magnetic vector at point *P*. At right angles to this magnetic vector is the corresponding electric vector *E*. From trigonometry the vector *E* can be resolved into three components—two in the horizontal plane and one in the vertical plane. The vertical vector voltage

E_v will be given by

$$E_v = E \cos \alpha \quad (29)$$

This component is the one that is normally polarized and is propagated via the ground and affects the receiver under normal conditions. The term $\cos \alpha$ serves to give E_v some constant value for the zenithal angle α . The vector E will be without value since it acts in a direction that does not affect the receiver, but the vector E_h will be propagated by the higher reflecting layers when the lower absorbing layers disappear at sunset. Normally this voltage is weaker than E_v , but when propagated under suitable ionosphere conditions it may have a field strength equal to the ground propagated wave E_v . This vector has for its value

$$E_h = E \sin \alpha \sin \theta \quad (30)$$

Notice that the angle θ in Fig. 24 is the same as angle θ in Fig. 10, and remember that the normal loop pattern was described as a function of the cosine of θ . For a given zenithal angle α , then, the voltage E_h acts as if it were radiated from a loop at right angles to the loop that is actually emitting this signal. For the position where the N signal should be zero, it will actually be some finite value, which value may be equal to the normal N value 90 deg. displaced from the point of reception of the false signal. By taking into consideration the fact that the amplitude of the spurious, as well as the true, signals may be changing as the propagating layer changes, it is evident that peculiar effects of any character may be observed.

The TL Range.—Since the E_h vector above is a sine function of the zenithal angle, this vector will be eliminated if the angle is zero. The original vector P occurred at some angle α merely because there were currents flowing through horizontal elements as well as through vertical elements. The elimination of all horizontal components should give α a permanent zero value. In the discussion of the derivation of the normal field pattern, it was said that the horizontal loop members did not contribute in any way to the field-strength pattern except that they served to furnish current to the vertical legs of the loop antenna. If it were possible to furnish this current and yet eliminate the horizontal legs of the loop, the same radio range would result except that night effect would no longer be present. The elimination of

the horizontal members was accomplished by using steel towers rather than loops and feeding these towers with buried transmission lines. These towers and the transmission lines connecting to them are shown in Fig. 25. This system became known in the United States as the *TL* range.

Characteristics of Range Towers.—Previously, methods for the calculation of the electrical characteristics of the loop antennas used with radio ranges were given, and it is desirable to discuss the electrical characteristics of the towers used with the *TL* range. Dimensions of a typical tower installation are shown in Fig. 25. It will be seen that each of the towers has a height of 125 ft.

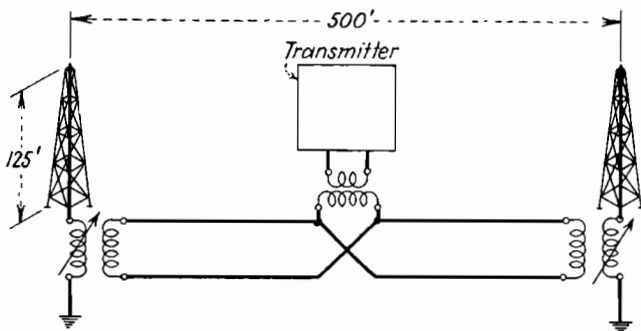

FIG. 25.—The *TL* radio-range antenna system.

This height is great, but it is smaller than that of many commercial broadcasting stations, the antennas of which often have a height of 500 ft. If the electrical height of these towers is computed for the frequencies between 200 and 400 kc., it will be found to be only between 9 and 18 deg.; thus these towers are really very short in comparison to the wave length. There are several reasons why taller towers with increased radiation efficiency cannot be used for this purpose. The most important reason is that they are all located near airports or at least on the airplane routes, and hence if they were high they would constitute a hazard. In addition, tall towers could not be constructed practically without using guy wires. These guys would fill the field between the towers and would probably serve to distort the courses. Although it is overshadowed by the other reasons, the cost of four large towers for each of nearly 200 stations would be a considerable sum.

The methods for calculating electrical characteristics of vertical antennas have been derived by several authors and would be given here except for the fact that these calculations were found to be inaccurate because of the extremely short electrical length of these towers. The largest portion of the resistance of these antennas is made up by ohmic resistance and dielectric losses. The radiation resistance computed for these towers was found to be only about 0.06 ohm, whereas the total measured resistance is actually about 1.5 ohms. The same condition is also true for the reactance of these antennas. All theoretical formulas are based on antennas with small cross sections. This is not true of the tower. The short tower acts as a lumped capacity of about 845 μmf . At 300 kc. the impedance of the antenna is $1.5 - j629$ ohms.

The current will be maximum at the base and zero at the top of a uniform vertical wire that is short compared with the wave length of the energy connected to it if the inductance and capacity per unit length are constant. Since the average current for such an antenna is one-half of the maximum current, the effective height will be one-half of the actual height(5). For the towers of Fig. 25, the effective height, by this formula, is calculated to be approximately 19 meters. The capacity of these towers is not uniform and is much greater at the base than at the top; accordingly, the effective height will be less than calculated above. This effective height has been measured as 16.1 meters. This calculation, therefore, is in error by 15.7 per cent. This error is high; however, the method of calculation is useful as a basis for an engineering approximation. The effective height of the system consisting of the two towers has been measured as 2.3 times the effective height of one tower.

The towers of these antennas are insulated from ground at each tower leg. The tower itself is secured to its foundation by a single insulated support in the center. The individual legs "float" on their insulators. Electrically, these insulators contribute to the high base capacity. The insulators used are comparatively short, and it was found that, in certain sections of the country, alkali dust would gather on them. When it rained, a conducting path to ground was formed, which caused the courses to shift. In order to prevent this occurrence, each tower leg is fitted with a "skirt" over each insulator. This skirt is in

the form of an inverted funnel which serves to prevent rain and other matter from falling on the surface of the insulator.

Design of Output Circuits for the TL Range.—In developing the tangent circle pattern (commonly called figure 8) for the loop antenna, it was assumed that the phase relation between the two currents in the vertical legs of the loop antenna was 180 deg. This relation holds true by the mechanical construction of the loop antenna. The current flowing from the source upward in one leg must flow downward in the opposite leg in its return to the source. Such a relation, however, need not be true for the vertical antennas. By referring to Fig. 12, it can be seen that if the relation between voltage E_A and E_B is no longer 180 deg., the resulting sum of these voltages will have some other value than that given by Eq. (1). Actually, the resulting field pattern can have any form. It may be a cardioid or a figure 8 displaced 90 deg. to the normal pattern. Under Course Shifting and Bending was explained the dependence of the course position on the relative currents in the two loops and also (when the vertical antenna was added) to the relative currents in each lobe of the loop pattern. It is evident, then, that in order to maintain course stability the phase relation as well as the ratio of the currents in the individual lobes must always remain constant, that is, if the courses are to remain in the position to which they are originally set.

As has previously been discussed, the Q (ratio of reactance to resistance) of the United States *TL* tower antenna is very high, and therefore slight changes in capacity of the antenna cause serious detuning and the current change through the antenna will be great. Since such changes in electrical characteristics can be caused by moisture and other atmospheric conditions, it becomes necessary to design an output coupling system that will reduce their effects on course stability. In Fig. 26 is shown the schematic circuit of the output system actually used. The transmitter is connected to the link circuit relay. This relay is motor operated and keys the *A* and *N* signals previously described. Next to this relay is the course shifting pad which reduces the current in one pair of towers. From the pad the energy flows through the condensers C_{1a} and C_{1n} which serve to resonate the primaries of the goniometers G_{1a} and G_{1n} . To these primaries are coupled the goniometer secondaries G_{2a} and G_{2n} .

resonated by the condensers C_{2a} and C_{2n} . From these secondaries the current flows to two sections of artificial line in the form of two π sections. From here the energy travels through under-

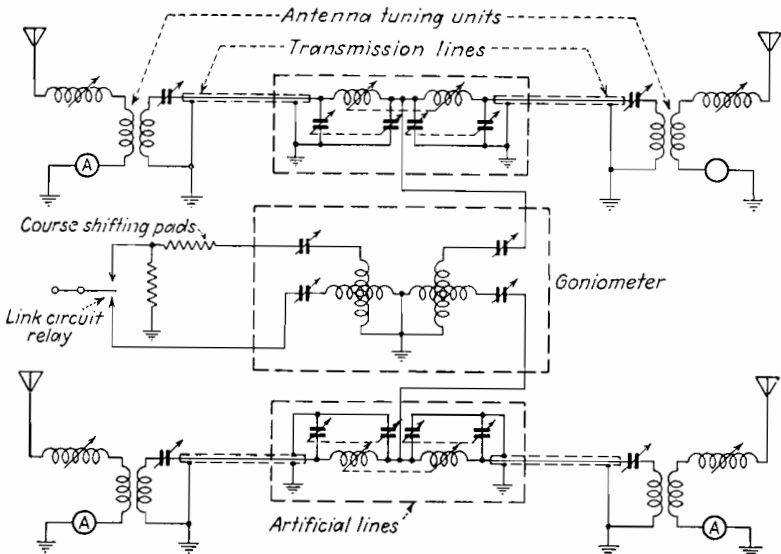

FIG. 26.—Schematic diagram of radio-range coupling system. (Courtesy of C.A.A.)

ground transmission lines to the secondary resonating condensers C_{Aa} and C'_{Aa} of antenna transformers. The secondaries of these transformers are resonated by varying the inductance. In Fig.

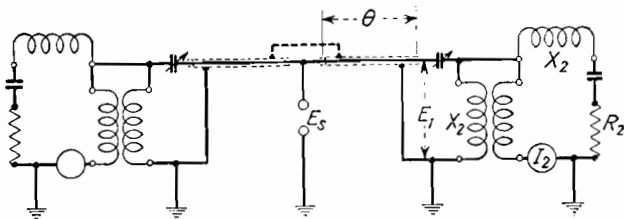

FIG. 27.—Schematic diagram of coupling system used to excite one pair of diagonally opposite radio-range antennas. (Courtesy of C.A.A.)

27 is shown the electrical equivalent of one of the tower circuits (6). If the voltage at the terminals of one antenna transformer is E_1 , it will cause a current I_1 to flow in the primary and a current I_2 in the secondary of that transformer. If the primary imped-

ance of the transformer is Z_1 , the secondary is Z_2 , and the total secondary is Z_{12} , the primary and secondary circuit equations can be written as follows:

$$E_1 = I_1 Z_1 + I_2 Z_{12} \quad (31)$$

$$0 = I_1 Z_{12} + I_2 Z_2 \quad (32)$$

Before proceeding, it may be well to explain the terms Z_{12} , Z_1 , and Z_2 . The term Z_{12} is a mutual term and describes the values of impedance reflected from primary to secondary, or vice versa; the terms Z_1 and Z_2 represent the characteristics of primary and secondary (respectively) alone, without considering the values reflected by the coupling. The term Z_2 covers all secondary values including the characteristics of the secondary tuning units and antenna.

Equations (31) and (32) can be simplified to

$$I_2 = - \frac{E_1 Z_{12}}{Z_1 Z_2 - Z_{12}^2} \quad (33)$$

$$I_1 = - \frac{I_2 Z_2}{Z_{12}} \quad (34)$$

The voltage impressed at the sending end of a transmission line can be expressed in terms of receiving-end conditions by

$$E_s = E_1 \cos \theta + j I_1 Z_0 \sin \theta \quad (35)$$

In this expression the angle θ is the electrical length of the line in degrees so that

$$\theta = \frac{2\pi S}{\lambda} \text{ in radians} \quad (36)$$

or

$$\theta = \frac{360S}{\lambda} \text{ in degrees} \quad (37)$$

The antenna current I_2 is a function of the sending-end voltage and the impedance interposed between this sending-end voltage and the antenna. This impedance is commonly called the "transfer" impedance. This transfer impedance can be expressed by dividing Eq. (35) by Eq. (33) and substituting for I_1 its value given in Eq. (34)

$$E_{s2} = \frac{E_s}{I_2} = Z_{12} \cos \theta - \frac{Z_2}{Z_{12}} (Z_1 \cos \theta + j Z_0 \sin \theta) \quad (38)$$

It can be seen that only the second term of Eq. (38) contains the antenna impedance; therefore, it follows that if this second term could be made zero, the antenna current would be

$$I_2 = \frac{E_s}{Z_{12} \cos \theta} \quad (39)$$

and hence would not be a function of the antenna impedance. To express it in other terms, the antenna could be detuned without its current changing if power supply regulation is perfect. To make the second term of Eq. (38) zero, the expression in the bracket should be zero, thus:

$$Z_1 \cos \theta + jZ_0 \sin \theta = 0 \quad (40)$$

$$Z_1 = jZ_0 \frac{\sin \theta}{\cos \theta} = jZ_0 \tan \theta \quad (41)$$

If primary resistance is neglected,

$$x_1 = -Z_0 \tan \theta \quad (41a)$$

and

$$Z_{s2} = jX_{12} \cos \theta \quad (41b)$$

It is possible to make a circuit that will satisfy Eq. (41) except when $\theta = 90$ deg., at which time $\tan \theta$ equals infinity.

In practice, θ is always much less than 90 deg., so no difficulty is experienced in satisfying the terms of Eq. (41). When this relation is satisfied, the ratio of E_s to I_2 remains constant as the antenna is detuned. By looking at Fig. 27 it can be seen that the voltage E_s is common to both antennas; hence, if antenna A is detuned, the ratio of E_s/I_2 remains constant and therefore the antenna current in the diagonally opposite antenna will change in the same proportion. Thus, if all four antenna circuits are adjusted to satisfy Eq. (41), the established phase and amplitude relations of the currents in the opposite pairs will be preserved even though the antennas may be detuned by random variations in capacity and resistance.

In addition to satisfying Eq. (41), it is also necessary that the impedance presented by each primary be equal to the line impedance in order that maximum power may be absorbed and standing waves on the transmission line may be eliminated. By using Eqs. (33) and (34), it can be shown that the total

impedance of the primary is

$$Z_{11} = \frac{Z_1 - Z^2_{12}}{Z_2} \quad (42)$$

which is the same as

$$Z_{11} = \frac{X^2_{12}R_2}{R^2_2 + X^2_2} + \frac{j(X_1 - X^2_{12}X_2)}{R^2_2 + X^2_2} \quad (43)$$

If the characteristic impedance of the transmission line is a pure resistance, which is true for the ceramic-air lines, the real part of the foregoing expression should be equal to the characteristic impedance of the line, and the reactive component should be zero.

$$Z_0 = \frac{X^2_{12}R_2}{R^2_2 + X^2_2} \quad (44)$$

$$0 = X_1 - \frac{X^2_{12}X_2}{R^2_2 + X^2_2} \quad (45)$$

If the phase angle of the antenna circuit is defined by

$$\psi = \arctan \frac{X_2}{R_2} \quad (46)$$

then Eqs. (44) and (45) may be written as follows:

$$X_{12} = \frac{\sqrt{Z_0 R_2}}{\cos \theta} \quad (47)$$

$$\tan \psi = -\tan \theta \quad (48)$$

Equations (47) and (48), then, must be true if the line impedance is matched.

If Eq. (41) is satisfied, (41b) will be a pure imaginary and will denote a 90-deg. phase difference between line voltage and antenna current. Under this condition, course alignment is restricted to that in which opposite courses are 180 deg. (space) apart. If it is desired to bend courses, it is not possible to satisfy Eq. (41). That is, if nonreciprocal course alignment is necessary, it is also necessary to depart from the most stable circuit adjustment.

Adjustment of the goniometer must also be discussed at this time. Suppose that the antenna circuits are adjusted to satisfy Eq. (41) but the courses are so aligned that the goniometer is in the zero position. This means that one pair of towers will be

energized only during the *N* interval and the other towers only during the *A* interval. If one of the towers (for example, an *N* tower) becomes detuned, the current in the other tower of the pair will also decrease by a corresponding amount, but the *A* tower currents will be unaffected. As has previously been shown, if the *N* energy lobes decrease but the *A* lobes retain their normal size, the courses will be shifted toward the *N* towers. Suppose, now, that the goniometer is set at its 45-deg. position; both of the goniometer secondaries will be equally coupled to the primary. Since the secondary windings are resonated, their entire voltage will appear across the transmission lines; hence the sending-end voltage will always be equal for any transmission-line impedance. If one of the antennas becomes detuned, the current will drop equally in all four towers, and although the received signal strength will be decreased, the course alignment will not change. In order to maintain the goniometer setting at 45 deg., it is necessary that the desired course alignment be known prior to the time that the towers are erected. Stability of courses is very important, and it is unfortunate that other demands make necessary the alignment of the radio range for conditions that deviate from maximum stability.

The Simultaneous Radio Range.—When the radio range was first placed into use in the United States, it was made to serve a dual purpose. In addition to providing guidance, its *A* and *N* signals were interrupted so that the weather in the area in which the range was located could be broadcast. This weather information is, of course, very valuable to a pilot, and while en route to a terminal, the momentary loss of the guiding signals is of small consequence. However, as the range began to be used as a means for allowing the pilot to come down through a solid overcast to a low ceiling, the loss of these guiding signals during the crucial descent period was a serious matter. Such an interruption meant that the pilot had to begin working out his instrument problem all over again. Not only was time lost, but invaluable quantities of gasoline were wasted. A procedure was, of course, set up whereby the range-station operators were notified during these times and the transmission of guidance signals was allowed to continue without interruption. This procedure disrupted the weather-broadcasting schedule and was unsatisfactory in other ways. A solution to this problem would

have been the placing of the weather broadcast on a separate frequency; however, this was not possible because the channels were already badly crowded. The solution that was developed is quite novel and consists(9) in transmitting the weather and range signals simultaneously with a means for selecting either type of signal at will. This solution consisted in adding to the

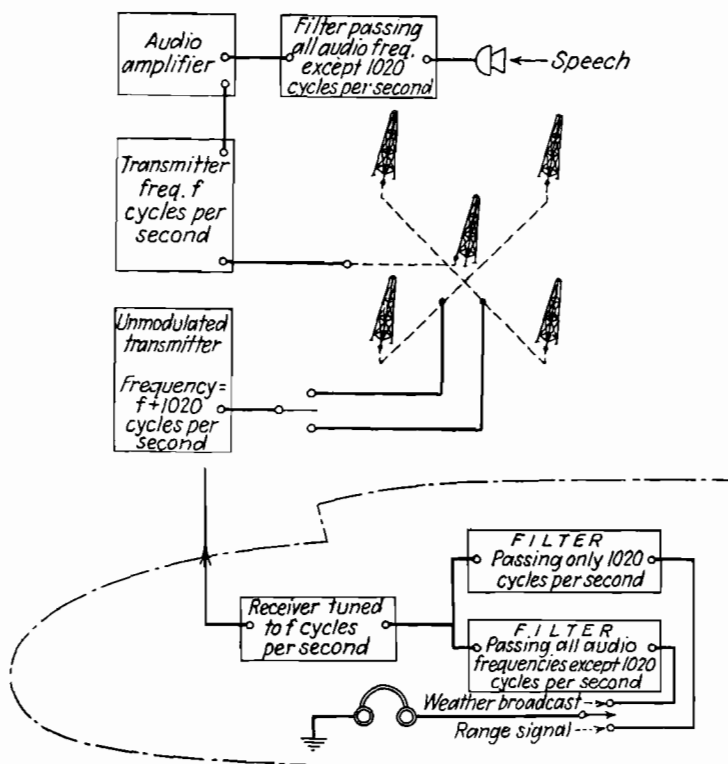

FIG. 28.—Principles of the simultaneous radio range.

TL range antenna system a fifth tower centrally disposed with respect to the four towers already in use. The range transmitter was shifted in frequency so that it now had a value that was 1,020 cycles higher than previously. To the central tower there was connected a new transmitter operating on the carrier frequency previously used by the range transmitter. The tone with which the range transmitters were modulated was removed so that they now transmitted only a pure carrier wave. In the radio receiver, the radio frequencies from the center tower and from the range towers beat together by virtue of the frequency

difference to produce a 1,020-cycle tone. This tone (frequency difference) was chosen because of the following reasons:

1. The ear is very sensitive to it
2. It is easily distinguishable above the noise of the airplane
3. It is pleasing to the ear
4. It is a multiple of 60 cycles, and consequently the commercial power source supplies a frequency standard

The transmitter connected to the corner towers of the range station is keyed from one pair of towers to the other in exactly the same manner as was previously done when it was used as a *TL* range; hence, an observer hearing the modulation that takes place in the detector of his receiver is unaware that this tone is not the result of modulation at the transmitter. The transmitter connected to the center tower must transmit continuously or else the tone in the receiver will disappear. When necessary, this center tower transmits weather broadcasts in the form of voice. A wave filter is, however, connected in series with the microphone circuit and prevents any 1,020-cycle tone in the speaker's voice from modulating the transmitter. Other voice frequencies must serve to carry the intelligibility to the pilot. In the airplane, two filters are connected to the receiver output. One of these passes only 1,020 cycles; this, then, passes the tone generated in the detector of the receiver. The other filter passes all frequencies except 1,020 cycles; hence, headphones connected to it will have only the weather broadcast impressed on them. By means of a switch, the pilot connects his headphones to the output of either filter at will and thus has the choice of weather- or range-guidance signals. This system is shown diagrammatically in Fig. 28. Since the generation of the tone signal actually occurs in the receiver, it is necessary that the relative amounts of power from the two transmitters be regulated so that the proper modulation takes place.

The statement was made that one of the filters passed only 1,020 cycles, whereas the other passed all frequencies except 1,020 cycles, but actually this is not the case. All filters must have an appreciable band width, and the filters used for the reception of the simultaneous range are no exception to this rule. The filter characteristics are shown in Fig. 29. These characteristics are not the best that could be secured were it desired to pass only 1,020 cycles for one filter and all frequencies

except 1,020 cycles for the other. A filter with a cutoff characteristic that is too sharp cannot be tolerated for the range tone-passing filter. This is because a sharp filter gives rise to transients that produce a ringing sound in the headphones whenever the filter is subjected to static or shock excitation of similar character. Ringing so severe that it is impossible to distinguish the *A* from the *N* signal has been observed with a

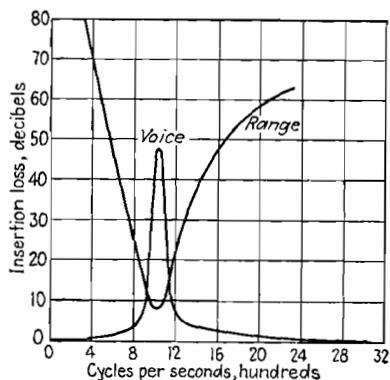

FIG. 29.—Characteristics of the filters used for simultaneous radio-range reception.

filter having characteristics that were too "good." The combined weight of the two filters is usually less than 3 lb.

The Simultaneous-range Transmitter.—Since this is the most common transmitter used in this country and is somewhat unusual in design, a description will be given here. It actually consists of two transmitters in a single frame. Both transmitters are crystal controlled by a

matched set of zero-temperature-coefficient crystals that assure a frequency separation of 1,020 cycles between the two carriers at all times. The weather transmitter has a power output of 400 watts and is capable of being modulated 70 per cent with voice. This transmitter is connected to the center tower.

The transmitter that furnishes (in effect) the single side band is unmodulated and has a power output of 275 watts. Two transmitters, as described, are used in each station and are so arranged that either can be connected to the antenna system in the event of failure of one unit. A goniometer unit common to both transmitters is used, but it is equipped with duplicate keying systems to guard against failure.

Visual Radio Range.—A long-wave visual radio range was developed by the Bureau of Standards in about 1928(10, 11). Some equipment of this type was purchased and installed but was later removed from service. Although none of these devices are in use today, the engineering associated with this development had many unusual features which are interesting. The transmitter consisted of two radio-frequency amplifiers each connected

to crossed-loop antennas similar to those described earlier in this chapter. The two amplifiers operated on the same carrier frequency but were modulated with different tone frequencies. The tone frequencies actually used were 65 and $86\frac{2}{3}$ cycles per second. These frequencies were chosen because they are not harmonically related. As was discussed under Course Shifting and Bending, the energy emitted simultaneously from various radiators will combine to form a space pattern; hence, if the methods discussed in that chapter are applied to the energy from the two loops, it will be seen that the resulting space pattern is again a figure 8, but located with its maximum vector 45 deg. to the plane of the loops. As the two amplifiers were modulated, however, side-band frequencies were present. These were

$$\begin{aligned} F_c + 65 \\ F_c - 65 \\ F_c + 86.7 \\ F_c - 86.7 \end{aligned}$$

In these expressions F_c is the carrier frequency. Two of the terms represent the upper whereas the other two are the lower side bands. Since these four frequencies are not identical, they will not combine in space but will form a normal twin figure 8 pattern in space. The carrier wave, however, is necessary regardless of the position of the receiver from the antenna in order to properly detect (demodulate) the wave. A circular field-strength pattern for the carrier wave is desired, while the side-band patterns should be two figure 8's at right angles to each other. In order to accomplish this, a common oscillator was used for both amplifier channels; however, a network shifting the phase of the exciting voltage to one amplifier was used. The results were two waves of equal magnitude and frequency but with a 90-deg. phase difference between them. When energy from the two loops is added vectorially for every position about them but with 90-deg. displaced vectors, the resulting pattern will be a circle; that is, the carrier-wave pattern is equal for all angles about the loop. If an airplane is flying at an angle of 45 deg. to the planes of the loops, the received side bands will be equal for 65 and 86.7 cycles, and equal quantities of both

tones will be present in the headphones. Coils similar to those used in headphones were connected to the output of the radio receiver(12). Above the pole pieces of these coils were placed spring strips of metal about 4 in. in length. One end of these metal strips, or "reeds," was attached to a rigid support, whereas the other end was free. The free end was bent to form a small flag which was painted white. Two of these metal strips were supported above the receiver coils. The mass and elasticity of these metal strips were so adjusted that they had mechanical resonant periods of 65 and 86.7 cycles per second. As the various side bands were received, the corresponding reed end vibrated to form a "blur." The amplitude of this blur was proportional to the received signal strength. When both sets of side bands were received with equal intensity, the blurs had equal amplitude. The fact that the airplane was flying in the direction of the plane of one loop more than the other was indicated by the relative amplitudes. The maximum amplitude was also an indication of the proximity of the airplane to the radio station. Because the reeds were very sharply tuned, they were unappreciably affected by static. The accuracy of the applied frequency had to be correct to within 0.05 cycle in order to actuate the reeds properly.

A further modification(13), interesting from an engineering standpoint, was designed. This consisted of adding a third amplifier to the system described above. The common oscillator was connected to the amplifiers by means of three phase-shifting networks (one per amplifier) so that the carrier frequencies at the output of each amplifier had a 120-deg. phase displacement. This third amplifier was modulated with a 108.3-cycle tone, whereas the other two amplifiers were modulated with 65 and 86.7 cycles, respectively, as described above.

The antenna system consisted of the two crossed loops, but these were connected to a goniometer having six secondaries. In pairs, these secondaries were mutually perpendicular to each other. Three of the secondaries were connected in series and fed one of the loops, whereas the other three were also connected in series to serve the second loop.

The goniometer had one primary for each pair of secondary coils. These primary coils were physically displaced 120 deg. with respect to each other, and each amplifier was connected

to one of the primaries. In space, the carrier frequencies from the two loops combine to form a pattern resembling (roughly) an ellipse. The side bands form three figure 8 patterns. The angle between the major axis through these three figure-8 patterns was 60 deg. These patterns have 12 intersections where the signal intensity from two sets of side bands is equal; hence, this range has 12 courses. Reception of this range is accomplished with a receiver similar to that used to receive the visual range previously described, except that the indicator has another 65-cycle reed and a 108.3-cycle reed. The added 65-cycle reed is merely for ease in making it possible to compare the relative amplitude of one tone with any other tone.

The four-course visual range was actually installed for airway use, but the twelve-course range was never placed in service. The four-course range was found to be subject to several defects which, although they might have been corrected, were instead converted to the aural type. One of the defects was caused by the use of two amplifiers. If the power output of one of these amplifiers changed, the courses would change. This is not true for the aural range, since a change in transmitter power output would affect both the *A* and the *N* field patterns equally. Another difficulty experienced was with the tuned reeds. Apparently they lost their calibration in service. It is interesting to note, however, that the desirability of a visual indicator was realized as early as 1927 (about the time that the first aural-type ranges were installed for service). The latest thoughts with regard to visual ranges will be discussed in the next chapter.

Geographical Coverage of Radio Ranges.—In order to know what spacing (in miles) to use between radio ranges, or, the corollary, what power to use in order to cover a given distance, it is necessary to compute the field strength produced at a given distance by a radio range. There are a number of formulas that may be used for solving this problem. All these are composed of three parts. The first part can be termed the power-output expression. This is that part of the formula which is concerned with the number of watts from the transmitter and the efficiency of the antenna. The next section can be called the natural-diminution section. The intensity of the radio wave (and many other natural phenomena) varies inversely as the distance from the transmitter. The third term contains

attenuation factors which are a function of the electrical characteristics of the terrain.

The terrain factor does not enter into calculations made for distances of 1 mile, and since this point is beyond the range of the induction field, it is convenient to base the first portion of this calculation on the mile distance. This portion of the formula was already given by Eq. (23)

$$E_f = \frac{234Ih_e}{\lambda} \quad (23)$$

In the section under antennas, the effective height of the range tower was given as 16.1 meters, but this must further be modified because of the two-tower configuration. The two-tower correction applying only to calculations of field strength 45 deg. from on course is a function of the tower spacing and is given by (14)

$$h_{er} = h_e \left(1.414 \sin \frac{\pi d}{\lambda} \right) \quad (49)$$

where h_{er} = corrected effective height

h_e = effective height of tower

d = spacing between towers

λ = wave length, meters

A further correction must be made to take care of the side-band characteristic of the simultaneous radio range as follows:

$$K_m = \frac{0.212K_1}{K_2 \sin \left(\frac{\pi}{\lambda} d \cos \theta \right)} \quad (50)$$

where K_m = factor by which the field strength is measured to account for the modulation characteristics of the range

K_1 = square root of the ratio of unmodulated to modulated transmitter power capacity

K_2 = ratio of side band to carrier amplitude resulting from attenuation by sharply tuned antenna circuits

For the conventional range, K_1 equals 1.22 and K_2 was calculated to be about 0.6. $\cos \theta$ refers to the point of measurement as discussed in the paragraph under range theory.

The current in the base of the antenna expressed by I in Eq. (49) is a function of transmitter power and efficiency as well as tower resistance; thus

$$I = \sqrt{\frac{P \cdot \text{eff}}{R}} \quad (51)$$

The resistance of the towers was given as about 1.5 ohms. The efficiency of the coupling system is subject to many variables, but since the resistance of the tower is so low, even the best inductances that can be constructed will have a resistance equal to or higher than that of the tower; hence, efficiency cannot be expected to be much more than 50 per cent.

The natural diminution factor can be easily applied merely by dividing the field strength secured by Eq. (23) by the distance in miles from the transmitter to the point for which the field strength is to be computed.

A number of methods have been worked out for computing the terrain factor, but for the longer waves the most consistent of these, when checked repeatedly by actual measurements, appears to be the van der Pol formula. This formula gives a factor S by which the field strength computed, as described above, must be multiplied in order to obtain the actual value. Factor S is given by(15)

$$S = \frac{2 + 0.3P}{2 + P + 0.6P^2} \quad (52)$$

or where P is greater than 20 by

$$S = \frac{1}{2P} \quad (53)$$

P is given by

$$P = \frac{0.842r}{\lambda^2 \sigma \times 10^{15}} \quad (54)$$

In this expression, r = distance from transmitter, miles

λ = wave length, kilometers

σ = soil conductivity, electromagnetic units

No account is taken of the dielectric constant of the soil, but this causes no appreciable error for range frequencies.

The Federal Communications Commission has a large amount of data dealing with soil conductivity. Table I gives values of conductivity for various types of soil.

The field strength from a typical radio range was computed and plotted in Fig. 30 by using two extreme values of soil conductivity. Experience has shown that a field strength of at least 50 μv per meter is necessary in order that satisfactory reception of range signals under conditions of heavy static may prevail. Figure 30 would indicate that this was possible for

TABLE I*

Terrain	Soil type	Difference in elevation, ft.	Conductivity, e.m.u. $\times 10^{15}$
Sea water.....			10,000
Fresh water.....			5,000-8,000
Marsh.....	Loam and silt		1,000
Flat or gently rolling..	Black loam	50	150-200
Rolling.....	Loam and sandy loam, loam predominating	50-100	80-100
Rolling.....	Sandy loam predominating	100-500	60-80
Hilly.....	Gravelly, sandy loams and rocky loams	500-800	40-60
Suburbs and small towns.....			30-40
Hilly.....	Gravelly, sandy loams and rocky loams	600-1,000	30-40
Flat or hilly.....	Sand and shale		25-40
Very broken.....	Gravelly, stony land	300-1,000	20-30
Residential sections....			20-30
Mountainous.....	Stony land	1,000-1,500	10
Broken mountainous...	Stony land	1,000-8,000	5-7

* Reprinted by courtesy of the RCA Manufacturing Company, Inc.

distances up to 65 miles only, for soils of low conductivity and up to 210 miles for soils of high conductivity. Actually, there is another factor not accounted for by this formula but which will be discussed in Chap. X. This is the important ionosphere factor which gives greater signal strengths, but chiefly at night. The usual practice is to locate major radio ranges at intervals of 200 miles, although some low-power ranges are often placed at intermediate points.

The Range Receiver.—In order to obtain the directional guidance offered by a radio range, it is necessary to carry only an

appropriate receiver and attach it to a suitable antenna located on the airplane's exterior. The output of the receiver comes through a filter (previously discussed) if reception is to be from a simultaneous-type range, but the conventional range delivers its message to a pair of headphones. The engineering features of this receiver will now be discussed. The receiver is, of course, of the superheterodyne type. The antenna characteristics will

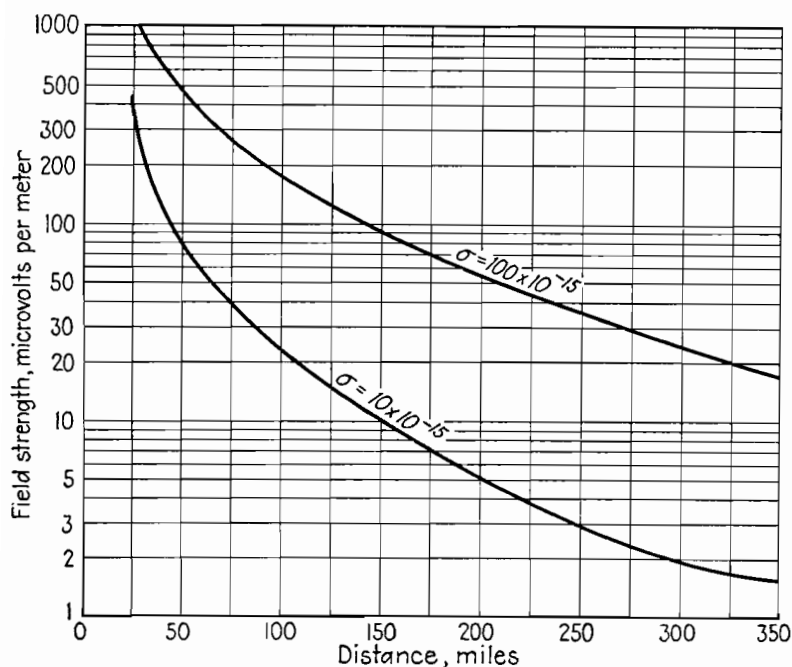

FIG. 30.—Field strength of radio-range signals for two types of terrain.

be discussed more fully later, but as would be expected the antenna is short compared with the wave length of the energy it is designed to receive; hence, it acts like a pure capacitive reactance over the entire range band of 195 to 415 kc. This antenna is usually connected directly across the first tuned circuit in the receiver. The first circuit must be designed for high amplification, as the desirable signal-to-noise ratio is usually specified as 6 db with an input of only $1 \mu\text{v}$ and 30 per cent modulation. The first circuit of a range receiver is usually that of a first radio-frequency amplifier. This is necessary because the

desired image-frequency suppression (in order to eliminate interference from broadcast and marine stations) is 100 db. The oscillator should be stable in order to meet the temperature requirement previously specified.

The use of tubes performing both first detector and oscillator functions has proved practical. The oscillator is (on a percentage basis) operating at a frequency far removed from the carrier frequency, so no interlock difficulty is experienced. Intermediate frequencies of both 90 and 180 kc. have been used. A selectivity of a high order is required for avoiding interference from stations separated by only 3 kc., so two stages of intermediate frequency

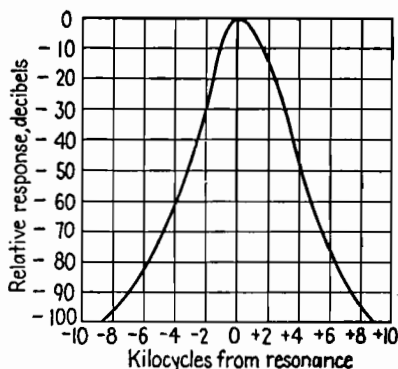

FIG. 31.—Selectivity characteristic of a modern radio-range receiver.

amplification are necessary. The desirable selectivity provides a band width of only 7 kc. when the attenuation (compared with maximum response) is 20 db. Suitable selectivity characteristics are shown in Fig. 31. Sensitivity is automatically of a high order when the selectivity requirements are met. It is usually specified that not more than 1 μ v of 30 per cent modulated input is required in order to produce 50 mw. of audio output over the entire band. The reason given for demanding this high sensitivity was that the receiver should still behave in a satisfactory manner even though it was necessary to operate with a very low-voltage battery (in event of generator failure).

The design of the second detector must be carefully considered because in this detector the audio signals from a simultaneous type range are actually generated. Every effort should be made to obtain a detector with an output directly proportional

to the input. The usual detector employed is of the diode type, which is generally considered to be linear, but additional effort spent in adjusting biases on this tube is necessary in order that the effect of the curvature in the detector-tube characteristic may be reduced and hence eliminate the cross talk between the weather and range signals. In Fig. 32 is shown the phenomenal difference in results between using a linear and a square-law detector.

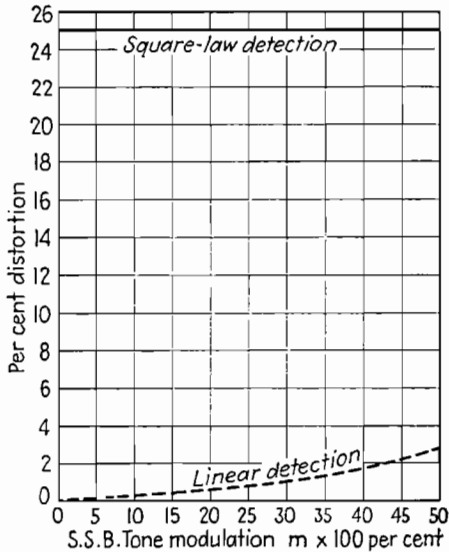

FIG. 32.—Effect of square-law and linear detectors on the reception of simultaneous radio-range signals.

The weight of receivers of this type, including a high-voltage dynamotor for plate power supply, should not exceed 22 lb.

Obviously, with such excellent selectivity, it is impossible to secure good quality. The frequency response is seldom flat within 4 db from 200 to 2,000 cycles. A typical response is shown in Fig. 33. After examining this figure, it is natural to question whether or not sufficient intelligibility remains upon subtracting the response of the filter of Fig. 29. This phenomenon bears testimony to the fact that although a monotone may be unpleasant to the ear, it is all that is necessary in order to convey intelligibility. The sharp selectivity serves to exclude static and, hence, aids in making the range signals easily read.

The successful interpretation of these signals is, after all, the most important function of the range receiver.

Automatic volume control serves to widen the course even when used with a simultaneous range which always has an uninterrupted carrier frequency. But since it is necessary to follow a range from directly over a station where the field

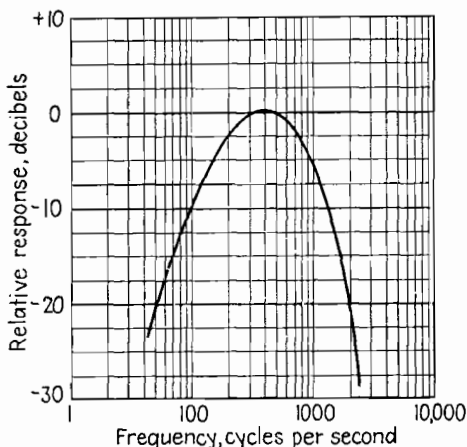

FIG. 33.—Audio response of a modern radio-range receiver.

strength is more than $50,000 \mu\text{v}$ to a distance of more than 100 miles where the field strength is $50 \mu\text{v}$ or less, an effective control of gain must be provided by controlling physiological factors. This consists in providing a rather large audio power output, so that the operator must reduce his receiver gain as the station is approached, because of the aural discomfort. This is a very important consideration. If the gain control is not effective, the first stage will overload, then the signal (*A* or *N*) that is stronger in space will be weaker in the headphones, while that which is weaker in space will be stronger in the headphones; the course will therefore apparently reverse in space, and it will be impossible for the pilot to work out his orientation problem correctly and locate himself before coming through the overcast.

Range-receiver Antenna.—Although the antenna used for range reception on aircraft appears to be a simple structure, it will cause course errors unless designed consistent with certain

principles. This fact was recognized as early as 1918 by the men who developed the range. W. H. Murphy of the Army showed by trigonometry that this error was caused by the projection of the antenna's horizontal dimension on the loop, and he developed a formula for course error. His paper(17), published in 1927, gave a curve for antenna error which is reproduced in Fig. 34. In this curve, β is the angle of sight, and a_2 is the angle of the antenna slope. In this figure it is clearly seen that the error can be reduced to zero only if the antenna slope is

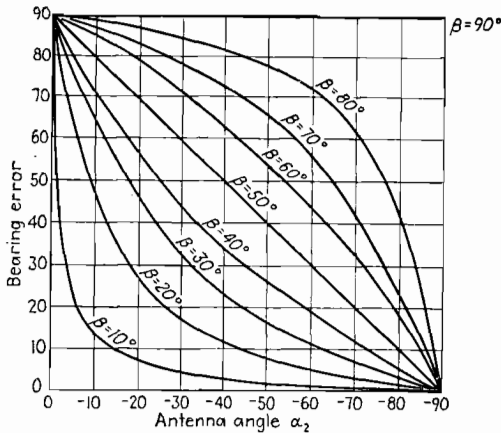

FIG. 34.—Variation in bearing error for various range-receiving antennas. (Reproduced with the consent of the Franklin Institute.)

90 deg., that is, if the antenna is vertical. It will be seen, however, that the error is the greatest as the airplane approaches the station (β approaches 90-deg.). For years the vertical antenna was used. This consisted of a self-supporting streamline mast with a cross section having a major axis up to 6 in. and a height up to 6 ft. This mast was located on top of the fuselage. The comparatively large height was necessary in order to secure sufficient pickup. The exact electrical characteristics of this antenna are not known, but they probably were equivalent to a condenser of about 30 μmf . Obviously, such a structure was not desirable from an aerodynamic standpoint. This mast was subject to icing and often vibrated vigorously when iced. In 1932, Diamond studied this problem(16), using a vector method of analysis. He developed a formula for bearing error that

closely resembled that previously developed by Murphy; however, he concluded that a flat top could be attached to the antenna if this flat top were symmetrical (as in a *T* antenna). He further found that this antenna was the equivalent in pickup to the vertical mast even though its actual vertical height was only a matter of 1 or 2 ft. He concluded that although the top section added nothing in so far as pickup was concerned, its loading contributed to increasing the effective height. Further comments relating to this increased pickup will follow later. It is believed that both these authors overlooked a factor that did not make itself evident until the advent of the present high-speed airplane. A great amount of maneuvering of airplanes always takes place near the radio station, and it is at this point that course bearing errors are important. With a high-speed airplane it is necessary to use rather steep banks, even in passenger service. These banks are usually less than 45 deg., but they may be as great as this figure. At this angle, then, the vertical mast has a 70.7 per cent horizontal component. Both the pure vertical mast and the in-line *T* antenna may produce course error.

A *T* antenna with the flat top across the line of flight in such a position that the vertical component increases during banks may be helpful, but such a structure is subject to icing. In 1932, United Air Lines developed a symmetrical *V* antenna which, although better than the crosswise *T* from an aerodynamic standpoint, still retains the ability to add vertical component as the airplane is banked.

This *V* antenna is spaced a distance of only 18 in. from the fuselage at the apex of the *V* and is very close to the fuselage at the extremity of the *V*. The lead-in comes from the apex. Each leg in the *V* is 85 in. in length, and the lead-in (to the fuselage insulator) is 75 in. The included angle between the sides is about 90 deg.

The total capacity of this antenna is about 90 $\mu\mu\text{f}$, and to this the lead from the fuselage insulator to the receiver adds 50 $\mu\mu\text{f}$. These antennas can be considered as generators having as their internal impedance, impedances equal to the capacitive reactance of the antennas, and having shunted across their terminals the lead-in capacity. It can be seen that if the capacity of the vertical mast had been of the order of 30 $\mu\mu\text{f}$, and the lead-in capacity

had been $50 \mu\mu\text{f}$, the antenna voltage would have been drastically reduced before the radio receiver was ever connected to it. Recent measurements on a vertical antenna made of a 6-ft. length of $\frac{5}{16}$ in. diameter steel showed it to have a capacity of only $15 \mu\mu\text{f}$. This antenna would deliver very little of its induced voltage to its receiver if the lead-in had a capacity of $50 \mu\mu\text{f}$.

In adding a flat top section to the short vertical antenna, the effective internal impedance of the generator is lowered. If it

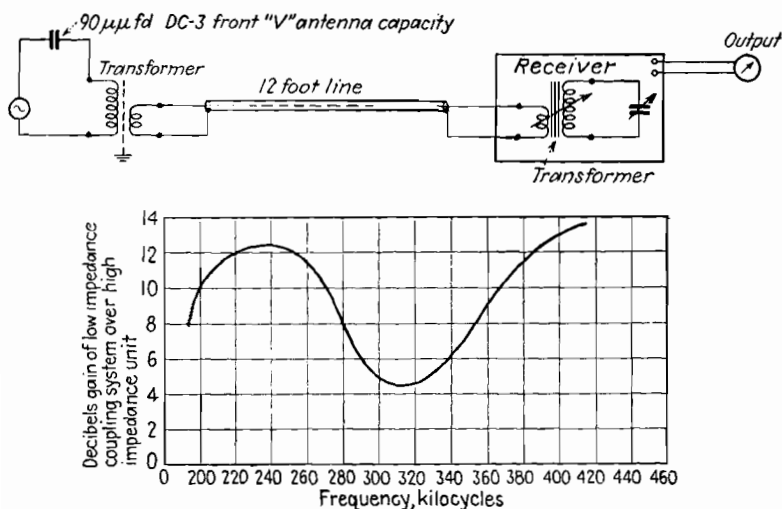

FIG. 35.—The low-impedance coupling system for radio-range-receiving antennas.

can be lowered to the point where it is small when compared with the shunt lead-in capacity, there will be no appreciable voltage loss by adding the lead-in.

With the development of iron cores for radio-frequency transformers, it has been possible to eliminate some of the lead-in loss by the use of these transformers. A transformer is located at the fuselage insulator, which in effect reduces the antenna impedance to a low figure. The secondary of this transformer is connected by means of a low impedance shielded coaxial transmission line to the primary of another transformer in the receiver. Here the impedance is stepped up and connected to the grid of a tube. Figure 35 shows the performance of such a transformer as compared with a lead-in. Measurements were made both in flight and in the laboratory. It will be seen that the gain in

favor of the transformer is never less than 5 db and may be as high as 10. In addition, these transformers are shielded and should be an important factor in keeping ignition interference out of the receivers. The high-impedance leadin has always been subject to ignition noise, (1) because it was high impedance and hence small coupling of noise to it was appreciable, and (2) because it could not be shielded, otherwise it would have produced too great a signal loss. It will be noticed that the antenna transformer in Fig. 35 has included within it an electrostatic shield between primary and secondary.

The number of antennas on the airplane has increased, and in an attempt to simplify the antenna structure there have been some installations of a small-diameter vertical mast located below the fuselage. This should, of course, give no course error except when the airplane is banked. Because of its flexibility, the air stream bends it, and hence it has a horizontal component which may act to minimize course errors during banking.

Problems

1. A localizer is designed for use with triangular loop antennas. These antennas have a center pole 35 ft. in height and four short poles—one at each of the lower corners of the two loops, so that the lower wires are 5 ft. from the ground. The base of each triangle is 5 ft. above the ground and 60 ft. long. Design a complete coupling circuit for this range, specifying the values of each condenser and coil used, assuming that the tuning unit is connected to a 70-ohm transmission line.

2. The government allows a 1,000 μv per meter signal at 1 mile. Assume that the coupling unit is 50 per cent efficient, and compute the maximum permissible transmitter power of the range of Prob. 1.

3. A *TL* range with the goniometer phased as in Fig. 21 has the towers placed so that one is at each cardinal point of the compass. The north and south towers normally have antenna currents of 6 amp., and the east and west towers have normal currents of 4 amp. Compute the resulting courses.

4. Owing to a faulty insulator, the current in the east tower was observed to have fallen to $\frac{1}{2}$ amp. The output circuit was designed as has been described in this chapter. Compute the resulting field pattern, and discuss in detail what the pilot would hear under these conditions.

5. Over what distance is a localizer producing a 1,000 μv per meter signal at 1 mile useful if the soil is rolling with sand loam predominating and 20 μv per meter is considered the minimum useful field strength?

Bibliography

1. BASHENOFF, V. I., and N. A. MJSOEDOFF: The Effective Height of Closed Aerials, *Proc. I.R.E.*, June, 1931, p. 984.

2. BASHENOFF, V. I.: Abbreviated Method of Calculating the Inductance of Irregular Plane Polygons of Round Wire, *Proc. I.R.E.*, December, 1927, p. 1013.
3. BASHENOFF, V. I., and N. A. MJSOEDOFF: Effective Resistance of Closed Antennas, *Proc. I.R.E.*, May, 1936, p. 778.
4. EVERITT, W. L.: "Communication Engineering," p. 513, McGraw-Hill Book Company, Inc., New York, 1932.
5. MOULLIN, E. B.: "Radio Frequency Measurements," 2d ed., p. 418. J. B. Lippincott Company, Philadelphia, 1931.
6. STUART, D. M.: Circuit Design for Low-frequency Radio Ranges, *CAA Tech. Development Rept. 23*, p. 6, November, 1939.
7. PRATT, HARADEN: Apparent Night Variations with Crossed-coil Radio Beacons, *Proc. I.R.E.*, May, 1928, p. 652.
8. DIAMOND, H.: The Cause and Elimination of Night Effects in Radio Range-beacon Reception, *Eur. Standards Jour. Research, Research Paper 513*, Vol. 10, January, 1933.
9. JACKSON, W. E., and D. M. STUART: Simultaneous Radio Range and Telephone Transmission, *Proc. I.R.E.*, March, 1937, p. 314.
10. DELLINGER, J. H., and HARADEN PRATT: Development of Radio Aids to Air Navigation, *Proc. I.R.E.*, July, 1928, p. 890.
11. DIAMOND, H.: Applying the Double-modulation Type Radio Range to the Airways, *Proc. I.R.E.*, December, 1929, p. 2158.
12. DUNMORE, F. W.: A Tuned-reed Course Indicator for the Four and Twelve-course Aircraft Radio Range, *Proc. I.R.E.*, June, 1930, p. 963.
13. DIAMOND, H., and F. G. KEAR: A 12-course Radio Range for Guiding Aircraft with Tuned-reed Visual Indication, *Proc. I.R.E.*, June, 1930, p. 939.
14. HARRISON, A. E.: "Geographical Separation of Radio Range Stations Operating on the Same or Adjacent Frequencies in the 200-400 K.C. Band," *CAA Tech. Development Rept. 4*, January, 1938.
15. GHIRING, H. E.: A Field Intensity Slide Rule, *Broadcast News*, December, 1935, p. 26.
16. DIAMOND, H., and G. L. DAVIES: Characteristics of Airplane Antennas for Radio Beacon Reception, *Proc. I.R.E.*, February, 1932, p. 346.
17. MURPHY, W. H.: Space Characteristics of Antennae, *Jour. Franklin Inst.*, Vol. 203, pp. 289-312, February, 1927.

CHAPTER III

THE ULTRA-HIGH-FREQUENCY RADIO RANGE

In the previous chapter the radio range was discussed in detail, also some of its aberrations and their cures. There are, however, some phases of this irregular range behavior that have not yet been corrected. Tests with ranges operating on ultra-high frequencies, as well as theoretical considerations, indicate that the solution of certain of these problems lies in the use of the higher frequencies for the range facilities. In this chapter, then, the faults of the low-frequency range will first be discussed, then the ultra-high-frequency range technique which is at present undergoing development will be introduced.

Bent Courses.—The fact that the range operation was found to be hampered by certain phenomena does not mean that its use disclosed some hitherto unknown characteristics of radio-wave propagation. This was decidedly not true for the case of bent courses. This phenomenon was long known to marine operators who found, upon taking bearings on radio stations located at some distance from the sea coast, that the radio waves apparently “bent” as they reached the coast, so it was named the “shore effect”(1). This effect is experienced by airplanes flying in mountainous terrain. A particularly outstanding example of this effect, not because it is the most severe case existing in the United States, but because it can be so clearly observed, occurs in one section of the Allegheny Mountains where there are a number of parallel ridges separated, perhaps, by some 25 miles. By carefully following the on-course signal of the radio range, the path or area in which interlocked signals exist seems to bend each time the signals reach one of these ridges.

This phenomenon can be explained by the simple illustration shown in Fig. 36. Each dot in this figure represents a marching soldier. The column is marching six abreast on a road when they strike a muddy field. The speed of the first soldier to strike the field is slackened. This also occurs a moment later

to the second soldier, etc. The front of the column is skewed, and an observer would conclude that they are marching in direc-

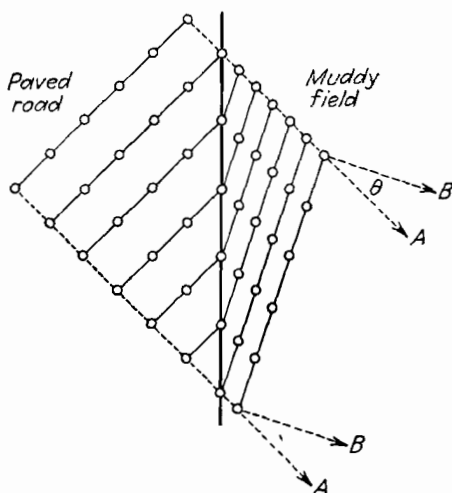

FIG. 36.—Skewing of the front of a marching column caused by increased impediment.

tion *B*, whereas they had formerly been marching in direction *A*. The same analogy can be applied to the bending of light waves and the index of refraction. It is necessary to caution against the extension of this analogy for, although the men would doubtlessly correct their direction of march in order to reach the desired destination, there is no force that prescribes such behavior for the radio wave. The direction of propagation of the radio wave is at right angles to the wave front; hence altered direction is inseparably associated with a skewed wave front.

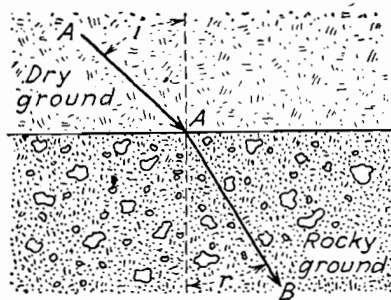

FIG. 37.—Bending of radio ray caused by differences in soil conductivity.

For mathematical purposes, this same phenomenon is shown diagrammatically in Fig. 37. In this figure a radio beam traveling in direction *AA* along dry ground reaches a boundary between

dry ground and an area of rocky ground. The beam makes an angle i with the normal to the boundary and then is bent so that it travels in the direction AB . The angle between the radio ray AB and the normal to the boundary is r .

Using optical theory [Snell's law(2)], the following expression may be written:

$$\frac{\sin i}{\sin r} = \frac{n_2}{n_1} \quad (55)$$

In this expression the angles i and r are the angles of incidence and refraction as shown in Fig. 37. The n terms are the indexes of refraction, that is, they represent the ratio between the speed of electromagnetic waves in a vacuum and in the given medium. The subscripts 1 and 2 refer to the indexes for the first and second mediums, respectively. This refractive index can be expressed by(3)

$$n = \sqrt{\frac{\epsilon}{2} + \sqrt{\frac{\epsilon}{4} + \left(\frac{2\pi c^2}{\omega}\right)^2}} \quad (56)$$

This expression is based on a wave traveling *through* a medium having a dielectric constant ϵ and a conductivity σ (expressed in electromagnetic units). The term c is the velocity of radio waves in a vacuum (equal to 3×10^{10} cm. per second) and $\omega = 2\pi f$ where f is the frequency of the radio wave in cycles per second. It is apparent that the course error can be expressed by

$$\sin^{-1} i - \sin^{-1} r \quad (57)$$

If a calculation of course error is made for a frequency of 300 kc. with the wave passing from dry ground with a dielectric constant of 4 and a conductivity of 1.18×10^{-13} to rocky ground with a dielectric constant of 4 and a conductivity of 1.18×10^{-14} , a value for $\sin i/\sin r$ of 3.35 results. If the angle of incidence was assumed to be 45 deg., then the sine of the angle of refraction will be 0.212, which corresponds to an angle of $12^\circ 15'$. The course error is

$$45^\circ - 12^\circ 15' = 32^\circ 45'$$

If the same computation is made and the same value for the dielectric constant and conductivity is used, but the frequency is assumed to be 100 megacycles, $\sin i/\sin r$ will equal 1.15, or

r will equal 38 deg. The course error is then

$$45^\circ - 38^\circ = 7^\circ$$

The course error has been reduced by nearly one-fifth. Of course, the preceding calculation is not rigorous, because the radio waves travel over the ground rather than through the ground; however, the implication is clear—the use of the higher frequency should reduce course bending.

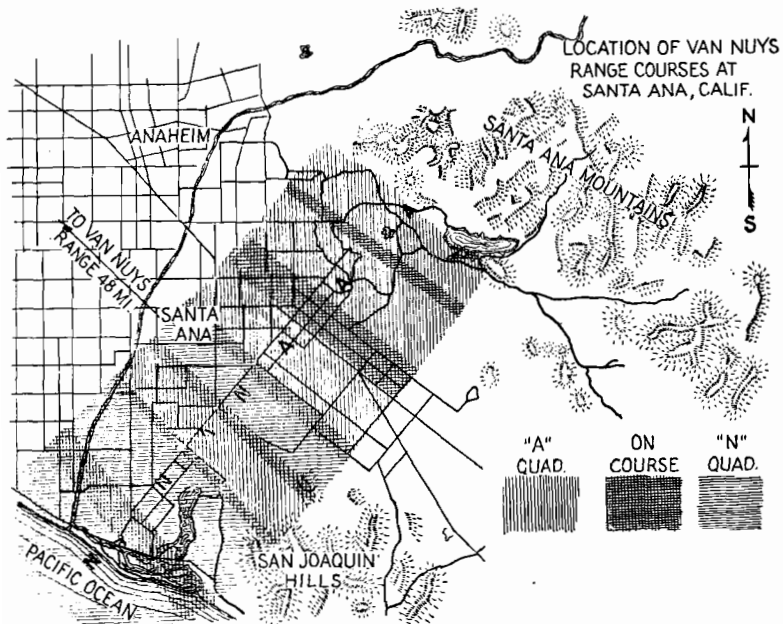

FIG. 38.—Plan view of multiple low-frequency range courses produced by mountainous terrain. (Courtesy of C.A.A.)

Multiple Courses.—The aberrations characterizing the transmission from a radio range in mountainous terrain which are most noted by pilots are the multiple courses. When flying at right angles to the range course, on-course signals will be heard in several places, interspersed with A and N zones. This phenomenon is clearly shown on the map of Fig. 38, which is the result of a study of the Van Nuys range located near Santa Ana, Calif. Another peculiarity of these multiple courses is that they do not remain constant for all altitudes. This is pictured in the elevation drawing of the range shown in Fig. 39. These

multiples can be attributed to the presence of vertical surfaces in the vicinity of the radio range.

In Fig. 40 are shown the lobes of a radio range located at point *R*. The line *M* represents the plan view of a vertical surface (such as a wall). The maximum ray from the *A* lobe (marked *A*) strikes the vertical wall at point *P*. Although its energy is diminished by this wall, it is nevertheless reflected back with considerable strength. This reflected ray is shown

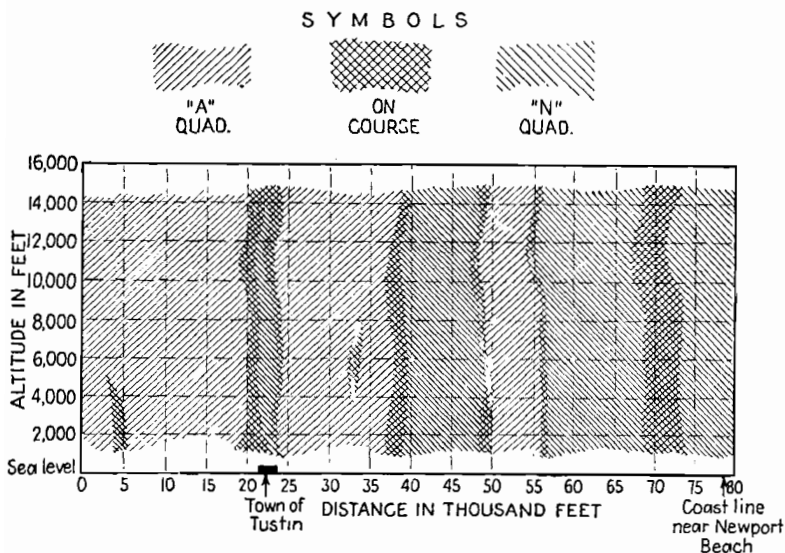

FIG. 39.—Cross section of multiple courses from Van Nuys radio range taken near Santa Ana. (Courtesy of C.A.A.)

as *A*. In its travel away from the vertical wall it meets other energy propagated directly from the range. It meets, at point *B*, a ray consisting of more *A* than *N* signal, but the *A* energy is less than the direct *A* ray which struck the wall. In the process of reflection, the phase of the *A* ray is changed. It is further changed by the relative distance that it travels in reaching point *B* as compared with the shorter distance traveled by the *AN* ray. At point *B*, then, the reflected *A* ray may diminish the amount of *A* energy in such a manner that it will be equal to the *N* energy and, hence, produce an on-course signal at this point. At point *C*, for a certain phase, it may cause the signal to be predominantly *N* rather than equal *A*

and N . The direct ray marked NA is composed of more N than A energy, but the phase of the reflected A energy at this point may be such as to add to the direct A ray and cause the amounts of A and N to be equal and therefore cause an on-course at point D .

The preceding explanation has been based on the reflection of a single ray; however, the energy for a few degrees on either side of the maximum A ray will act similarly to the maximum

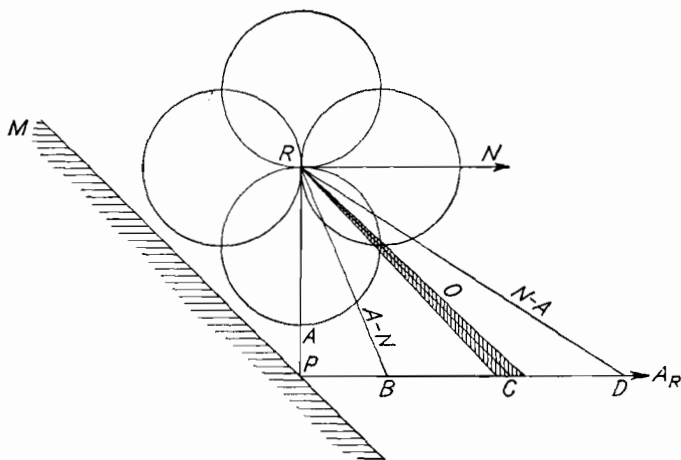

FIG. 40.—Energy from a radio range striking a vertical wall from which it is reflected. After reflection, it combines with energy coming directly from the radio range to form multiple courses.

ray, and an area, rather than a point, will be present in which the phenomena described will occur. The angle at which the A ray strikes the wall was chosen to have a large value; however, this angle can have any value, and it can be readily seen that signal patterns of any description can be produced by the proper choice of angles and distances to the wall.

If now there is substituted for the vertical wall a mountain that is not perfectly vertical but has a definite slope, there will be some elevation where the phase is such as to cause the direct and reflected rays to add, whereas at other elevations subtraction will take place, the result being the pattern shown in Fig. 39.

From the foregoing explanation of this phenomenon it would appear that the only freedom from these multiple courses would lie either in the impractical conditions of having no vertical

reflecting surfaces or in the use of radio waves that are not capable of being reflected. It will be noticed in the preceding explanation, however, that the phase of the wave determines the nature of the multiple signal. This phase changes by 180 deg. every half wave length; hence, a multiple of a given character on the course of a radio range operating at 200 kc. can hardly exist over a distance of more than 2,430 ft., or approximately $\frac{1}{4}$ mile. If, however, the frequency had been 125 megacycles, this same multiple would extend over a distance of only 3.9 ft. An airplane

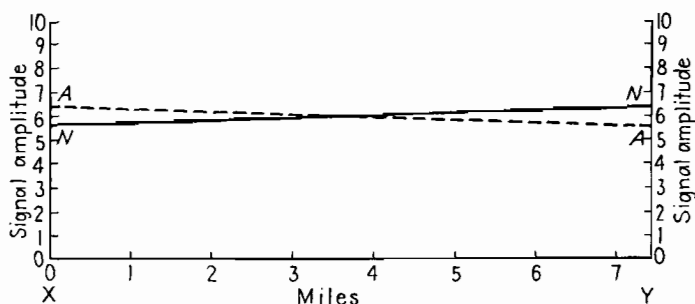

FIG. 41.—Theoretical field strength of the A and N signals in a section of terrain 7.4 miles wide across the course of one leg of the Pittsburgh radio range. (Courtesy of Institute of Radio Engineers.)

flies over a distance of this extent in such a short time that the multiples are not readily discernible. These multiples appear only as modulations of the main signals.

Another characteristic of the ultra-high frequencies which helps in eliminating multiples is the peculiarity of propagation (as will be discussed in detail later) which dictates that the largest portion of the signal comes, not via the ground, but directly to the airplane. The reflected signal traveling nearer to the surface of the earth than the airplane will have an amplitude much lower than the signal that travels directly to the airplane; hence its addition or subtraction to or from the direct wave will have but a small effect on the resulting character of the signals.

Experimental Results.—Some tests of the principles set forth above have been made(4), and the conclusions to date indicate that a solution may be at hand. Figure 41 shows the theoretical value of the A and N signals across a section at right angles to

an on-course. The section is assumed to have a length of 7.4 miles and be located 52 miles from a radio range. The center of this section is the location of the true on-course. Measurements of the relative strengths of these *A* and *N* signals were then made in a section corresponding to that previously con-

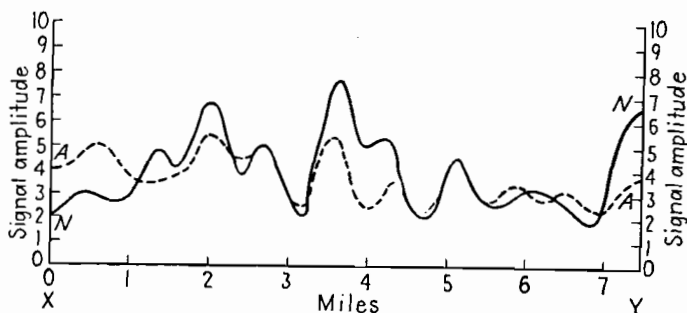

FIG. 42.—Actual field strength of the *A* and *N* signals measured for the range course of Fig. 41. The range operates on a frequency of 254 kc. (Courtesy of Institute of Radio Engineers.)

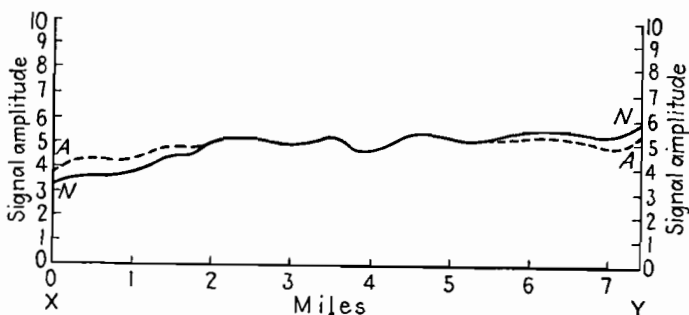

FIG. 43.—Actual field strength of the *A* and *N* signals measured for a 63-megacycle transmitter. This transmitter was located near the transmitter, the characteristics of which are shown in Fig. 42. Measurements were made in the same area as those of Fig. 42. (Courtesy of Institute of Radio Engineers.)

sidered from a theoretical standpoint. The measurements were for a range operating on 254 kc. and located in the mountainous terrain near Pittsburgh, Pa. The results are shown in Fig. 42. This figure shows that the variation of the signal intensity is quite irregular, and in the area where the strength of the *A* signal should be greater than the *N*, the converse is sometimes true. In the areas where the *N* signal should have a strength greater than the *A*, the converse is also true for a certain portion of the

cross section. An ultra-high-frequency transmitter operating on a frequency of 63 megacycles was next erected near the low-frequency range, and measurements of its signal strength were made in the same area considered previously for the low-frequency range. The results are shown in Fig. 43. It can be seen that in this figure the relative strengths of the signals approach the theoretical relation shown in Fig. 41. Of great significance is the fact that signal-strength relations inverse to those which should hold for normal courses are not present.

Effects of Wave Polarization.—In using ultra-high frequencies, antenna systems may be so chosen that the radio wave is polarized predominantly horizontal or vertical. The proper choice

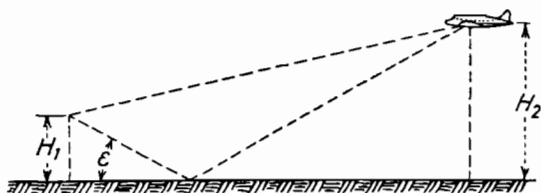

FIG. 44.—Transmission of ultra-high frequencies showing the direct and ground-reflected rays.

of polarization is important because of its effects on the behavior of space patterns. It is inseparably associated with propagation characteristics of these waves, so the mechanism of propagation is illustrated in Fig. 44. In this figure a transmitting antenna of height H_1 sends out a signal that is received by a receiving antenna of height H_2 . Two rays of energy reach this antenna. One of these rays travels directly from the transmitter to the receiver and is called the "direct wave"; the other ray reaches the receiver by reflection from the surface of the earth and is called the "ground-reflected wave." The total energy at the receiving antenna will therefore be the vectorial sum for two reasons. The first of these is that the lengths of the paths taken by the direct and the ground-reflected rays are not equal. This means that the energy coming via the two paths will have a phase difference that is a function of this path difference. The other is that there is a phase change upon reflection of the ground-reflected ray. There is also an amplitude change upon reflection. Under practical conditions, the earth is not a smooth plane but has many irregularities. This is true for propagation at

both long and very short waves; however, in order for a rough surface to act as a regular reflector, the following equation must be satisfied:

$$\frac{2H}{\lambda} \sin \delta \ll 1 \tag{58}$$

In this equation, H is the difference in elevation of the various points on the surface under discussion, λ is the wave length, and δ is the angle of incidence measured between the impinging ray and the surface. As the wave length becomes smaller, the term on the left side of the equation becomes larger, and therefore Eq. (58) is no longer satisfied. The surface, then, no

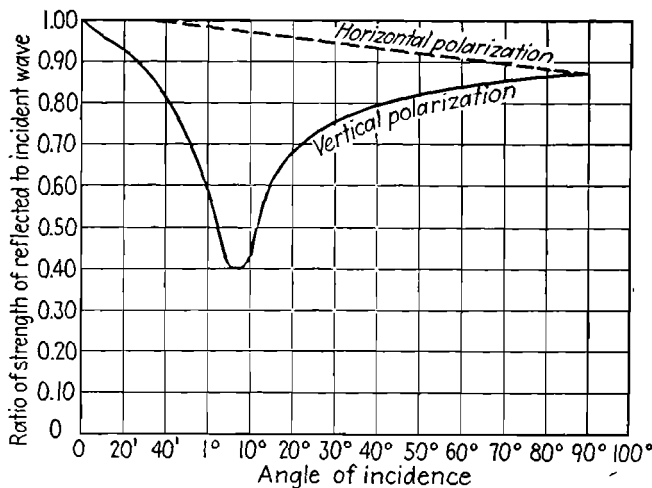

FIG. 45.—Ratio of strength of the incident to the reflected ray for various incident angles but for soil of a given conductivity and dielectric constant.

longer acts as a regular reflector, but many of the several points on it become separate reflectors and send back individual rays distinct from those reflected to the receiving antenna from other points on the surface. It is reasonable to assume that under these conditions the energy at the receiver will be composed of rays from many surfaces. If the rays from all these surfaces are not reasonably the same in intensity and phase, there will be considerable variation in the signals as the airplane travels along and receives energy from continually changing surfaces. For the case of reception of radio-range signals, the conditions become more exacting because there are two separate signals

that must be received, the intensity of which must be compared in order to determine the true course.

The changes in phase and intensity of the radio signals upon reflection have been computed(5) for terrain of various conductivity and for various angles of incidence. In order to

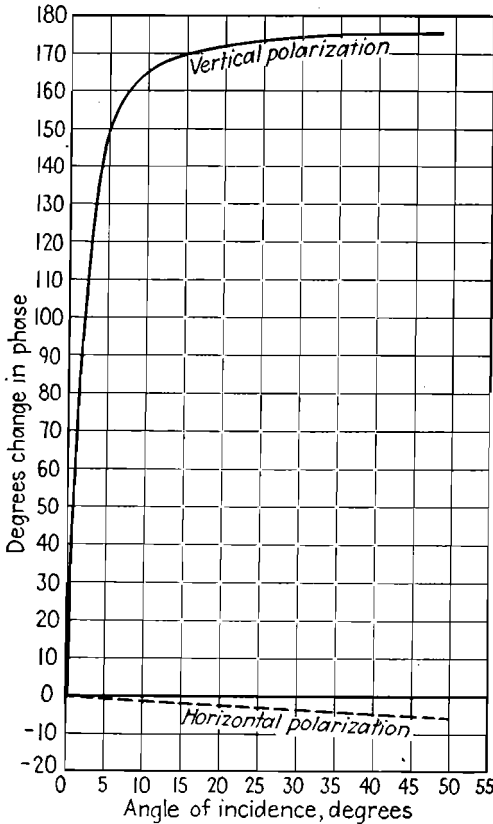

FIG. 43.—Change in phase between the incident and reflected ray for various incident angles but for soil of a given conductivity and dielectric constant.

illustrate the difference between horizontally and vertically polarized waves, Figs. 45 and 46 have been plotted using data previously referred to for various angles of incidence but for soil of a given conductivity. By referring to Fig. 45 it will be seen that for horizontal polarization the reflection coefficient of intensity varies from 0.87 to 1 as the angle of incidence varies from 90 deg. to 35 minutes; however, for angles less than 35

minutes there is no change in coefficient. For the same soil conductivity (and dielectric constant), but for vertical polarization, the reflection coefficient varies from 1 to 0.87 with variation in incidence angles from $\frac{1}{2}$ minute to 90 deg. The minimum coefficient, however, occurs with an angle of incidence of 6 deg.; here the value is 0.4.

By referring to Fig. 46, it can be seen that for horizontal polarization the change in phase of the energy at reflection varies from zero to minus 8 deg. as the angle of incidence varies from 3.5 to 50 deg. For vertical polarization, the change in phase is from approximately zero to nearly 180 deg. as the angle of incidence varies from zero to 50 deg. These data, it must be emphasized, do not represent the general case but hold true for soil of a certain dielectric constant and conductivity and are used only as a single illustration of the difference between the behavior of horizontally and vertically polarized waves.

From these curves it is evident that the variation in received signal intensity with varying angles of incidence will be greater with vertically than with horizontally polarized waves. That is, as the airplane moves with respect to the transmitter, thereby receiving energy from rays with various incidence angles, the intensity of the reception will vary more with vertically than with horizontally polarized waves. For minimum irregular course phenomena then, the horizontally polarized waves are to be preferred.

The Simple Ultra-high-frequency Radio Range.—An ultra-high-frequency radio range can be constructed rather simply, and a number have been built for experimental use. If a rod having a length equal to one-half the wave length of the radio wave that excites it is held horizontally, it will have a field-strength pattern in the horizontal plane which closely resembles the pattern obtained with the previously discussed low-frequency loop antenna. Two of these antennas may be located at right angles to each other, and if the energy to them is alternately connected and removed in such a manner as to form the *A* and *N* signals, an ultra-high-frequency radio range similar to the aural-loop type range will result. The impedance at the center of these antennas is about 72 ohms, so it can be easily fed with a low-impedance transmission line. In order to preserve the uniformity of the figure-8 field-strength pattern, it is necessary

that the current through both halves of the antennas be equal; therefore, the transmission line must be balanced electrically with respect to ground. An antenna system of this type emits horizontally polarized waves. It is shown diagrammatically in Fig. 47.

Following the theory previously discussed for the TL

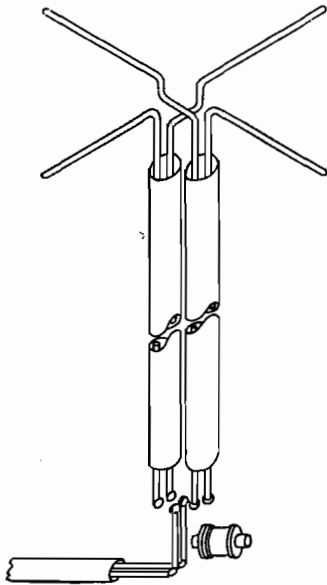

FIG. 47.—Antenna array suitable for aural ultra-high-frequency range transmitting horizontally polarized waves.

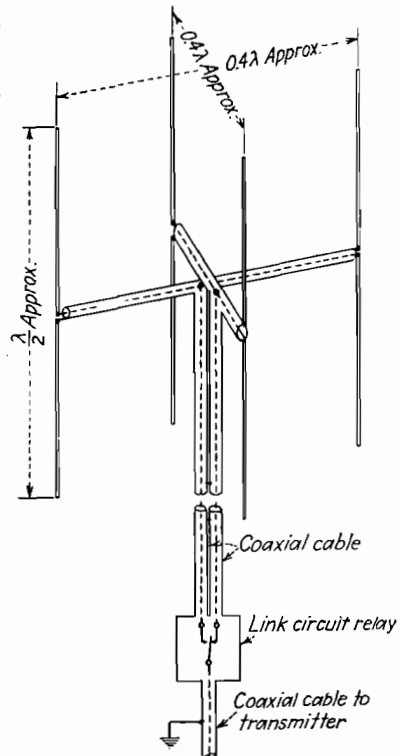

FIG. 48.—Antenna array suitable for aural ultra-high-frequency range transmitting vertically polarized waves. (Courtesy of C.A.A.)

range, it can easily be understood that two half-wave antennas(7) erected vertically and spaced approximately one-half wave length apart will produce a figure-8 field pattern, but the waves will be vertically, rather than horizontally, polarized. The use of this spacing assures the maximum field strength for a given amount of antenna current. The energy to these pairs of antennas is keyed at time intervals corresponding to *A* and *N* signals as before. Two of these antenna pairs are used to form the array for the *A* and *N* field pattern.

The power necessary to cover a given distance will be discussed in detail later. However, it has been found that a usable signal can be received at distances of 50 to 100 miles from the station with a transmitter power of only 100 watts if the altitude is in excess of 2,000 ft. above the terrain. Considering the results that are attainable with the simple system described, the economy of such a range over the low-frequency types previously described is outstanding. The cost of a complete simple ultra-high-frequency range would be less than that of a single low-frequency

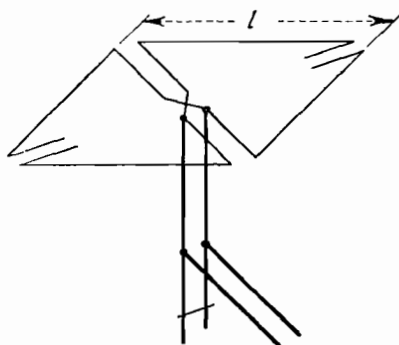

FIG. 49.—Alford transmitting type ultra-high-frequency loop antenna.

TL tower. A simple vertically polarized ultra-high-frequency range antenna array is shown in Fig. 48.

The Alford Loop.—As has been previously shown, the use of horizontally polarized waves is very important. It has further been stated that a horizontal dipole antenna is a source of horizontally polarized waves. This is true; however, a horizontal dipole remains somewhat sensitive to vertically polarized waves and, conversely, transmits waves that have a certain vertical component. An antenna free from these defects was invented by Andrew Alford in 1938. This device seems destined to play an important role in the application of ultra-high frequencies for aeronautical use(8).

This antenna takes two common forms. These are shown diagrammatically in Figs. 49 and 50. The antenna of Fig. 49 is commonly used for transmission and that of Fig. 50, because of its smaller dimensions, is used for reception. In both cases the length of the sides l is one-eighth wave length or less. The

folded ends of the antenna are so adjusted that the current maximum occurs in the middle of each side.

The field pattern of either form of antenna is the same in the horizontal plane and is identical to that of a vertical dipole (except that the loops are sensitive to horizontally rather than vertically polarized waves). The field pattern in the horizontal plane is essentially circular, whereas in the vertical plane it is a figure 8, the longest axis of which is horizontal.

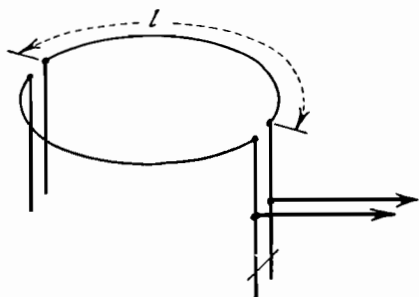

FIG. 50.—Alford receiving type ultra-high-frequency loop antenna.

The radiation resistance of these antennas is given by a quasi-empirical formula

$$R_a = 320 \left(\frac{\pi \sqrt{A}}{\lambda} \right)^4 \quad (59)$$

In this expression, A is the area expressed in square units similar to those used for λ , the wave length. This value for the practical antenna will vary from a few ohms for that of Fig. 50 to as high as 45 ohms for that of Fig. 49.

The efficiency of this antenna is, of course, the ratio between the radiation resistance and the ohmic resistance and has been found to be as high as 95 per cent for the form depicted on Fig. 49. The efficiency of this antenna has been measured to be identical with that of a half-wave dipole.

The input impedance of this antenna is largely reactive, so it must be fed by a resonant transmission line or a tuned circuit. The transmission line is preferred because it furnishes the best ratio of reactance to resistance and because it serves as a connection from the antenna without the necessity for locating the resonant circuit directly at the antenna. A complex arrange-

ment of these lines for multifrequency operation will be discussed later. Simple forms of this resonant line are shown in Figs. 49 and 50. The power lost by this coupling transmission line is given by

$$P = \frac{RV^2}{(Z_0 \sin 2\pi s/\lambda)^2} \quad (60)$$

where R = resistance of the line

V = voltage at its terminals

Z_0 = characteristic impedance of the line

s = length in units similar to those used to express the wave length λ .

From this expression it is evident that the power loss can be kept to a minimum by making R as low as possible and Z_0 as high as possible. This requirement, it can be shown, dictates the use of a transmission line having a ratio between conductor diameter and spacing of about 9.0. Another factor affecting line loss is the magnitude of the voltage on the line. For a given amount of power, this voltage can be made low by making the characteristic impedance of the antenna low. This requirement can be met by making the radiating conductors of wide strips of metal.

Aural Range with Loop Array.—With reference to Fig. 13 in Chap. II, it can be seen that the field strength on the course of the aural range is not the maximum voltage but is

$$E_{(on\ course)} = E_{max} \cos 45^\circ = 0.707E_{max}$$

That is, the on-course signal strength is approximately 2.7 db less than the maximum. To express this condition from a different point of view, since doubling the power of a transmitter increases the field strength by only 3 db, the field strength of the usual aural-range signal on course is but slightly greater than that produced by a transmitter of only half power at the maximum field-strength position. Since the on-course position signal of the radio range is the signal most used on the airway, it is undesirable to concentrate the maximum power in the position that is used the least. This situation has been discussed on various occasions, but the modification of this pattern for the low-frequency range was not readily feasible. The experimental ultra-high-frequency ranges that were installed between Chicago and New York in the summer of 1941 use the field-

strength pattern shown in Fig. 51. This pattern shows that the maximum energy has been concentrated near the on-course positions. The voltage 45 deg. from on-course is about 0.72 times that received on-course. The ratio of *A* to *N* signals 1.5 deg. off-course is a minimum of 0.34 db.

This very desirable pattern is obtained by using five Alford loops. All five loops are coplanar and spaced as shown in Fig. 52.

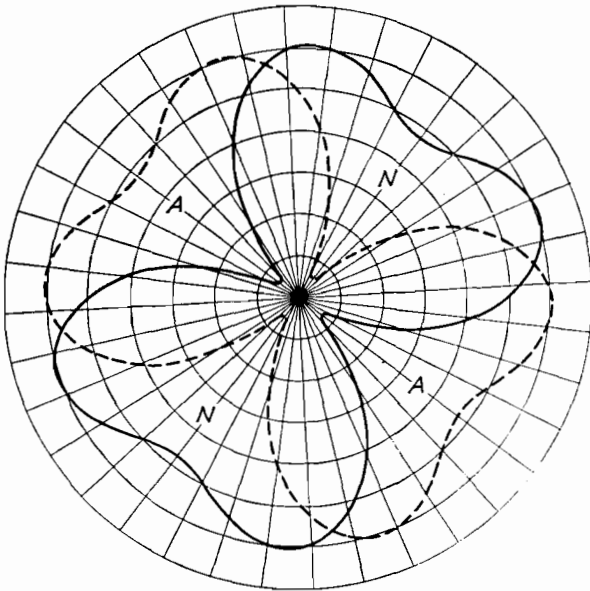

FIG. 51.—Field pattern of aural ultra-high-frequency loop antenna. (Courtesy of C.A.A.)

Two of these loops having a common phase are fed in parallel from the keying relay and furnish one of the signals. Their positions are such that 420 electrical degrees of spacing exists between them. The other signal is furnished from another pair of loops located so that a line drawn between their centers intersects a similar line from the first pair at 90 deg. A loop in the center remains connected to the transmitter at all times through a phase-shifting network. This network adjusts the phase of this center loop so that its field is 180 deg. out of phase with the field produced by the other loops. A further requirement is that the current in the center loop be twice that flowing

in the other loops. The keying is accomplished in the transmission line, standard equipment being used.

This antenna array is mounted on a steel tower about 30 ft. in height. At the top of this tower is a circular metal structure fitted with screen wire and thus forming a counterpoise. The diameter of this counterpoise is 35 ft. It is very important

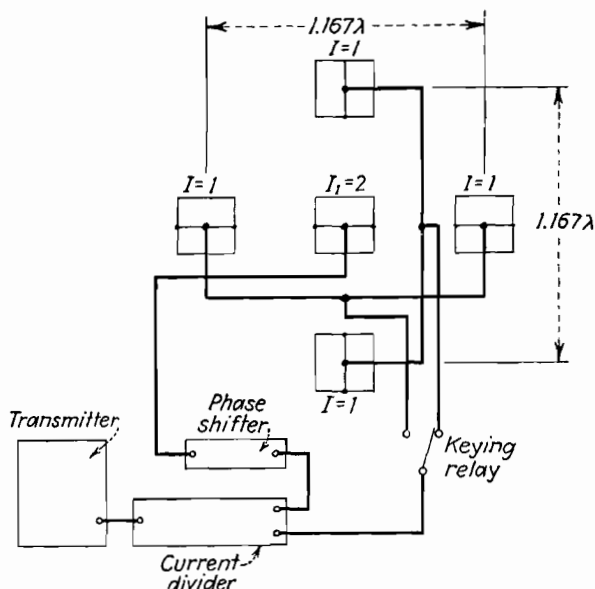

FIG. 52.—Five-loop antenna array used to produce the field pattern shown in Fig. 51. (Courtesy of C.A.A.)

that this counterpoise have a diameter at least equal to or greater than the height of the tower, otherwise there will be undesirable lobes of energy. The antennas are mounted so that they are $\frac{5}{4}$ of a wave length above the counterpoise. The entire antenna array is housed with a wooden structure. Because of its high dielectric constant, water seriously affects the reactance characteristic of these loops; however, the small air space between the antenna and the precipitation provided by a dielectric housing serves to eliminate this effect completely.

This antenna array is fed by copper transmission lines having two inner conductors separated from each other and from the copper pipe with ceramic insulators. The surge impedance of

the transmission line is 175 ohms. The entire line is constructed so that it is gastight, and it is kept filled with nitrogen in order to keep out moisture. Course rotation with this radio range is accomplished by simply rotating the entire antenna structure.

The transmitter is designed to give a power output of 300 watts in the range 123 to 127 megacycles. It is crystal controlled and uses a total of four stages of amplification and frequency multiplication. It is modulated 100 per cent by a 1,020-cycle note.

Visual Two-course Range.—Although a radio range operating at ultra-high frequencies designed to give aural indications similar to those received from the older low-frequency ranges is being tested in order to learn of the characteristics of the ultra-high-frequency ranges, it is realized that radio-range requirements have changed since the first ranges were designed. The aural range with its single course is hazardous when a large number of airplanes are simultaneously flying in a small area. The position of an airplane designated by the "right" and "left" side of a course is too indefinite when certain airways are being crowded by high-speed airplanes. The necessity for the pilots of these airplanes to work a "problem" in order to determine their positions and come through the overcast calls for a more direct facility. Commercial aviation is reaching the stage where every flight is handled in the same precise manner, and the necessity for extraneous maneuvering is incompatible with this type of flying. In the latest decision by the various representatives of flight groups a preference has been expressed for a two-course range with quadrant identification. Further, the decision has been to make the range indication visual.

Figure 53 shows a field-strength pattern somewhat similar to the pattern that is to be produced by this new type range. The area enclosed by the short dashed lines is the field pattern of a signal modulated by 150 cycles, whereas the solid line encloses an area in which a signal modulated by 90 cycles is present. These two signals are received on a radio receiver, the output of which is connected to two wave filters so designed that one passes 90 cycles while the other passes 150 cycles. After these two components have been separated, they are rectified and applied to two coils of a zero-center meter. The meter will indicate to the right or left, depending on whether the 150- or

the 90-cycle component is the greater. When the two components are equal, the indicating needle on the meter will remain in the center. The areas enclosed by the long dashed and dash-dot lines are areas in which a 1,020-cycle tone, keyed in two different manners, is present. This tone is separated from the output of the receiver by a third filter and applied to the

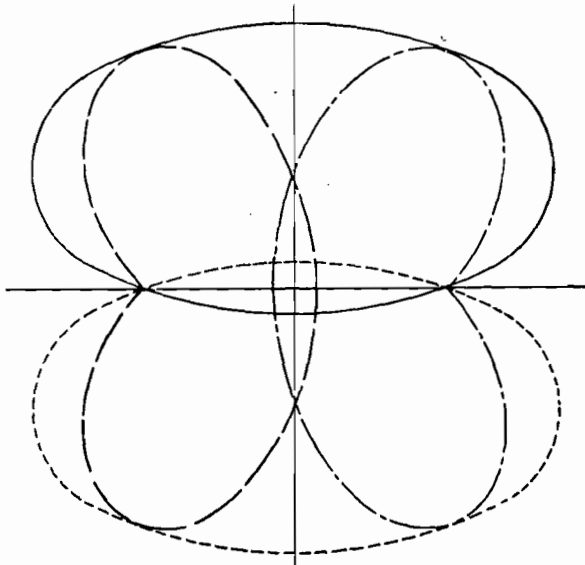

FIG. 53.—Field pattern of visual ultra-high-frequency range. The solid and dotted lines indicate the field strengths of the 90- and 150-cycle signals respectively. The pattern shown by the dashed and dot-dashed lines indicates the field strength of the keyed 1020-cycle signals.

headphones. The identifying signal produced by this tone indicates whether the airplane is approaching a station or has passed it. This indication, combined with the visual indication, instantly tells the listener the quadrant of the range in which he is located. It is intended that eventually two lines of these ranges will form an airway. One line of ranges will give the "go-to" guidance, and the other will give the "come-from" indication. The indication of this range can easily be converted to a means for actuating an automatic pilot, thereby relieving the human pilot of the necessity for manually guiding the airplane.

In order to obtain visual indication and not encounter the objections that were met in using the low-frequency radio range,

a single transmitter is used to generate all the radio-frequency power, and the various courses are developed by mechanical modulators. Unfortunately, technical details of this very interesting engineering development are not at this time available for publication.

The Omnidirectional Range.—Under development is also a range that gives the opposite performance to that of the two-course range discussed. Whereas the two-course range is intended to furnish restricted flying areas with signals that can be simply converted to automatic guidance, the omnidirectional range is designed to furnish indications over the entire area of reception. It has as its basis an old principle used for ship guidance. An explanation of the long-wave omnidirectional range will help in understanding the principle behind the new automatic ultra-high-frequency range bearing the same name.

If a loop antenna and a vertical antenna are energized simultaneously by radio-frequency power from the same course, but the phase of the current in one or the other (either one will serve) is shifted 90 electrical degrees, the resulting pattern will be a cardioid, provided that the effective heights of both antennas as well as their currents are equal. This same pattern can also be obtained by using two loop antennas and a vertical antenna. If the energy to the loop antennas is fed to them through a goniometer and its secondary is rotated, the cardioid rotates. If this goniometer is rotated by a synchronous motor in such a manner as to rotate the cardioid pattern 360 space degrees in 1 min., then in 1 sec. the pattern would move 6 deg. Besides rotating the goniometer, a mechanism was used so that every time the "null" of the cardioid passed through true north, the transmitter was automatically disconnected from the goniometer and simultaneously modulated by a distinctive tone. If an observer noticed the position of the second hand on his watch when he heard this distinctive tone and then noticed the seconds that elapsed from that time to the time the signal disappeared owing to the null passing by, he could multiply this time in seconds by six and obtain his bearing with respect to the radio-transmitting station. Watches were available having a face calibrated in degrees and a means for setting the second hand to zero when the distinctive tone was heard. This rotating cardioid pattern is shown in Fig. 54.

The RCA Omnidirectional Range.—Utilizing ultra-high frequencies and modern instrumentation to replace the mechanically rotated goniometer and stop watch mentioned as associated with the older art, the Radio Corporation of America has developed and demonstrated a new type omnidirectional radio range(9). It has been shown in the previous chapter that if two

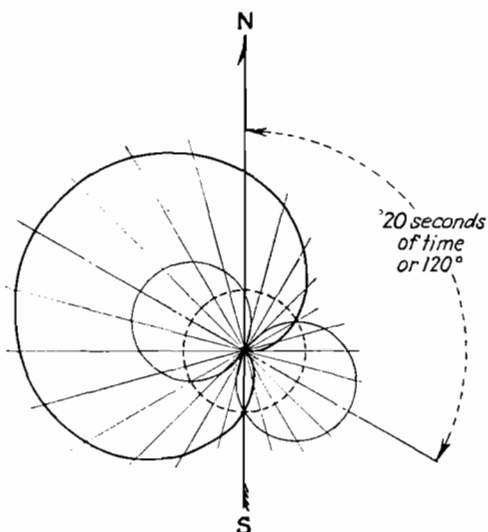

FIG. 54.—Cardioid field pattern from an omnidirectional radio range.

vertical radiators were fed out of phase with the same radio-frequency power, the field would be given by the equation

$$L_1 = L_{\max} \cos \theta \tag{61}$$

It is possible, however, to connect to these antennas only the side-band energy of a radio transmitter, employing apparatus known as a balanced modulator. If this is done the radio frequency in each antenna will vary with the audio frequency of the balanced modulator, or

$$L_{\max} = L_0 \cos (2\pi f_a t) \tag{62}$$

Substituting Eq. (62) in Eq. (61), the following expression results:

$$E_1 = E_0 \cos \theta \cos (2\pi f_a t)$$

If a second pair of vertical antennas were erected so that the

plane containing them was at right angles to the plane containing the above-mentioned set, then the field strength would be expressed by a modified form of Eq. (61), or

$$E_2 = E_{\max} \sin \theta \quad (63)$$

This expression was previously discussed for the long-wave range in Chap. II.

If this pair of vertical radiators were connected to a balanced modulator which is modulated by the same audio frequency as that used with the modulator connected to the first pair, and the phase of this audio frequency were retarded by 90 deg., the radio frequency in this second pair of antennas would be given by

$$E_{\max} = E_0 \cos (2\pi f_a t - 90^\circ) \quad (64)$$

or

$$E_{\max} = -E_0 \sin (2\pi f_a t) \quad (65)$$

Substituting Eq. (65) in Eq. (63), the following expression results:

$$E_2 = -E_{\max} \sin \theta \sin (2\pi f_a t) \quad (66)$$

The total field can be obtained by adding E_1 and E_2 as follows:

$$E_D = E_1 + E_2 = E_{\max} [\cos \theta \cos (2\pi f_a t) - \sin \theta \sin (2\pi f_a t)] \quad (67)$$

or

$$E_D = E_{\max} \cos (2\pi f_a t + \theta) \quad (68)$$

The field produced by a nondirectional antenna is everywhere (except very close to the antenna) at a 90-deg. phase relation to the field produced by the previously discussed directional elements. If this antenna is fed with radio frequency of the same general character as was used to excite the above-mentioned modulators, but phased to compensate for the 90-deg. space phase, the field from this antenna would add directly to that produced by the directional pairs, and the resulting voltage would be

$$E_T = E_N + E_{\max} \cos (2\pi f_a t + \theta) \quad (69)$$

If E_N equals E_{\max} , then Eq. (69) is that of a cardioid. The audio voltage at a given point in a horizontal plane reaches, from this equation, a maximum as a function of the angle θ . That is, it reaches a maximum as a function of the position

occupied by any particular point in space as a function of the relation between this point and the antenna array. In other words, there is achieved a cardioid that rotates in space at a speed equal to the velocity of the modulating frequency. The use of a relatively high modulating frequency (such as 1,000 cycles) produces a rotation of the cardioid pattern at a speed that could not be practically achieved with the rotating goniometer previously described. In this system, in addition to the provisions previously described, a method is included for momentarily stopping all transmission when the maximum of the cardioid reaches a true north position. The cardioid pattern is used in a modified form so that it has a flattened minimum side rather than a null. This is to permit the reference signal to affect reception regardless of the location of the receiver.

In the radio receiver, the radio frequency is detected in a conventional manner. The audio frequency is filtered and then connected to one set of deflecting plates of a cathode-ray oscilloscope. This same audio frequency is also connected to a phase-shifting network that produces a 90-deg. shift. The output of this filter is connected to another pair of cathode-ray oscilloscope deflecting plates. As is well known(10), this connection causes the cathode spot at the end of the tube to rotate in a circle at a speed which is directly a function of the audio frequency. This spot then occupies a position on the screen of the tube corresponding to the phase of the modulating frequency at the transmitter and the position of the receiver with respect to the transmitting antennas. Whenever the momentary cessation of transmission occurs, the spot will no longer be affected by the deflecting plates and it will tend to travel to the outer edge of the screen. It returns to its normal orbit as soon as the radiation again is present. The result is a circle with a *V* notch on its periphery. The position of this notch is the bearing of the receiver with respect to the transmitting station.

Geographical Coverage of Ultra-high-frequency Radio Ranges.

The limited range of ultra-high-frequency transmission along the surface of the earth, because of the observance of optical laws, is well known. On first thought one may be inclined to question the use of these frequencies for supplying guidance to long-range craft.

Factors entering into the propagation of ultra-high frequency waves have already been discussed under Effects of Wave Polarization; however, this simplified formula has been found to give good approximations:

$$E_f = 3.2 \frac{\sqrt{P}}{\lambda} \cdot \frac{h_r h_t}{d^2} \quad (70)$$

In this expression, E_f = field strength, microvolts per meter
 P = transmitter power, watts
 λ = wave length, meters
 h_r = height of receiving antenna, feet
 h_t = height of transmitting antenna, feet
 d = distance between receiver and transmitter, miles

In the preceding equation it is assumed that the transmitting antenna is a half-wave dipole located an appreciable distance above the earth and that the value of d is great as compared with either h_r or h_t . The limit of the optical path for spherical earth may be taken as the geometric shadow. This shadow occurs when

$$d = 1.222(\sqrt{h_r} + \sqrt{h_t}) \quad (71)$$

That is, Eq. (70) is true only for distances not greater than those given by Eq. (71). Actually, Eq. (71) does not take into account the refraction, so in the limit an appreciable field strength may be present beyond the distance given by Eq. (71). Compensation may be made by assuming a radius for earth equal to four-thirds of the actual radius. When this is done, Eq. (71) becomes

$$d = 1.4(\sqrt{h_r} + \sqrt{h_t}) \quad (71a)$$

A curve of field strength versus distance for various altitudes is shown in Fig. 55. In computing the curves of this figure a transmitter operating on a frequency of 125 megacycles with a power of 300 watts was assumed to be coupled into a 100 per cent efficient half-wave antenna located 30 ft. above the ground. The limits of the optical paths are also marked on the curves of Fig. 55. These data show that, within the optical path, field strengths of 250 to 350 μv per meter can be expected at altitudes above 1,000 ft. for minimum distances of 50 miles. The distance that can be served by one of these ranges is twice the radius

or at least 100 miles when the altitude is above 1,000 ft. In mountainous country this distance may be decreased to about 70 miles, but a 300-watt transmitter will deliver a very powerful signal within this distance.

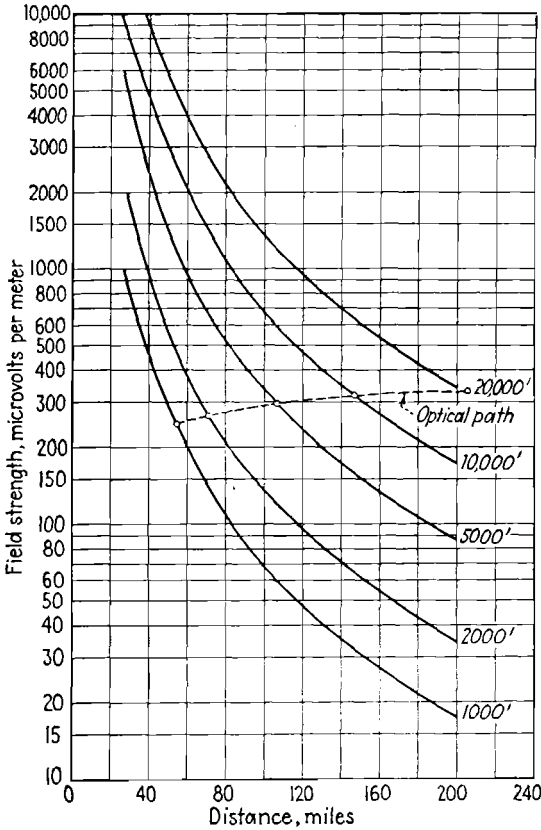

FIG. 55.—Field strength from a 300-watt 125-megacycle transmitter. The transmitting antenna is 30 ft. above the ground and the receiving antennas are at various heights as indicated by the figures on the curves. The limiting optical path is also indicated assuming a radius of curvature equal to four-thirds that of the earth.

Aircraft Ultra-high-frequency Range Receiver.—To date, the only receivers that have been constructed for use with the ultra-high-frequency radio ranges are some experimental units. There is often a vast difference between experimental models and the units that are found satisfactory for extensive use in transport

service. A number of receivers are being manufactured, however, and the characteristics of these will now be discussed.

It is desirable that such a receiver be useful for more than one service, because then a single space unit will serve as a safety factor for a number of receivers. The frequency assignments that have been made for various aviation services range from 75 to 142 megacycles. Not all the frequencies in this band are available for aviation use, but nevertheless the number that is available is large. It is probably impractical to attempt the design of a single receiver that covers all these frequencies; however, a number of these frequencies (intended for various uses) are to be incorporated in two of the receivers that are under construction. One of these receivers covers the frequency range from 109 to 110.5 and 119 to 132 megacycles. The first portion of the band is for landing-system localizer reception, and the second portion is for reception of radio-range and traffic-control signals. In order to facilitate tuning, the receiver is arranged for fixed-spot tuning on 30 frequencies. It is only necessary to operate a rotary switch to one of 30 positions in order to obtain the desired frequency. The mechanism for this purpose consists of a mechanical arrangement that rotates the shaft of a tuning condenser. For certain frequencies, a relay operates simultaneously with the rotation of the condensers and serves to change certain inductors.

This receiver is not crystal controlled, but the oscillator has been designed to have the equivalent stability. Naturally this required careful oscillator design using special inductors, temperature-compensated condensers, etc. The specification contemplates the use of a coaxial two-wire transmission line connecting to the antenna. In order that the transmission line remain balanced electrically with respect to ground, an electrostatic shield is provided between the primary and secondary of the antenna transformer.

The inductors used are simple solenoids with diameters of about $\frac{1}{4}$ in. A better ratio of reactance to resistance probably could be obtained by using transmission lines as elements in the tuned circuits; however, the large space occupied by the frequency-selecting mechanism limits the available space and, hence, precludes the use of the larger lines. The inductance of the coils is adjusted by the use of a brass screw for the core.

The requirement for the suppression of the image frequency is 60 db. This requirement is not excessive in view of that usually specified for low-frequency receivers, but because of the tracking problem and the difficulty of securing amplification at these frequencies with the tubes available, the use of a first radio-frequency stage presents difficulties, and hence the image-suppression problem becomes more difficult. Suppression of image-frequency response is secured by using a filter consisting of coupled circuits. This filter is shown in Fig. 56.

The selectivity requirement specifies that the attenuation of a signal displaced 60 kc. from the frequency of maximum response shall not be more than 6 db. Further, it is specified that the

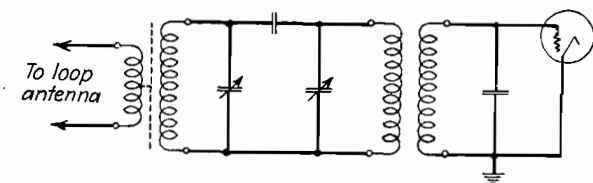

FIG. 56.—Filter circuit used to increase the image frequency rejection in an ultra-high-frequency receiver.

attenuation of a frequency 200 kc. from the frequency of maximum response shall not be less than 60 db. This requirement is met by using three stages of intermediate-frequency amplification. Only two detectors are used. This procedure simplifies construction, and there is apparently no need for further reducing the intermediate frequency. An intermediate frequency of 13 megacycles was chosen.

The sensitivity is specified so that a $5\text{-}\mu\text{v}$ signal modulated 30 per cent will produce an output of 30 mw. with a signal-to-noise ratio of 6 db. Two audio systems are required—one for aural use and the other for operating a right-left meter. The audio circuits leading to the meter-rectifier system are required to transmit 90 and 150 cycles equally within $\frac{1}{4}$ db. The audio circuit is required to have substantially linear response from 500 to 2,500 cycles.

Because there is a constant carrier present at all times with the 90 and 150 cycles transmitted as side bands, it is possible to use automatic gain control without modifying the width of the range path. An automatic gain control assuring constant

output (within 1 db) for input voltages varying between 50 and 100,000 μ v is provided.

A single "acorn" type tube is used as a harmonic generator, but the other tubes are of the standard type. The first detector position is occupied by a high amplification-constant tube (type 1852 or 6AC7).

The weight of the receiver, together with its frequency-changing mechanism, is 35 lb.

Ultra-high-frequency Range-receiving Antenna.—The fact that an Alford loop can be used for receiving was previously mentioned, but there are a number of factors that must be considered when it is desired to use this antenna on airplanes. The first of these is the horizontal field pattern of the loop antenna. This pattern has been previously said to be essentially circular for a loop used as a transmitting antenna. It would also be circular when used as a receiving antenna if it were mounted above a uniform metallic plane of good conducting material. Unfortunately the structure of an airplane is not such that it answers this description. For structural reasons, as well as electrical reasons (short leads), it is necessary to mount this antenna above or below the fuselage. The contours of this aerodynamic structure are such that it rapidly falls away from a center point; hence the reflections from all points beneath the antenna are not the same and serve to distort the circular pattern.

The desirability of a circular pattern for instrument landing will be discussed in greater detail in Chap. VI. For visual-range reception utilizing automatic gain control, there can be appreciable distortion in the antenna pattern without detrimental effects. Only if separated lobes are present, which by chance bring areas of null reception to bear on the true signal and areas of maximum reception to bear on spurious radiation, would visual range flying be hampered by antenna-pattern irregularities. For the aural range, where change in signal intensity is important, severe receiving antenna pattern irregularities would hamper flying. There is a "shadow" caused by the tail of the airplane; that is, the tail prevents or decreases reception in a direction to the rear of the airplane. The closer the antenna is mounted to the tail, the more pronounced will be the shadow effect. On the other hand, there is a discontinuity at the windshield

of the airplane, and the metal forward of this point is much lower than that to the rear of it. The best antenna location is therefore determined by the structure of the airplane, and no theoretical solution of this problem has yet been worked out, although such a solution could conceivably be developed. Determination of the optimum location is made by mounting the loop in the desired position and turning the airplane while it is on the ground.

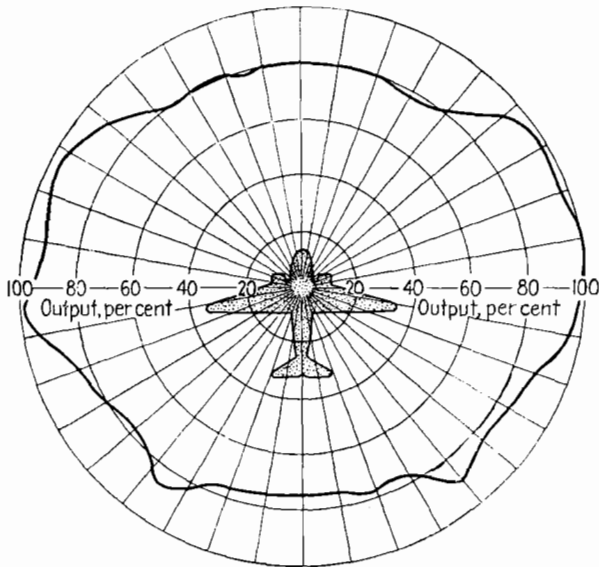

Fig. 57.—Field pattern of an Alford receiving loop mounted on a Douglas Model DC-3 airplane.

A position for the airplane is selected approximately 200 ft. from a transmitter, and the receiver output is recorded as a function of the airplane heading as read from the directional gyro. Figure 57 shows a field pattern obtained in this manner. It is usually necessary to calibrate the receiver by plotting input versus output; otherwise, a square-law detector might accentuate pattern irregularities. In Fig. 57 the effect of the tail can still be noticed, but it is not pronounced. It is not necessary that the pattern be absolutely circular although it should be within plus or minus 2 db.

Some correction for pattern irregularity can be made by changing the dimensions of the loop and also its current distribu-

tion. The current distribution, as previously discussed, can be changed by varying the capacity at that extremity of the antenna to which the transmission line is not connected. As the dimensions of the loop are made smaller, its efficiency becomes lower but the pattern becomes more regular. If a loop is to be operated on a single frequency, it may have a diameter of not more than 12 in., but a larger loop is desirable if it is to be used over a large band of frequencies in order that its efficiency will be equal over the entire band; hence it must have an inherently larger efficiency in order that the loss at some of the frequencies can be tolerated. The efficiency is a function of the area, so the loop may be designed to have an aerodynamic contour more suitable than a circle.

The pattern shown on Fig. 57 is for a loop intended to operate at 93 and 109 megacycles (two frequencies only). It was constructed of $\frac{1}{2}$ in. diameter duralumin tubing and was in the form of a circle having a $15\frac{1}{2}$ in. diameter. It was mounted on a Douglas DC-3 airplane 18 in. above the fuselage. Because of the high dielectric constant of water, rain detunes this antenna; so for practical-flight use it is necessary to encase the antenna conductors or the entire antenna in a plastic form. This form should be so constructed that not less than $\frac{1}{2}$ -in. air space is present between the plastic material and the antenna conductor.

Another problem that must be solved in using an Alford loop as a receiving antenna is its tuning over a range of frequencies. Means for tuning this antenna for a single frequency have already been suggested; however, the problem of operating over a band such as 93 to 132 megacycles requires some special engineering. Of course it would be possible to locate a tuning unit at the base of this antenna (or, still better, directly at the antenna) and so arrange this unit with suitable motor drive, cams, etc., that the antenna tuning would vary and be correct for any frequency. This would be difficult to accomplish, however, if there is to be more than one receiver on the same antenna, each operating on a different frequency.

The present plans for commercial airplanes call for the use of four receivers on a single loop antenna.

It is not possible to use the antenna without tuning it because its sensitivity would be too low. The transmission line associated with the antenna would be a suppresser for most of the fre-

quencies, and insufficient signal would be delivered to the receiver.

A solution to this problem consists in using several sections of line coupled to the main transmission line. Such an arrangement is shown in Fig. 58.

The transmission line connected to the loop of Fig. 58 is adjusted so that it is in tune for a frequency of 119 megacycles.

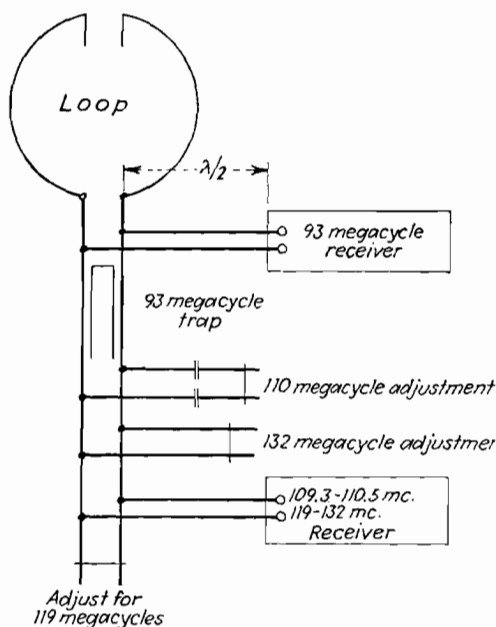

FIG. 58.—Transmission-line network arrangement used to tune loop antenna at various frequencies and permit the attachment of more than one receiver.

At the maximum-current point near this short circuit there is attached the 119- to 132-megacycle receiver. Next, a point is found, as close to the antenna as possible, where maximum current exists for a frequency of 93 megacycles. A half-wave transmission line is used to connect the 93-megacycle receiver (or receivers) to this point. The half-wave line is a convenience that allows a long lead to the receiver. Any integral multiple of a half-wave line may be used. When the receiver is attached, it will be found that the pickup on the 119- to 132-megacycle receiver will be reduced considerably (at 119 megacycles); so

a 93-megacycle trap(12) is introduced just below the point where the transmission line for the 93-megacycle receiver is attached. This trap is a one-fourth wave-length section of line coupled to the main transmission line and tuned to 93 megacycles. With the installation of this trap, the signal strength from the antenna at 119 megacycles will return to nearly its former value. Further compensation for the frequencies at the extremities of the band must be made. It is necessary to compensate for the extreme frequency of 132 megacycles by introduc-

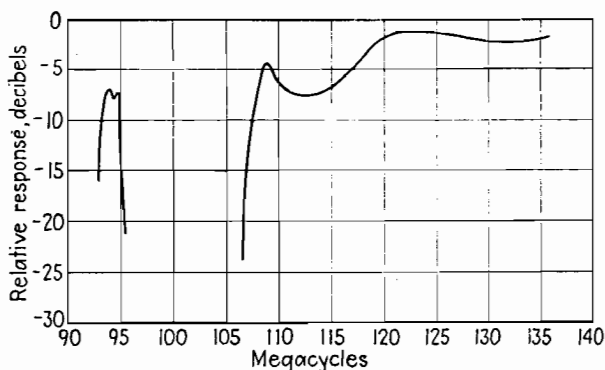

FIG. 59.—Reception characteristic of a modified form of the Alford loop and network.

ing an additional section of line adjusted for this frequency. It is also necessary to add an additional section to compensate for the antenna tuning at 110 megacycles. This is accomplished by a modified form of the coupled line. In this case the short section is coupled to the main line with small condensers. This section of line serves to boost the 110-megacycle signal without detracting appreciably from the adjustments made for the other frequencies.

The antenna network described above was given as an example of various methods of securing tuning of the loop over a range of frequencies. It is possible to use additional elements of the character described in order to accomplish tuning for various other problems. The theory of all these sections follows from transmission-line reflection considerations because this line is one on which standing waves are present.

The satisfactory characteristics of an Alford loop and network somewhat similar to those discussed are shown in Fig. 59.

Problems

1. Using the method described in "Graphical Determination of Polar Pattern of Directional Antenna Systems," by G. L. Davies and W. H. Orton in *Bureau of Standards Research Paper 435* or *Bureau of Standards Journal of Research*, Volume 8, May, 1932, develop the pattern for the antenna system shown on Fig. 52. Show all construction and calculation.

2. What field strength will be produced by a half-wave transmitting antenna located 35 ft. above the ground and connected to a 5-watt output transmitter at a point in space 50 miles distant from the transmitter and at an elevation of 3,000 ft. aboveground? Also solve this problem substituting a 1-kw. for the 5-watt transmitter. Prepare a discussion of the transmitter power that you would recommend.

3. What is the difference between the maximum optical distances when the diameter of the earth is taken as actual and as four-thirds actual for antenna heights of 35 and 1,500 ft.?

Bibliography

1. KEEN, R.: "Wireless Direction Finding," 3d ed., p. 185, Iliffe & Sons Ltd., London, 1938.
2. ESHBACH, OVID W.: "Handbook of Engineering Fundamentals," Chap. 9, p. 04, John Wiley & Sons, Inc., New York, 1936.
3. PEDERSON, P. O.: "Propagation of Radio Waves," p. 117, G.E.C. Gad, Copenhagen, 1927.
4. JACKSON, W. E.: The Impetus Which Aviation Has Given to the Application of Ultra-high Frequencies, *Proc. I.R.E.*, February, 1940, p. 49.
5. BURROWS, C. R.: "Radio Propagation over Plane Earth," *Bell System Tech. Jour.*, Vol. 16, pp. 45-75, January, 1937.
6. JACKSON, C. H., and J. M. LEE: Preliminary Investigation of the Effects of Wave Polarization and Site Determination with the Portable Ultra-high-frequency Radio Range, *CAA Tech. Development Rept. 24*, February, 1940.
7. HROMADA, J. C.: Preliminary Report on a Four-course Ultra-high Frequency Radio Range, *CAA Tech. Development Rept. 3*, January, 1938.
8. ALFORD, ANDREW, and A. G. KANDOIAN: *A.I.E.E., Tech. Paper 40-45*, January, 1940.
9. LUCK, DAVID, G. C.: An Omnidirectional Radio Range System, *RCA Rev.*, Vol. 6, No. 1, p. 55, July, 1941.
10. HUND, AUGUST: "High-frequency Measurements," p. 72, McGraw-Hill Book Company, Inc., New York, 1933.
11. BURROWS, C. R., A. DECINO, and L. E. HUNT: Ultra-short-wave Propagation over Land, *Proc. I.R.E.*, December, 1935, p. 1507.
12. ALFORD, ANDREW: Transmission Modifying Network, U.S. Patent No. 2,159,648, May 23, 1939.

CHAPTER IV

AIRCRAFT DIRECTION FINDERS

The previous chapter was introduced by the discussion of an aberration attending low-frequency range operation. The reason for introducing the chapter in this manner was that the ultra-high-frequency range was developed chiefly because of the unsatisfactory properties of the low-frequency range. Although aircraft direction finders brought a facility to aviation that is now considered indispensable, they too were introduced aboard transport aircraft as a cure for an undesirable phenomenon associated with low-frequency range operation. It is in order, then, to introduce this chapter with the discussion of a phenomenon that, historically at least, is related to aircraft direction finders.

Precipitation Static.—This phenomenon was not first discovered with aircraft flight but had been experienced at radio receivers located on the ground(1); however, it never occurs with such frequency and intensity on the ground as in flight. As an airplane flies through areas of precipitation consisting of rain, snow, ice crystals, or dust, a series of "popping" sounds are heard in the long-wave radio receivers. As flight continues, the sound begins to resemble the noise of frying grease. Later this sound becomes quite musical, then it reaches the proportions of a roar. At this time, all semblance of reception ceases. Several factors or conditions were noticed to have a bearing on this phenomenon. Although experienced with the slower speed airplanes, this unusual condition did not really become an ever-present menace to radio-range reception until the higher speed airplanes were placed in operation by the airlines beginning in about 1932. It was usually possible to decrease the intensity of this disturbance by decreasing the speed of the airplane.

Aeronautical radio engineers and physicists developed various theories regarding the cause of this disturbance to radio reception. The more popular theory was consistent with the conclusion

drawn by engineers who observed the ground-station static. This theory held that the noise was caused by charged particles striking the antenna(2). Accordingly, in 1935 both United Air Lines and Transcontinental & Western Air constructed shielded loop antennas for use under conditions of precipitation. It was found that in moderate conditions of precipitation static, this loop decreased the noise by as much as 30 db. It was also found, however, that range courses suffered apparent distortion with the loop, particularly when the airplane was near the radio station. This effect will be discussed in detail later. In order to compensate for this distortion, it was decided to make the loop rotatable and use bearings taken with it as a further aid to avigation. With these bearings taken from two stations suitably located with respect to the airplane, its position could be determined. If the airplane was already on a known leg (or course) of the radio range, a single bearing served to give the pilot a "fix." The Bureau of Air Commerce in 1937 issued an order making direction finders using shielded loop antennas mandatory. The subject of direction finders will be discussed further, but before continuing, the results of further research into precipitation static will be related.

Cause of Precipitation Static.—Several factors noticed during the time the precipitation static was present did not agree with the "particles striking the antenna" theory. These factors did not serve to negate the theory, but they brought about further research. It was found that St. Elmo's fire (corona) was often present on the windshield and propeller tips of the airplane during these static conditions. If the airplane's radio transmitter was used, or a stroke of lightning occurred near by, the static often ceased momentarily. Also, although the static received on the loop antenna had a ratio of 30 db compared with that received on a standard antenna for weak precipitation static, this ratio was often less than 1 db under conditions of heavy precipitation static. Although a loop antenna was used, certain static conditions were so severe that a range signal could not be heard when in the immediate vicinity of the radio station.

In November, 1936, United Air Lines assembled a group of scientists and equipped an airplane as a flying laboratory in an attempt to determine the true cause of precipitation static and, if possible, a means for its further reduction(3). It was found

that the major cause of this static was not the charged particles striking the antenna, but the airplane accumulating a charge which eventually discharged in the form of corona, thereby creating a disturbing electrical field. Dr. R. H. George, a member of this expedition, suggested as a means for discharging in a noise-free manner this accumulated charge a fine wire trailing from the rear of the airplane. The diameter of this wire is smaller than any other point on the airplane. In series with it is a high-value resistor. This wire, being finer than any other point on the airplane, first develops corona, but the resistor in series with it has a resistance of perhaps 100,000 ohms, and hence renders the discharge aperiodic, thereby causing the charge to be lost without a noise attending its departure. More efficient dischargers can of course be constructed, and some forms of these will be discussed later. It can be seen that the addition of voltage on the antenna of the airplane by the transmitter actually caused this discharge; also, the lightning discharged the local area and caused the airplane to lose its charge. All these observations are consistent with the newer theory.

The reason an electrostatically shielded loop antenna served to reduce the noise is explained by Starr(4). The currents resulting from this corona discharge are shown to be composed of steady components with superimposed double-exponential impulses. These currents can be represented by a series of multiple-frequency waves. These waves will produce true electromagnetic radiations, but since the value of current in corona is very small and because the radiation field is a function of the effective height of the radiator and the current flowing in it, this true radiation will be comparatively weak. The induction field, however, is very intense because it is largely a function of voltage. The charge on the airplane during its flight in precipitation areas reaches several thousand volts. Since the induction field does not propagate (strictly speaking), its effect is noticed only in the immediate vicinity of the discharge; however, the antennas are located near the source of the disturbance, so they are appreciably affected. The shielded loop covered with a metallic sheath which is connected to ground prevents the electric induction interference from reaching the wires of the loop, and only the magnetic field is accepted. If the quantity of electric charge on the airplane is small and the

discharge is also small, the magnetic field will be below the level of receiver sensitivity, and since the loop will entirely eliminate the electric field, its use will remove the static disturbance. If now the charge on the airplane and the rate of discharge are great, and create a powerful magnetic field, the loop antenna will *not* serve to eliminate the interference.

This last effect is also true if the loop is located too close to the source of the discharge and the magnetic field reaching the

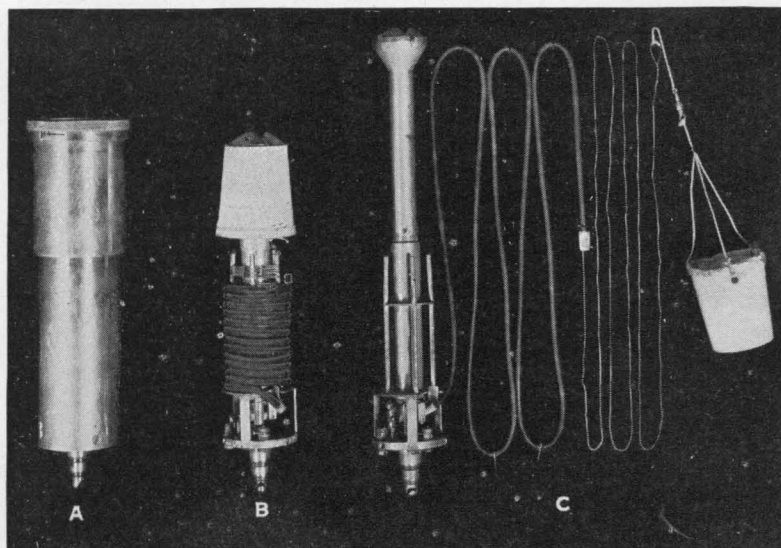

FIG. 60.—Precipitation static discharge cartridges: (A) fully assembled, (B) loaded but with outer casing removed, and (C) disassembled and discharged. (Courtesy of United Air Lines.)

loop antenna is of an intensity sufficiently high that the antenna will respond to it. It has been found that in the usual case more disturbance is caused in the 200- to 400-kc. frequency than in the 3- to 6-megacycle band. It has also been found that, as the discharge intensity is decreased by the release of the static discharge wire and suppressor, reception on the high-frequency range is often cleared completely; whereas less benefit (apparent at least) accrues on the low-frequency range. The use of the shielded loop to eliminate electric induction-field antenna response, together with the discharger wire to reduce the intensity of the corona, generally results in readable range signals.

Although the static discharging wire is often attached to the rear of the airplane and allowed to trail behind permanently, one of the forms of this device stores the wire until actually needed. This form is shown in Fig. 60. The device shown in this figure consists of a cylindrical housing that plugs into a socket in the tail of the airplane. In this housing is a spring-loaded plunger that normally is held compressed by means of an

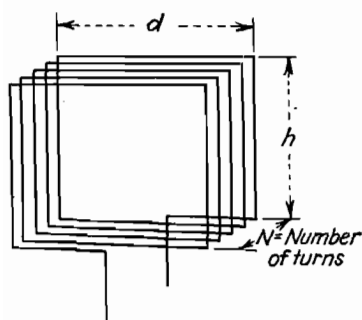

FIG. 61.—Diagram of a long-wave loop antenna.

electrically actuated trigger. When the trigger is released by applying voltage to the contacts at the rear of the housing, the plunger breaks a sealing parchment-paper cap and releases a small wind cone. The wind cone is caught by the slip stream of the airplane and unreels the discharging wire and suppressor. No attempt is made to return the wire to the housing while the airplane is in flight. Servicemen replace

the discharged units with new units when the airplane lands and rewind the wire in the service shops.

The Loop Receiving Antenna.—The loop has previously been discussed as a transmitting antenna, and it will now be discussed as a receiving antenna. By referring to Fig. 61, it can be seen that the receiving loop antenna is a winding that can be composed of any number of turns, N , of wire. The radio wave is composed of a magnetic and electric field. If the electric field is neglected for the moment, it can be seen that the loop is no different from the secondary of a transformer subjected to a magnetic flux of varying intensity. The instantaneous induced voltage may be written by Faraday's law as

$$e = \frac{N d\phi}{dt} \quad (72)$$

where e = abvolts

N = number of turns

ϕ = magnetic flux, maxwells

t = time, seconds

Equation (72) can also be written as

$$E_L = \omega\phi 10^{-8} \quad (73)$$

where $E_L =$ volts

$$\omega = 2\pi f$$

$f =$ cycles per second

If the flux density is B , then

$$\phi = B(\text{area of loop}) = Bhd \quad (74)$$

In this expression, h and d are the dimensions of the loop as shown in Fig. 61.

If H is the magnetomotive force, B equals H when the permeability of the coupling material is one (as it is for air); therefore

$$E_L = \omega NIA10^{-8} \quad (75)$$

In this expression, d and h , the dimensions of the loop, have been replaced by A , the area (in square centimeters).

The dimensions of the loop must be small in order for the preceding expression to hold true; otherwise, the flux would not

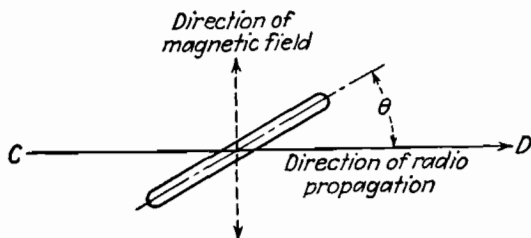

FIG. 62.—Relation of angle between plane of loop antenna and direction of wave propagation.

be uniform throughout the area, and standing waves would be present on the loop winding.

Referring to Fig. 62, the arrow CD represents the direction of propagation of the radio wave, making an angle θ with the plane of the loop antenna. The magnetic field in a normally polarized wave is at right angles to this direction of propagation.

If the wave is traveling parallel to the plane of the loop, it will cut first one side, then the other, and produce the greatest phase difference in the voltages induced. If, however, the plane of the loop is at right angles to the direction of wave travel, the magnetic field will cut both sides of the loop simultaneously. Hence, H , the magnetic field for an angle θ between the plane

of the loop and the direction of propagation of the radio wave, will be

$$H = H_{\max} \cos \theta \quad (76)$$

In this expression, H_{\max} does not signify the peak value of H , but its maximum effective value. Placing Eq. (76) in Eq. (75), the following equation results:

$$E_L = \omega H_{\max} N A \cdot 10^{-8} \cos \theta \quad (77)$$

If Eq. (77) is plotted as a function of the angle θ , the resulting curve will be the familiar figure-8 pattern of the transmitting loop. That is, as a loop receiving antenna is rotated about a vertical axis there will be two positions for which the output is zero and two for which it is maximum.

Equation (77) was developed by treating the loop as the secondary of a transformer, and no account was taken of the presence of an electric field. The electric field will also induce voltages in the sides of the loop. Since the sides of the loop are short compared with a wave length, the voltage induced per unit of length will be small but, nevertheless, will have an appreciable value. These induced voltages have values with respect to each end of a vertical loop side as well as with respect to ground. If the vertical sides of the loop are connected at their tops by means of a horizontal conductor (in which no voltage is induced), then between the bottoms of the vertical sides there will be a voltage difference. The mathematical laws governing the value of this voltage (but not the voltage between the loop and ground) will now be developed, the assumption being that only an electric field is present.

If the electric field in volts per unit of length is ϵ , the voltage induced in one vertical wire of the loop of Fig. 61 will be

$$E = \epsilon h \quad (78)$$

For N number of such wire lengths,

$$E = \epsilon h N \quad (79)$$

but a similar voltage is also induced in the turns on the opposite side of the loop, so the potential difference would be zero if the phase of the voltages were equal. The relative phase of the induced voltages is a function of the added distance that the

electric field must travel in reaching the second side as compared with the distance that it travels in reaching the first side. This phenomenon is shown in Fig. 63. The point P is the origin of the radio wave. The angle between a line drawn from one side of the loop to the source of the radio wave and the plane of the loop is θ_1 , and the angle between the plane of the loop and the line between the second side and the same source of the radio wave is θ_2 . If the distance between the loop and the source of

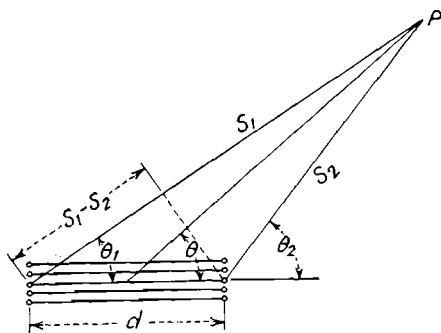

FIG. 63.—Energy received from point P induces voltages in the sides of the loop, but since the distances S_1 and S_2 are not equal, the phase of the induced voltages is not the same, so a resultant voltage remains.

the radio wave is great compared with the distance between the sides of the loop, then the difference between the distances from the source of the radio wave to the sides of the loop will be (see Fig. 63)

$$S_1 - S_2 = d \cos \theta_1 \quad (80)$$

Also, θ_1 will nearly equal θ , so

$$S_1 - S_2 = d \cos \theta \quad (81)$$

The phase difference ψ between the voltages induced in the two sides is the difference distance expressed as a portion of a wave length. This wave length may in turn be converted to radians

$$\psi = \frac{2\pi d}{\lambda} \cos \theta \quad (82)$$

The resulting loop voltage E_L will be the vectorial difference between the voltage in the two sides of the loop, and from Fig. 64 and trigonometry,

$$\begin{aligned}
 E_L &= \frac{E \sin \psi}{\sin (90^\circ - \psi/2)} \\
 &= \frac{E \sin \psi}{\cos \psi/2} \\
 &= \frac{2E(\sin \psi/2 \cos \psi/2)}{\cos \psi/2} \\
 E_L &= 2E \sin \frac{\psi}{2} \tag{83}
 \end{aligned}$$

Then substituting Eq. (82) in Eq. (83), the following equation results:

$$E_L = 2E \sin \left(\frac{\pi d}{\lambda} \cos \theta \right) \tag{84}$$

In practice, d is usually very small as compared with λ . For airplane installations, d seldom exceeds 1 ft. although λ is often

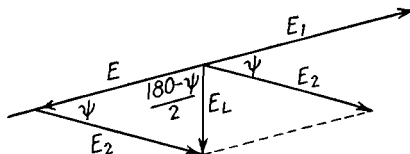

FIG. 64.—Voltage resulting from the vectorial addition of the voltages induced in the sides of the loop.

9,000 ft. or more. This means that the angle $\frac{\pi d}{\lambda} \cos \theta$ will be very small. Since for small angles the sine is equal to the angle, Eq. (84) may be written without appreciable error in this form

$$E_L = \frac{2E\pi d}{\lambda} \cos \theta \tag{85}$$

Substituting Eq. (79) in Eq. (85),

$$E_L = \frac{2\pi}{\lambda} dhN\epsilon \cos \theta \tag{86}$$

Since dh is the area A of the loop, then

$$E_L = \frac{2\pi}{\lambda} AN\epsilon \cos \theta \tag{87}$$

but

$$H = c\epsilon \tag{88}$$

and

$$\frac{c}{\lambda} = f \quad (89)$$

where c is the velocity of propagation of the radio waves. Further,

$$\omega = 2\pi f$$

therefore

$$E_L = \omega H_{\max} NA \cdot 10^{-8} \cos \theta \quad (77)$$

This is identically the same expression as was previously developed. In practice, the field strength is usually expressed as volts. In practical form Eq. (77) becomes

$$E_L = \frac{2\pi}{3} f E_{\max} NA \cdot 10^{-10} \cos \theta \quad (90)$$

where ϵ is in volts per centimeter, A in square centimeters, f in cycles per second, and E_L in volts.

It can be seen that whether the induced voltage is considered a phenomenon caused by the electric or the magnetic field, the results are the same. Further, as far as the voltage measured between the bottom ends of the loop's vertical turns is concerned, when the top ends are connected, it will have the same value if *only* the magnetic or *only* the electric field is considered. This discussion was directed only to an unshielded loop.

Phase of the Induced Voltage.—There is an important difference existing between the voltage induced in a loop antenna and that induced in an open antenna. The voltage delivered at the terminals of a loop antenna represents the difference between two induced voltages, whereas the voltage at the terminals of an open antenna is merely the induced voltage. The other terminal, or point of potential of the open antenna, is the ground. It follows, then, that the maximum instantaneous voltage at the terminals of a loop occurs when the difference between the voltages induced in the two sides of the loop is the greatest. This greatest difference will exist when the inducing wave has zero potential at the center of the loop. At this time the voltage induced in one side will be negative and in the other side positive. The instantaneous voltage in an open antenna will, however, be maximum whenever the inducing wave is maximum. By referring to Fig. 65, it can be seen that the voltage induced in a

loop will be 90 deg. out of phase with the voltage induced in a near-by open antenna.

Unbalanced Current Effects.—If a loop antenna having one turn is cut at the center of the turn, and each end of the normal loop is connected to ground, currents induced in the individual sides will flow to ground, because the electrostatic field induces in each side a voltage having a given value with respect to ground.

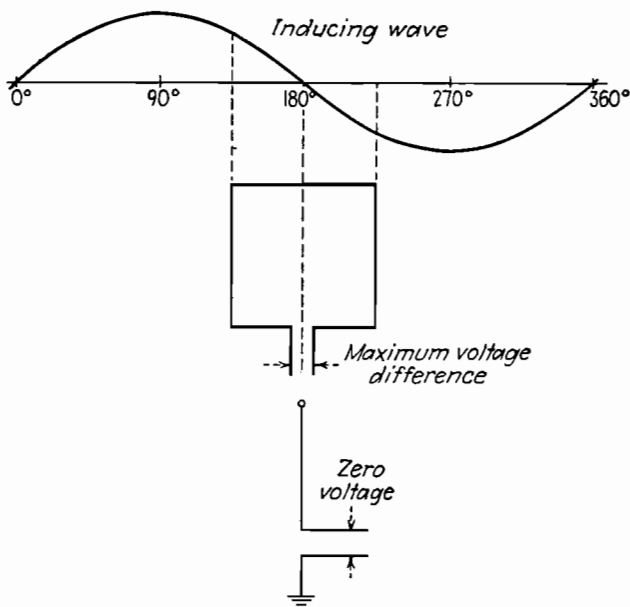

FIG. 65.—A radio wave induces a maximum voltage difference when it is passing through zero at the center of the loop, but at this time it induces zero voltage between a vertical antenna and ground.

The rotation of the loop antenna in this case would have no bearing on the value of the currents that would flow. This is shown in Fig. 66. If now the loop turn is again completed and its free ends are connected, a current will flow in the loop that will be a function of the differences between the voltages induced in the loop sides. This is shown in Fig. 67. If now the ends of the loop are connected to each other and also to ground, two currents will flow. One of these will have no varying value with respect to direction, whereas the other will vary with the position of the plane of the loop. The presence of the current having no

variation with respect to loop position eliminates the null, and the pattern may be an ellipse rather than the two tangential circles

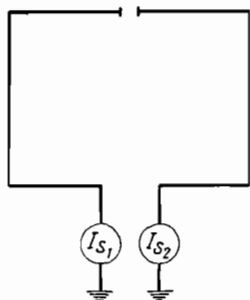

FIG. 66.

FIG. 66.—Currents flowing from each side of a loop to ground because the loop turn is broken and the sides are grounded.

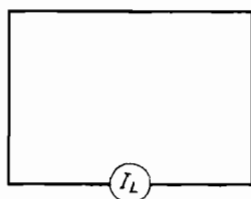

FIG. 67.

FIG. 67.—Loop current only flowing because loop turn is complete and does not connect to ground.

of the figure 8. In order to maintain the figure-8 pattern, then, it is necessary that no current flow from the loop antenna to

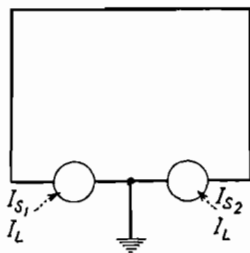

FIG. 68.

FIG. 68.—Both ground and loop currents flowing because loop turn is complete and loop is grounded.

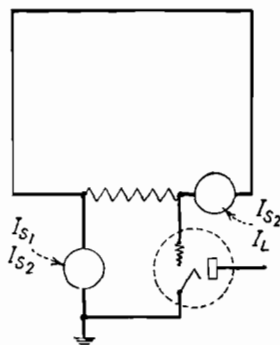

FIG. 69.

FIG. 69.—Current flowing from one side of loop to ground develops a voltage across the input impedance of a receiving device. This voltage adds to that developed by the loop current flowing through the input impedance, thereby causing a distortion of the figure-8 field pattern.

ground, or if such current flows it shall not produce a voltage in the direction-finding receiver.

In Fig. 69 is shown a loop connected to an impedance. Across this impedance is connected a vacuum tube actuated by a

voltage which is a function of the current flowing through the impedance. If I_{s1} is the current flowing to ground from one side of the loop, I_{s2} the current flowing to ground from the other side of the loop, and I_L the loop current, it can be seen that the voltage impressed at the grid of the tube will be a function of both I_{s2} and I_L ; therefore, the field pattern of the loop will not

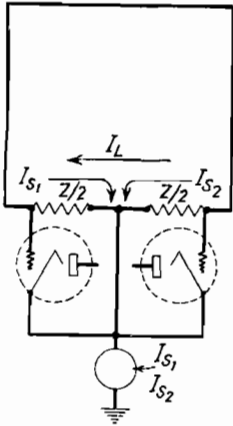

FIG. 70.—System for balancing out the effects of currents flowing from sides of loop to ground and retaining only the effect of the loop current.

be a true figure 8. In Fig. 70 is shown another loop connection. Here two vacuum tubes are used. Currents from each side of the loop flow to ground via one half of the coupling impedance. The potential difference between the grids of the two tubes due to these earth currents is zero since each current sets up a voltage across each half of the impedance, which is exactly equal and opposite to the voltage set up in the other half of the coupling impedance by the earth current from the other side of the loop. The only potential difference between the two grids will be caused by the currents flowing from one side of the loop to the other. This potential difference is truly a function of the position of the plane of the loop and therefore follows a figure 8 with well-defined maximum and minimum positions.

Shielded-loop Antennas.—There are a number of circuits that may be employed which make possible the utilization of the loop voltage without causing the figure-8 field-strength pattern to distort. Many of these, however, limit the receiver-input circuit so that it is not possible to obtain arrangements suitable for radio-compass work. The simplest solution to this problem consists in using a shielded loop. In addition to solving the electrical problem, the shielded loop also has an ideal mechanical construction that is capable of successfully withstanding aircraft service. The majority of the aircraft loop antennas constructed in the United States during recent years have used this construction.

A shielded-loop antenna is one that has a metallic cover over the winding of the loop. This cover has a break at one point and is connected to ground.

Figure 71 is a diagram of a shielded-loop antenna. The circulating currents induced in the shield are assumed to be negligible in this discussion. Since this shield does not constitute a closed turn, the magnetic field will produce a voltage across its open ends, but no current can flow. The magnetic field will penetrate the shield; therefore it will act on the conductors within and hence induce a voltage given by Eq. (77).

This voltage will cause the current I_L to flow through impedance z of Fig. 71. The electric field will induce a voltage in the vertical sides of the shield. This voltage will have a value with respect to ground and will cause currents I_{s1} and I_{s2} to flow from each side of the shield to ground. These currents in turn will induce voltages in the winding of the loop, and currents will flow in a direction opposite to that of the shield currents.

Currents so induced will be two in number and nearly equal but will have opposing directions of flow. For this reason they will not produce a voltage across the coupling impedance Z . This coupling impedance may have one terminal grounded, but the voltage that produces I'_{s1} and I'_{s2} is a voltage acting within the loop winding and not with respect to ground. Grounding one side of the loop winding, therefore, will not cause earth currents to flow; hence the figure-8 pattern will continue to prevail.

Voltage Output of Loop Antennas.—The effective height of a loop antenna as a receiving device can be easily calculated; hence it is often used as a standard for the measurement of the field strength of signals. Although the effective height of large loop antennas has previously been discussed, it has not heretofore been developed for the receiving loop.

Equation (86) gave for the voltage induced in a loop antenna

$$E_L = \frac{2\pi}{\lambda} dhN\epsilon \cos \theta \quad (86)$$

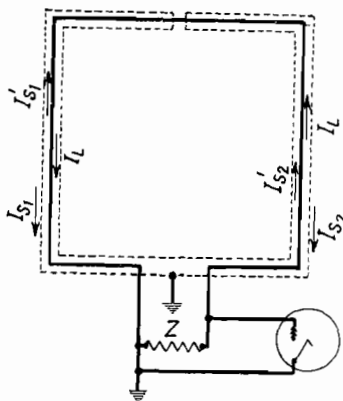

FIG. 71.—Shielded loop antenna. Shield currents flow to ground and the currents which they induce cancel, leaving the total loop current unaffected.

The effective height of any antenna may be defined as a characteristic peculiar to that structure, which characteristic is acted upon by the field of the radio waves to induce a voltage in the structure. Mathematically, then, the effective height of a loop antenna is expressed by

$$h_e = \frac{E_L}{\epsilon} \tag{91}$$

In this equation, E_L is expressed in volts if ϵ is in volts per meter and h_e is in meters.

In Eq. (86) the maximum value of the induced voltage occurs when $\cos \theta$ equals one. For this maximum induced voltage the following formula results when Eq. (91) is substituted in Eq. (86):

$$h_e = \frac{2\pi}{\lambda} AN \tag{92}$$

In this expression, λ is in meters, A in square centimeters, and h_e in meters.

The voltage obtained by multiplying the effective height by the field strength is assumed to be the voltage delivered by a zero-impedance generator acting in series with the impedance of the loop winding.

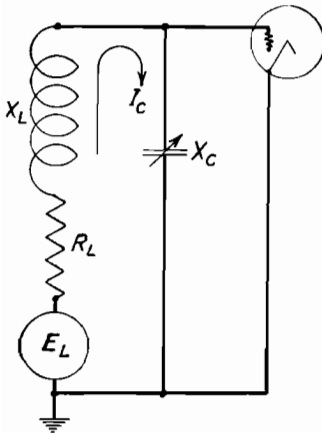

FIG. 72.—Schematic representation of equivalent circuit of a high-impedance loop antenna delivering voltage to the grid of the receiving equipment.

In order that this voltage may be impressed at the grid of the receiving tube, it is common practice to resonate the loop winding with a condenser as shown in Fig. 72. That is

$$-\bar{X}_c = \bar{X}_L \tag{93}$$

The current that will flow through the condenser in this case is limited only by the resistance of the loop antenna (the resistance of the condenser is assumed to be negligible); hence

$$I_c = \frac{E_L}{R} \tag{94}$$

The figure of merit of a coil is usually designated as Q and defined as follows:

$$Q = \frac{X_L}{R} \quad (95)$$

Substituting Eq. (95) in Eq. (94),

$$I_c = \frac{E_L Q}{X_L} \quad (96)$$

The voltage across the condenser is

$$E_R = I_c X_C \quad (97)$$

Therefore, substituting Eq. (96) in Eq. (97) and taking into account Eq. (93)

$$E_R = E_L Q \quad (98)$$

This equation indicates that for a loop that is tuned by a condenser across its terminals the voltage delivered to the receiver is not alone the voltage induced in the loop but is actually the induced voltage multiplied by the Q of the loop.

Of course, it is possible to obtain any value of receiver sensitivity desired in these days of highly developed tubes, but the higher the sensitivity required, the higher is the inherent receiving-apparatus noise. The atmospheric noise voltage induced in a loop antenna is not directly a function of its effective height and Q ; therefore, the higher the Q of the loop, the greater will be the signal voltage delivered to the grid of the first receiving tube, and the greater will be the ratio of signal to noise at the output of the radio receiver. The width of the loop null (for a well-constructed loop) is a function only of the noise present. This is because as the null of the loop is approached the amount of signal rapidly decreases. Its absence occurs when it is masked by noise. If no noise is present, theoretical considerations state that at only one angle will there be a null. The accuracy of the bearing, then, is directly a function of the ratio of reactance to resistance of the loop. This statement is true only of the tuned loop depicted in Fig. 72. This so-called high-impedance loop has certain disadvantages. One of these is that its performance is a function of the moisture of the winding. A high Q is easily destroyed by moisture, and hence the output of the loop is easily decreased. Another disadvantage occurs in aircraft installations where it is usually necessary to locate the loop antenna at some distance from the radio receiver. If a connect-

ing cable is used between the loop and its receiver, a capacity will be introduced across the terminals of the loop. This necessitates a large tuning condenser at the receiver and the loop inductance must be decreased, which automatically decreases the effective height of the loop and hence its induced voltage. A variation of the system of Fig. 72 has been developed and is in common use on aircraft. This system bears the name of the "low-impedance loop."

Low-impedance Loops.—A loop antenna system similar to that of Fig. 73 gives very satisfactory service. It consists of a loop that has only two to eight turns forming a circle with a diameter of 6 to 15 in. Since the inductive reactance of this loop antenna is not high, it is commonly known as a low-impedance loop; this

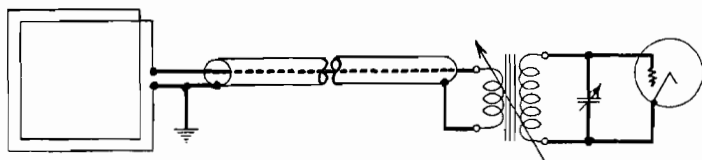

FIG. 73.—Low-impedance loop system.

term also indicates that it is not tuned directly. The low-impedance loop tuning scheme is shown in Fig. 73. As shown in this figure, the loop connects to the receiver by means of a cable having an inner conductor concentric with an outer conductor which may be termed a "shield." Invariably, the insulation used in this cable is of the solid type such as rubber, so it can be seen that no attempt is made to keep the capacity of this cable to a low figure. At the receiver, the cable connects to the primary of a special transformer. The secondary of this transformer is connected to the grid of the first tube and is tuned with a suitable condenser ganged with the other tuning condensers in the radio receiver. The transformer uses a powdered iron core and outer shell in order that the coupling between primary and secondary will be high.

Figure 74 is the electrical equivalent of Fig. 73. In this figure, X_L is the reactance of the loop antenna and R_L is its resistance. The reactance of the self-capacity of the loop antenna and the connecting cable is designated as X_C . The primary of the coupling transformer has a reactance X_1 and a

resistance R_1 , whereas the secondary has a reactance X_2 and a resistance R_2 . The tuning condenser reactance is X_0 , and across it appears the voltage E_0 which is that impressed on the grid of the first tube. The voltage induced in the loop antenna is E_p . The relation of E_0 to E_p does not lend itself to a simple expression; however, by making certain assumptions, a relation indicating the relative importance of the factors involved may be

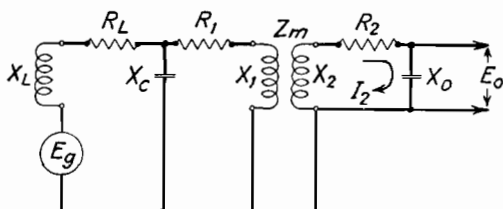

FIG. 74.—Equivalent circuit of low-impedance loop system of Fig. 73.

secured. The secondary current is related to the primary voltage by the expression(5)

$$\frac{E_p}{I_2} = \frac{Z_p Z_s - Z_m^2}{Z_m} \quad (99)$$

where Z_p = total primary impedance

Z_s = total impedance in the secondary

Z_m = mutual impedance

The voltage impressed on the grid of the tube will be

$$E_0 = -jI_2 X_0 \quad (100)$$

Therefore

$$\frac{E_0}{E_p} = \frac{-jX_0 Z_m}{Z_p Z_s - Z_m^2} \quad (101)$$

In practice the primary is given a value that is approximately equal to the inductance of the loop antenna. The coupling between primary and secondary is the highest value that can be obtained. The secondary inductance is arranged so that the receiver will "track."

If Eq. (101) is expanded to include all the constants shown in the circuit of Fig. 74, a complex expression that is not easily interpreted results; however, by making the following assumptions it is possible to secure a satisfactory expression:

1. The reactance of the loop is exactly equal to the reactance of the primary of the coupling transformer
2. The ratio of reactance to resistance (Q) of the loop is equal to that of the transformer primary
3. The self-capacity of the loop and the capacity of the connecting cable are negligible
4. The coupling between primary and secondary is 100 per cent

Then it can be shown that

$$E_0 = E_g(-j) \sqrt{\frac{X_2}{X_L}} \cdot Q_L Q_2 \frac{1}{(2 - Q_L Q_2) + 2jQ_L} \quad (102)$$

From this formula it can be seen that the factors influencing the value of secondary voltage delivered are the ratio of secondary to primary reactance and the ratio of reactance to resistance of the primary and secondary elements. If it is assumed that the value of $Q_L Q_2$ is large compared with 2 or with Q_L , then Eq. (102) may be simplified to read as follows:

$$E_0 = E_g \cdot j \sqrt{\frac{X_2}{X_L}} \quad (103)$$

This equation would indicate that the greatest output from a low-impedance loop system is secured by the use of a coupling transformer having the greatest possible ratio of secondary to primary turns.

Since the inductance of a short winding varies with the square of the number of turns, and the voltage induced in a given loop with a given area and at a given frequency is proportional to the number of turns, it is evident that the best loop would have only a single turn. Such a loop would have the greatest effective height for a given inductance. This loop, however, would have such a low reactance that the characteristics of the transmission line could no longer be neglected; therefore, the optimum loop must have somewhat greater reactance. A commonly used loop for operation at low frequencies has an inductance of about 20 microhenrys.

An interesting deduction regarding the Q of a loop can be made by assuming that the coupling is accomplished by means of a perfect transformer. The equivalent circuit of a loop

coupled to such a transformer(6) is shown in Fig. 75. This figure shows a generator in series with three resistors and three reactors. Of the three resistors in this circuit, one is the resistance of the loop, the second the resistance of the primary winding, and the third the secondary resistance multiplied by the square of the ratio of primary to secondary turns. The reactance consists of the loop reactance and a reactance equal to the load reactance times the square of the ratio of primary to secondary turns. This load reactance is that of the tuning condenser. Since the receiver input tube is connected across this condenser, it is convenient to divide the second reactance into two units—the load reactance times the square of the ratio of primary to secondary turns minus the load reactance, and the

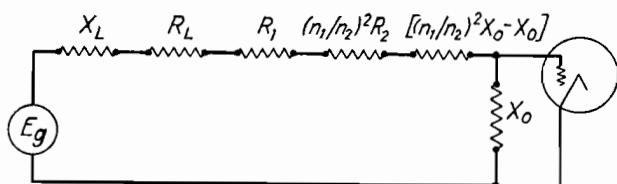

FIG. 75.—Equivalent circuit of low-impedance loop system assuming a perfect transformer.

load reactance across which the tube is connected. The condenser is varied until the voltage across it is maximum, at which time the circuit is in resonance, the series reactance is zero, and the current through it is equal to the generator voltage divided by the total resistance. The voltage applied to the grid of the tube is given by

$$E_0 = \frac{E_g X_0}{R_L + R_1 + (n_1/n_2)^2 R_2} \quad (104)$$

If it is assumed that (1) the primary reactance is equal to the square of the primary turns, (2) the secondary reactance is equal to the square of the secondary turns, and (3) the primary reactance is equal to the loop reactance, and if X/Q is substituted for the various resistances in Eq. (104), then the following expression results:

$$E_0 = E_g \frac{X_0}{X_1} \cdot \frac{Q_1 Q_2 Q_L}{Q_1 Q_2 + Q_2 Q_L + Q_L Q_1} \quad (105)$$

This equation indicates that the Q of the loop, the Q of the coupling transformer primary, and the Q of its secondary are all equally important in determining the voltage that the loop will

deliver to the grid of the first tube. It is further evident that the delivered voltage (as contrasted with that delivered by a high-impedance loop) will not vary directly with the Q of any one of the elements. A moderate improvement in the Q of any one element will not produce a large change in output. In order to illustrate this principle, a numerical example may be used. If it is assumed that the Q 's of the primary and secondary of the transformer are 200 and the Q of the loop is 100, then the value of the Q expression of Eq. (105) will be 50. If the Q of the loop is increased to 150, then the Q quotient of Eq. (105) becomes 60. That is, in this particular case a 50 per cent increase in loop Q brings about an increase in voltage of only 20 per cent.

The question of whether the high- or low-impedance loop has the best performance is often debated. The answer lies largely in the manner in which the individual loops in question are designed. If the only limitation was that the loops must be highly efficient, the same performance from either type could probably be obtained. For aircraft installations, a high-impedance loop with an amplifier located directly at its base can probably be designed to have the greatest performance for a given diameter. For compass work, however, the necessity for the amplifier and the attendant difficulty of installation and tracking easily offsets the slightly lower performance of the low-impedance loop. If the amplifier is not used directly at the base of a high-impedance loop, its performance will be less than that of a low-impedance loop unless the cable connecting the loop to the receiver can be made short or with very low capacity.

The Cardioid Field Pattern.—The figure-8 pattern has two maximum and two minimum positions. This dual indication is often undesirable. A field pattern having the form of a cardioid would be more desirable because there would then be but one maximum and one minimum.

Referring to Fig. 76, there is shown the familiar figure-8 pattern for which the equation has previously been written as

$$E = E_{\max} \cos \theta \quad (106)$$

In this expression, E is the voltage output of the loop having a maximum value of E_{\max} when the plane of the loop is in line with the direction from the center of the loop to the source of the radiant energy. A vertical antenna has equal output in the

horizontal plane for any angle between a plane containing the vertical antenna and the direction of the radiant-energy source. Its field pattern, therefore, is a circle, the equation of which can be written as

$$E = E_{\max} \quad (107)$$

If both a loop antenna and a vertical antenna are connected to the receiver and proper phasing and antenna output are present,

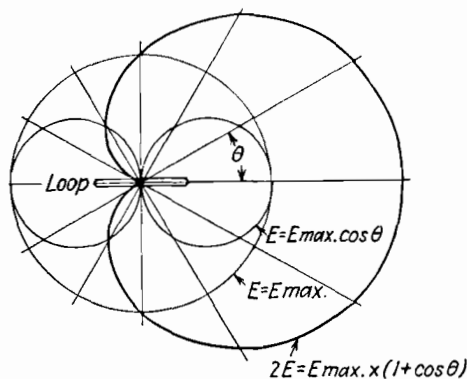

FIG. 76.—Generation of a cardioid field pattern from the combination of a vertical and a loop antenna pattern.

the field pattern of the resulting voltage must necessarily be the sum of Eqs. (106) and (107), or

$$2E = E_{\max}(1 + \cos \theta) \quad (108)$$

This, from analytical geometry, is the equation of a cardioid. If this field pattern is examined, it can be seen that there is now only one angle for which the output is maximum and only one for which the output is zero.

The Simple Direction Finder.—In its simplest form, the aircraft direction finder consists of a loop antenna (usually of the shielded type), a loop azimuth indicator, a radio receiver, a receiver tuning unit, and a loop rotating gearbox. The loop antenna is usually mounted to the airplane by means of a gearbox. This gearbox is of the speed-reduction type, and is actuated from the cockpit by means of a small, flexible torsion shaft. This torsion shaft terminates at a crank in the cockpit. To this crank there is also connected suitable gearing which serves to

rotate a pointer moving on a scale calibrated in degrees. The receiver is tuned to any desired station by means of the tuning control, then the loop is rotated until the signal disappears. The bearing obtained is compared with the magnetic compass so that its value as a function of true north may be known. It is then plotted on a suitable map. Two of these bearings, obtained from suitably located stations, serve to determine the location of the airplane. Positional information obtained in this manner is commonly called a "fix."

The bearing is obtained from the "null" rather than the maximum signal. This is done because the signal strength varies

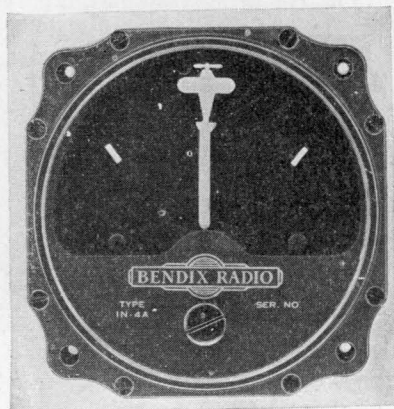

FIG. 77.—Indicator for the right-left radio compass. (Courtesy of Bendix Radio.)

only from 100 to 70.7 per cent as the antenna is rotated from the maximum to a position 45 deg. from the maximum; whereas, the signal strength varies from zero to a detectable finite value when the loop rotates only a few degrees from the zero-signal position. In this manner the bearing may be obtained with greater accuracy by noting the position of zero signal rather than determining the position of maximum signal.

Radio Compass.—In November, 1930, G. G. Kruesi applied for a United States patent on a device that later became known as a right-left radio compass(7). This patent was granted in July, 1932. The indicator for this device is shown in Fig. 77. If the nose (or the tail) of the airplane is pointed to the radio station, the indicator will point to the center mark. It will point to the right or the left as the airplane moves its nose or

tail from a position in line with the direction from the airplane to the radio station.

The device consists of a loop mounted so that its plane is at right angles to the major axis of the airplane. This loop is connected to a special radio receiver to which there is also connected a vertical antenna. Referring now to Fig. 78, there is seen a loop antenna connected to a receiver by means of a reversing switch. As this switch is thrown from side to side, the field pattern of the antenna system (which is adjusted so that it is normally a cardioid) reverses. If a meter having two opposing windings is connected to the rectified output of the

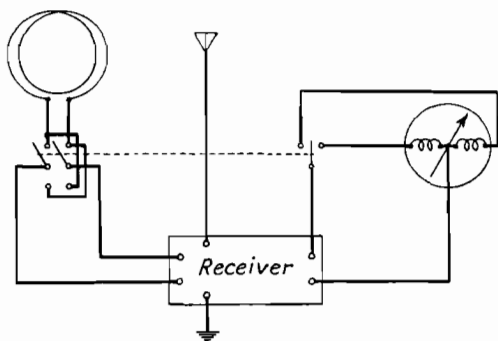

FIG. 78.—Principle of the right-left radio compass.

radio receiver and the connections to this meter are changed as the loop reversing switch is changed, the meter will move to the right, the amount of receiver output being thus indicated for one connection of the loop antenna. It will move to the left and thus indicate the amount of receiver output for the other loop-antenna connection. If the meter is reversed with sufficient rapidity, it will only deflect an amount proportional to the difference between the receiver output for the two loop connections. As shown in Fig. 79, a radio station is located at an angle θ from the major axis of the airplane. The amount of output for one loop antenna connection is a and for the second connection b . The amount b is greater than the amount a ; therefore, the meter will deflect to the right by an amount proportional to the quantity $b-a$. The actual amount of deflection will be a function of several factors. These instruments are generally adjusted so

that a deviation of only 5 deg. from directly ahead produces full-scale deflection of the instrument.

Actually, the reversing is done by means of an electronic circuit. This circuit consists of an oscillator connected to the grid of two tubes which are connected one to each side of a loop antenna having a center tap. When the oscillator voltage is a fixed negative value, one of these tubes is cut off and does not

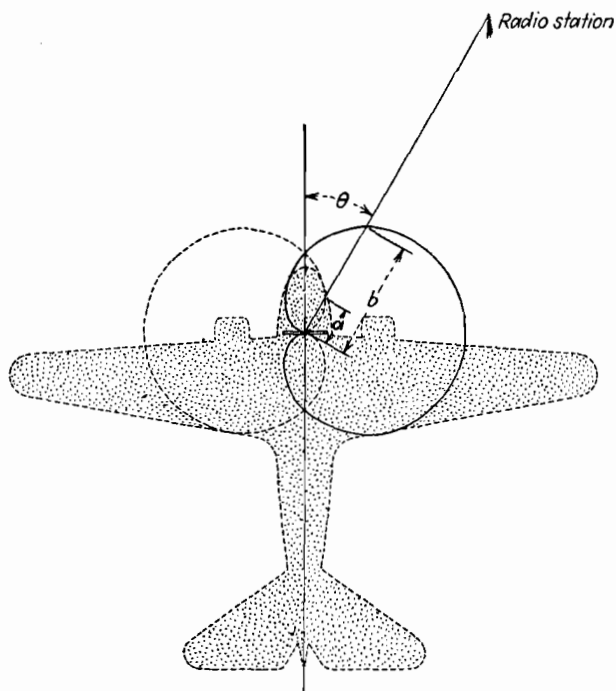

FIG. 79.—Use of compared cardioid patterns for indicating the heading of an airplane with respect to a radio station.

conduct until the oscillator cycle has reversed. Figure 80 shows the partial schematic diagram of a radio compass. The loop L is center tapped and connects to radio-frequency amplifier tubes V_1 and V_2 . To the grids of these same tubes is connected a push-pull audio oscillator consisting of the tubes V_3 and V_4 and the coil L_0 . This oscillator coil is also part of the indicating meter I .

This coil is tuned by means of a condenser C_0 so that the audio frequency has some low value. This frequency varies from

40 to 90 cycles for different makes of receivers. The voltage from the audio oscillators, then, alternately cuts off the grids of the tubes V_1 and V_2 forty to ninety times per second. The energy from these radio-frequency amplifiers is alternately fed to the radio receiver where it is mixed with the energy from the fixed antenna A . The output of the receiver is rectified; hence the resultant is also an audio voltage with a frequency similar to that of the oscillator. This output voltage is connected to the other coil of the indicator which actually serves as a phase meter and moves the pointer in a manner that is a function

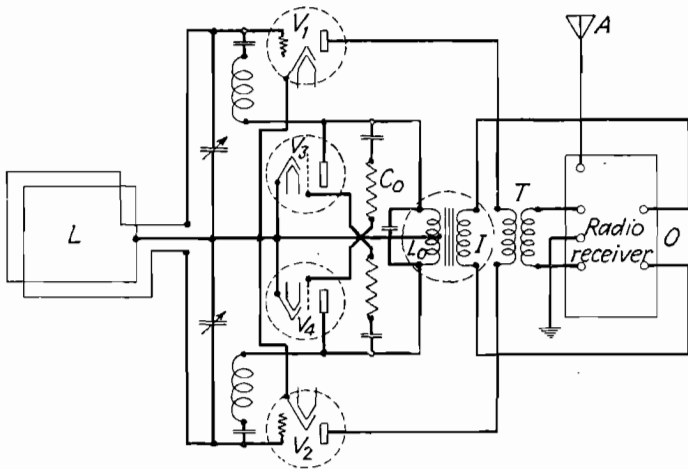

FIG. 80.—Simplified schematic of right-left radio compass.

of the relative intensity of the energy picked up by the two cardioids. Although the sensitivity of these compasses is not exceptional, the rectifier output is tuned to the audio frequency at which the receiver is reversed, and in this manner the effect of static is minimized and the radio compass will indicate with phenomenally poor ratios of signal to noise.

Automatic Direction Finder.—The right-left radio compass was never widely adopted by the commercial air-transport operators. One of the reasons for this can be understood by referring to Fig. 81. In this figure an airplane using a radio compass is avigating in an attempt to reach radio station R and encountering a strong wind blowing directly across its course. The pilot takes no recognition of the wind but continues to fly, keeping his compass indicator on the center of the scale

and hence the nose of the airplane pointed to the station. As time passes, the wind blows the airplane from the direct path between its first position and the radio station, but the airplane continues to keep its heading directed toward the station; however, in so doing it traverses a path much longer than the shortest path between its starting point and destination. Of course if the airplane has sufficient fuel and the longer path flown has no obstructions, it eventually reaches the station. The transport pilots must fly with much greater precision, and many of them say that they can fly as well with a magnetic as with a radio compass. It is not only necessary for the pilot to know

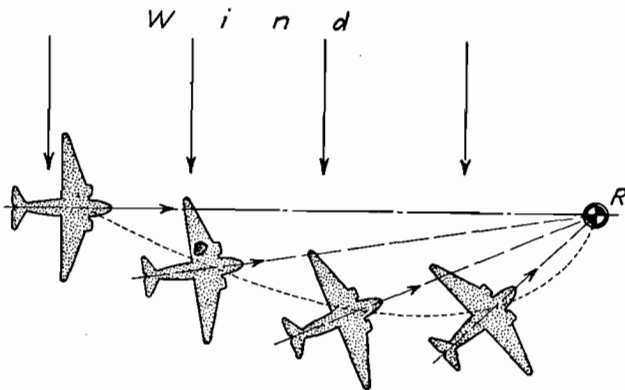

FIG. 81.—Flight path resulting by avigation with a right-left radio compass in the presence of a strong cross-wind. No reference was made to magnetic compass heading.

where he is going, but also he must know his exact position. Of course the path shown in Fig. 81 can be minimized by continually referring to a magnetic compass, but this procedure detracts from the usefulness of the radio compass. This device has application for certain private and military uses.

On Oct. 22, 1937, F. L. Moseley applied for a patent(8) on a device having the radio compass as its basis of operation. Several devices of this type have been developed and have found wide acceptance by the airlines. As shown in Fig. 82, electrical contacts have been added to the compass indicator on either side of the moving needle. As the needle touches one of the contacts (by virtue of the fact that the radio station is to one side of the airplane's heading) a motor is set in motion. This

motor serves to rotate the loop which, as contrasted with the radio compass loop, is now rotatable. This motor rotation continues until the plane of the loop is at right angles to the direction from the airplane to the radio station actuating the pointer. At this point, the needle returns to zero and the motor stops. A flexible shaft connecting between the loop and the cockpit shows the position of the loop at all times and hence indicates the bearing between the airplane's heading and the

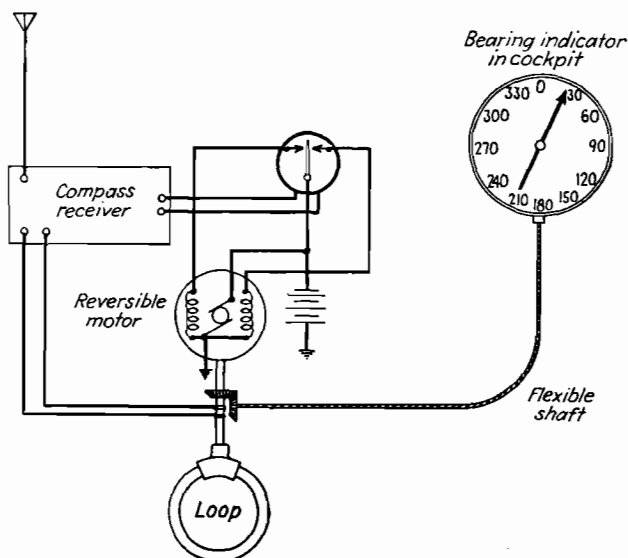

FIG. 82.—Principle of the automatic direction finder based on the right-left radio compass.

radio station. Bearings of this kind taken on a station off the radio range's course when the airplane is flying in the on-course zone gives the pilot his position. If he is not directly on-course, bearings from two or more stations give the necessary position. Regardless of the location of the airplane, positional information is available without maneuvering. This device, then, enables the pilot to fly where he wishes without respect to range course.

Of course the circuit of Fig. 82 merely serves to illustrate the principle, and, actually, electronic circuits are substituted for the contact mechanism described above. A number of problems must be solved in constructing one of these automatic direction

finders. The loop must not overshoot its mark, but, if it does, it must return to the correct position. The exact circuits used are listed in the instruction books of the various manufacturers of these devices.

The Busignies Automatic Direction Finder.—This device(9), also bearing type designation RC-5, is the product of Les Laboratoires le Matériel Téléphonique of France, and, although it

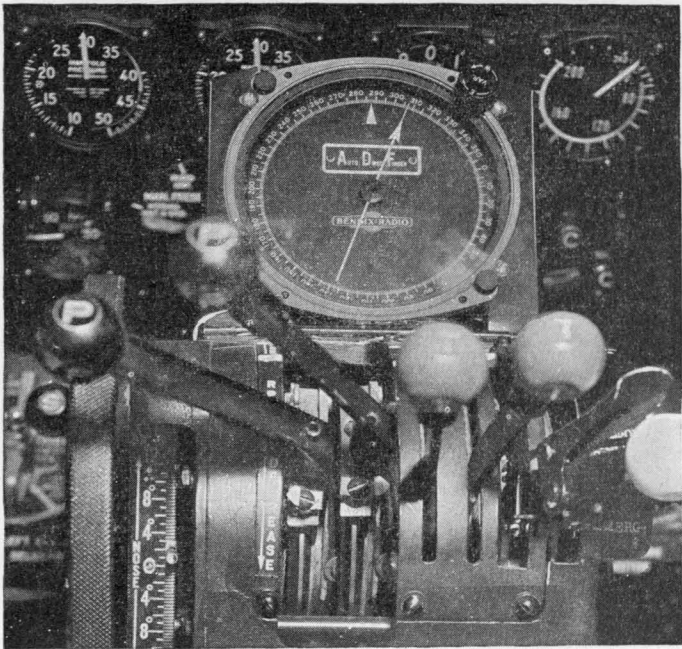

FIG. 83.—Automatic direction-finder indicator installed in the cockpit of a transport airplane. (Courtesy of United Air Lines.)

has not been extensively used in this country, it has been test flown here, and only the timely development of the automatic direction finder previously described prevented its adoption. Nevertheless, it makes use of a very interesting principle which, if further developed, might result in a product having characteristics equal to the type previously described.

In this device a loop is continuously rotated about a vertical axis at a constant speed of 300 r.p.m., and the output of the receiver is rectified. Whenever the plane of the loop is in line

with the direction between the airplane and the radio station, the rectified output will be maximum, and at right angles to this position it will be minimum. The rectified output, when impressed on the primary of a transformer, will produce an alternating voltage wave at the output terminals of the transformer. Notice that the maximum of the voltage is a function of direction of the radio station. This maximum occurs (as previously stated) whenever the plane of the loop contains the line between the center of the loop and the radio station.

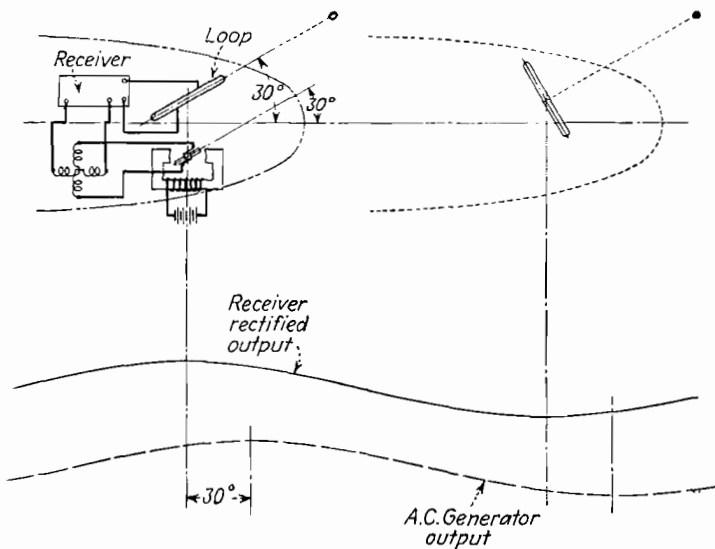

FIG. 84.—Principle of the Busignies radio compass.

To the shaft that rotates the loop there is also attached an alternator. The voltage generated by this alternator will have maximum and minimum as a function of the position of its pole pieces. That is, if its pole pieces are in line with the major axis of the airplane, there will be maximum voltage produced whenever the plane of the alternator armature coil is in line with the major axis of the airplane. These maximums and minimums always occur at the same point with respect to the axis of the airplane because the alternator is attached to the airplane structure. A meter showing the phase existing between the voltage at the output of the radio receiver and that at the output of the

alternator will then read the bearing in degrees existing between the major axis of the airplane and the radio station. This scheme is shown in graphic form in Fig. 84. It is not possible to filter the output of this device as was done with the right-left compass in order to secure operation under conditions of high noise. This is because the loop is rotated by means of a direct-current motor, deriving its power from the battery of the airplane, and therefore does not operate at constant speed. The voltage at the receiver terminals, consequently, would not have a constant frequency, and if a filter were used, a phase shift would

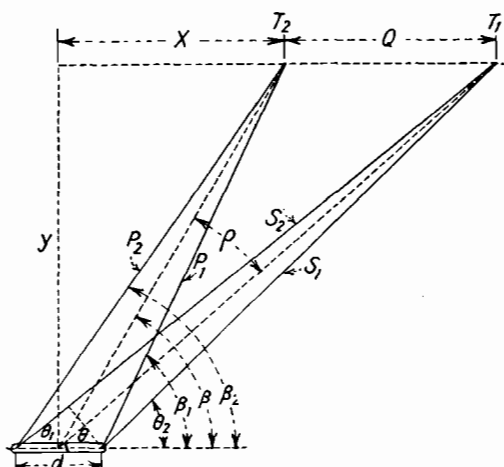

FIG. 85.—Loop taking bearings when close to a range station. The individual towers induce individual voltages in the sides of the loop.

occur. Since the indicator reads bearings in terms of relative phase, a bearing error would occur whenever the speed of the motor changed. A beat-frequency oscillator is used in order to improve the signal-to-noise ratio under which this device will give satisfactory operation.

Since there are two positions where the loop output is maximum, the bearings will be ambiguous by 180 deg. That is, where the radio compass reads 30 deg., the bearing may be 210 deg. In the actual design a direct-current potentiometer is used to generate the alternating current. This generator produces two current waves 90 deg. out of phase. These currents flow through two windings of the indicator, which are wound in

space 90 deg. to each other. The output of the receiver is then connected to a third indicator coil mounted on pivots so that it may assume a position that is a function of the relative phase between the current through it and that through the stationary coils.

Direction-finder Errors When Using Range Stations.—In the development of the equations for the output of the loop receiving and transmitting antennas it was assumed that the source of the received energy, or the sink of the transmitted energy, was at a great distance from the directive antenna. When this assumption is not valid, certain errors are introduced. As shown in Fig. 85, a loop antenna is located at a position X, Y from a two-tower antenna system. From tower T_1 it has been shown that the voltage induced in the loop antenna will be

$$E_{T_1} = E_{\max} \cos \theta \quad (109)$$

and from tower T_2

$$E_{T_2} = E_{\max} \cos \beta \quad (110)$$

In this expression it is assumed that the diameter of the loop is very small compared with the distance from the loop to the transmitting antenna, so that

$$\theta_1 = \theta_2 = \theta \quad (111)$$

and

$$\beta_1 = \beta_2 = \beta \quad (112)$$

If the angle between a line drawn from each tower and the center of the receiving loop is ρ , then

$$\beta - \theta = \rho \quad (113)$$

Substituting Eq. (113) in Eq. (110),

$$E_{T_2} = E_{\max} \cos (\rho + \theta) \quad (114)$$

Considering the energy from a single tower only, the loop will have zero pickup when θ or $\rho + \theta$ equals 90 or 180 deg., and this value of angle with respect to a fixed point determines the bearing.

Although the currents flowing in the towers are 180 deg. out of phase, this phase relationship is altered at the point of reception, because the energy from one tower travels a greater distance than the energy from the other tower and in so doing it

suffers a phase retardation equal to ϕ . The resultant voltage is then the vectorial sum of the voltages induced in the loops by the energy from the individual towers. Referring to Fig. 86, the resulting voltage E_R will be

$$E^2_R = E^2_{T_1} + E^2_{T_2} - 2E_{T_1}E_{T_2} \cos \phi \quad (115)$$

or

$$E^2_R = E^2 \cos^2 \theta + L^2 \cos^2 (\beta + \theta) - 2E^2 \cos \theta \cos (\beta + \theta) \cos \phi \quad (116)$$

Making θ equal to 90 deg. no longer reduces the output to zero. It is necessary that

$$\cos^2 \theta + \cos^2 (\beta + \theta) = 2 \cos \theta \cos (\beta + \theta) \cos \phi \quad (117)$$

At very great distances, ρ and ϕ will approach zero and β will equal θ ; then a value of 90 deg. for θ will make the output zero.

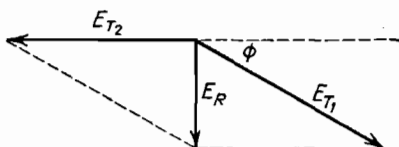

FIG. 86.—Vectorial summation of voltages induced by range towers in loop sides.

As the station is approached it can be seen that there must be an appreciable variation of θ from its 90-deg. value in order to make the output zero. This variation is a bearing error.

Characteristics of Compass Receivers.—It has been previously shown that the cardioid field pattern is obtained by adding directly to the field pattern of a loop antenna the pattern of a nondirectional antenna, but it has also been shown that the voltage output of a loop antenna is 90 deg. out of phase with the voltage output of a vertical antenna. Therefore, one of the problems that must be solved in the design of a compass receiver is the satisfactory construction of a phase-shifting device that will shift the phase of the voltage of the loop or the antenna by 90 deg. It is readily possible to design such a circuit for single-frequency operation; however, the problem becomes difficult when applied to a receiver that must tune over a wide band such as 550 to 1,500 kc. If a number of tuned circuits follow the loop

or vertical antenna, but are not common to both antennas, slight variations in the tuning of these circuits may produce a phase shift that will distort the field pattern and cause the indicator needle to reverse its indication. The first rule to be followed in compass-receiver design, therefore, is to keep to an absolute minimum the number of tuned circuits not common to both the nondirectional antenna and the loop. Preferably not more than one such circuit should be used. A number of phase-shifting circuits have been devised. The one most commonly used consists of a coil and condenser in parallel inserted in the plate circuit of an amplifier tube associated with either the loop or the vertical antenna. The value of this coil and condenser is so chosen that the result is an inductive reactance over the entire frequency band. If more than one frequency band is incorporated in the receiver, it is sometimes necessary to have a different condenser and coil combination for each band. This circuit is not tuned during the tuning of the receiver. The condenser and coil constants are established at the time of original design and are not changed thereafter.

It is very necessary that the amount of regeneration in a compass receiver be kept to a figure far below that permissible in the usual receiver. Regeneration in a compass receiver may have such a low value that it cannot be detected by the usual methods, and still it will affect the compass operation. This is because regeneration produces a phase shift which, as has previously been discussed, causes bearing errors. Since regeneration usually varies over the tuning range, the phase shift, and hence the bearings, would vary with frequency. The behavior of the compass for various values of input signal is the best criterion of this regeneration condition. Traces of erratic pointer operation should be investigated to determine if they are caused by regeneration. Extreme care in shielding should be embodied in the design of this receiver. The practice of returning all grounds to a common point should be carefully observed.

The sensitivity of compass receivers varies with different models. This sensitivity is usually 1 to 5 μ v with a signal-to-noise ratio of 6 db and a standard output of 50 mw. An automatic direction finder using a receiver with this characteristic will repeat bearings to within $\frac{1}{2}$ deg. with field strengths of

5 to 20 μv per meter when the pointer is started 180 deg. from the true bearing.

It is important that the selectivity of these devices be high, otherwise a signal on an adjacent channel will cause false pointer deflection or false bearings. The selectivity should be such that the attenuation shall be at least 60 db when the band width is not greater than 15 kc. Rejection of the image frequency, as well as all other spurious responses, should be high. This rejection should be at least 80 db.

An automatic gain control should be incorporated in the receiver. As the loop antenna is rotated so that it approaches the null, the signal is greatly reduced and an increase in gain is necessary in order that there shall be sufficient receiver output to actuate the motor controlling mechanism. If the receiver were allowed to operate continuously at full gain, overloading would occur and cause false bearings. An automatic gain control that will hold the output constant to 5 db for input-signal levels varying from 10 to 100,000 μv is satisfactory. The weight of a complete automatic direction finder is about 60 lb.

Testing Radio Compasses and Direction Finders.—The Institute of Radio Engineers has established as a standard method for measuring the performance of receivers using loop antennas the use of a loop placed coaxially with the loop of the receiver under test and at some distance from it. The field strength is then given by

$$\epsilon = \frac{18.9N_1A_1^2}{X^3} I_1 \quad (118)$$

where ϵ = equivalent electric field intensity, microvolts per meter

N_1 = number of turns in the test loop

A_1 = radius of transmitting loop, centimeters

X = distance in meters between transmitting and receiving loop. This distance should be small compared with the distance between the loop and the screen-room wall

I_1 = current in transmitting loop expressed in milliamperes

A method (10) developed by the United States Army is more commonly used for laboratory measurements on receivers. In this system (see Fig. 87), a transmission line consisting of a single wire is mounted horizontally between two walls of a screen room. To

one end of the line there is connected a signal generator and to the other end a resistor with its second terminal connected to the wall of the screen room. The loop under test is mounted beneath this wire in such a position that if its vertical axis were extended it would intersect the wire at right angles.

If the center of the loop is located d in. from the wire, and the wire is located d_f in. from the floor and d_c in. from the ceiling, the

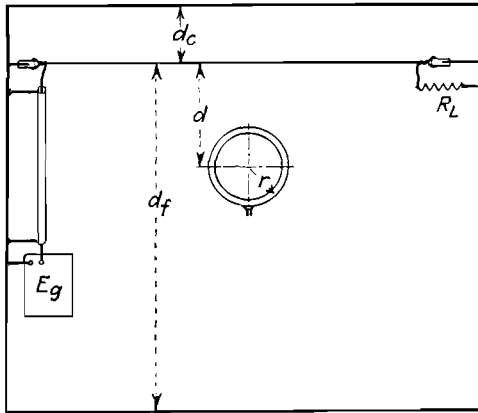

FIG. 87.—Method of testing loop direction finder in screened room using a terminated transmission line.

field strength in microvolts per meter at the center of the loop will be

$$E = 2,360 \frac{E_L}{Z_L} \left(\frac{1}{d} + \frac{1}{2d_f - d} - \frac{1}{2d_c + d} \right) \quad (119)$$

In this expression, E_L is the voltage introduced from the signal generator and Z_L is the impedance of the transmission line. This transmission-line impedance is determined by connecting a radio receiver to the line by means of a clip. The terminating resistor is varied, and the clip is moved along the wire.

That value of resistance for which the voltage has the same magnitude at any point along the wire is the characteristic impedance of the line. If the output impedance of the signal generator is appreciable, a correction must be made as follows:

$$E_L = \frac{E_g}{Z_g + Z_L} \quad (120)$$

In this expression, E_o is the voltage read on the scale of the signal generator and Z_s is its output impedance.

The field strength all about the circumference of the loop antenna will not be the same as the field strength at its center. For a round loop the following correction applies:

$$E_{av} = E \cdot \frac{2d(d - \sqrt{d^2 - r^2})}{r^2} \quad (121)$$

In this expression, E_{av} is the average voltage and r the average loop radius in inches.

For a square loop, the correction is given by

$$E_{av} = E \cdot \frac{d}{2L} \log_e \frac{d + L}{d - L} \quad (122)$$

In this expression, the square loop is assumed to have sides with a dimension in inches equal to $2L$.

For a given set of conditions, the preceding formulas can be used to calculate a constant by which the reading of the signal generator may be multiplied in order to obtain the field strength at the loop in microvolts per meter, and further calculations are then greatly simplified.

Aircraft Installations and Quadrantal Errors.—Loops on aircraft are usually mounted either above or below the fuselage, although some installations have been made in which the loop is mounted in the plastic nose of the airplane. Europeans have made installations in which one half of the loop was mounted within the fuselage of the airplane. As will be discussed later, the mounting of the loop below the fuselage has an advantage in the reception of the "null" signal from a range station. Other than this there is small choice between mounting positions with regard to the top and bottom of the fuselage. Both positions give about the same amount of quadrantal error. The position on the nose gives too great an error unless the nose is large and permits the loop to be mounted far in front, away from the fuselage. Here the error is still great, but it may be tolerated. This quadrantal error is an apparent deviation in the direction of arrival of the radio wave. Since the modern airplane is a nonuniform metal structure, it serves to pick up energy or act as a shield for it; consequently, for certain positions of the loop, the actual amount of signal will be greater or less

than that for other positions. All loop installations must be calibrated for this error.

This correction must be determined with the airplane in normal flight and at least two wave lengths away from a radio station. A distance that is large as compared with the radius of airplane turn is desirable, but this distance must not be so great that course bending or night effect is present. The airplane circles a known point while the radio bearings are taken

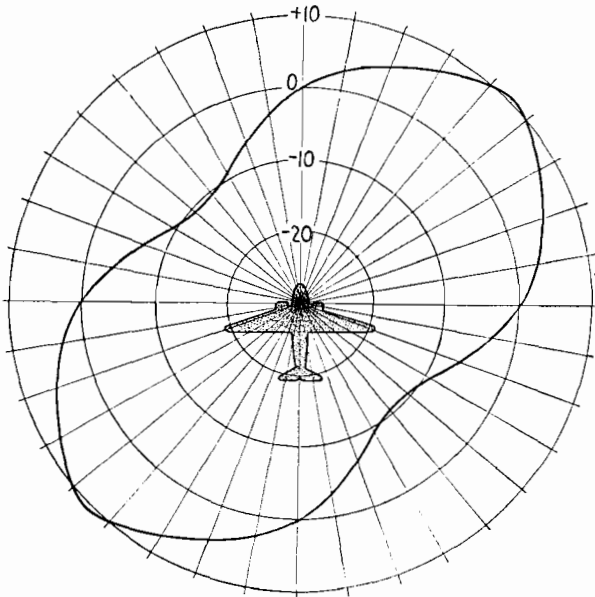

FIG. 88.—Quadrantal error of an airplane direction finder.

and compared with those from a directional gyro. This determination is comparatively simple for an automatic direction finder, but many data must be taken with a manual direction finder in order to obtain one set that can be considered reliable (see Fig. 88).

After the quadrantal error is known, it can be used in several ways. The simplest method involves the use of an azimuth card mounted so that it bears a fixed relation to the airplane's structure. In this type of installation, it is necessary only to "squeeze" together and "spread" apart the degree marks on the scale to conform with the error data previously determined.

This is not a very satisfactory solution, however, because it is desirable to be able to rotate the azimuth scale to conform with the airplane's magnetic heading and thereby eliminate the necessity for calculations when converting the radio bearings in terms of the true magnetic bearing.

Another solution consists in plotting the curve on a separate chart located around the periphery of the azimuth card. This chart is mounted in a fixed relation to the airplane's structure, but the azimuth scale is free to rotate. The error is read from this chart for any position of the direction-finder pointer. This solution necessitates addition or subtraction and has little advantage over the one previously described. The best solution incorporates a cam arrangement in the loop-rotating mechanism so that the pointer advances or retards with loop rotation from the bearing representing the position of the loop. This cam is cut to fit the particular set of data associated with the airplane on which the loop is mounted. One manufacturer has a cam made of a spring adjustable by means of a large number of screws. This cam is located at the azimuth indicator in the case of the manual loop, but since some of the automatic loops are driven by Selsyn motors and therefore have little power, the cams for the automatic direction finders are located near the loops so that they can be actuated by the loop-rotating motor.

Problems

1. A receiving-loop antenna has a diameter of 12 in. and is wound with 30 turns. Its inductance is 1,530 microhenrys and it has a Q of 300. It is tuned with a condenser across the winding, with one end of the winding connected to ground and the other to the grid of a tube. What voltage will it deliver to the grid when it is in a field of a 300-kc. transmitter, the field strength of which is 20 μv per meter?

2. A low-impedance antenna connected as shown on Fig. 74 has the following constants:

$$X_1 = 20 \text{ microhenrys, } Q = 100$$

$$X_c = 0$$

$$X_1 = 20 \text{ microhenrys, } Q = 60$$

$$Z_m = 200 \text{ microhenrys, resistance zero}$$

$$X_2 = 2,500 \text{ microhenrys, } Q = 250$$

The loop has a diameter of 10 in. and is wound with six turns. It is in a field of a 300-kc. transmitter which has a strength of 300 μv per meter. Calculate the output voltage E_o .

3. Refer to Fig. 85. In this figure, $X = 2,500$ ft., $Y = 1$ mile, and $Q = 500$ ft. The transmitted energy has a frequency of 300 kc. Compute

the bearing error resulting from taking a "null," assuming that the bearing to the center of the antenna array is desired.

4. Refer to Fig. 87, and compute the correction factor by which the dial reading from the signal generator is to be multiplied in order to obtain average field strength at the loop if the transmission line has an impedance of 525 ohms, the signal generator has an output impedance of 100 ohms, the loop under test has its center 3 ft. from a transmission line 1 ft. from the ceiling, the screen room has a 7-ft. ceiling, and the loop has a 12 in. diameter.

Bibliography

1. MARRIOTT, R. II.: Radio Range Variation, *Proc. I.R.E.*, Vol. 2, pp. 37-52, March, 1914.
2. MORGAN, H. K.: Rain Static, *Proc. I.R.E.*, July, 1936, p. 959.
3. HUCKE, H. M.: Precipitation-static, Interference on Aircraft and at Ground Stations, *Proc. I.R.E.*, May, 1939, p. 301.
4. STARR, E. C.: Precipitation Static Radio-interference Phenomena Originating on Aircraft, *Oregon State College Eng. Expt. Sta. Bull.* 10.
5. EVERITT, W. L.: "Communication Engineering," p. 201, McGraw-Hill Book Company, Inc., New York, 1932.
6. EVERITT, W. L.: "Communication Engineering," p. 210, McGraw-Hill Book Company, Inc., New York, 1932.
7. KRUESI, G. G.: Radio Direction Finder, U.S. Patent No. 1,868,945, July 26, 1932.
8. MOSELEY, F. L.: Radio Compass Navigation Apparatus, U.S. Patent No. 2,257,757, Oct. 1, 1941.
9. BUSIGNIES, H.: The Automatic Radio Compass and Its Application to Aerial Navigation, *Elec. Communication*, October, 1936.
10. FRAMME, R. J.: Radio Compasses Principles and Testing, *I.R.E. 14th Annual Convention*, Sept. 22, 1939.

CHAPTER V

MARKERS

When the radio ranges were first established, they were intended as a means for guiding aircraft, but not necessarily under those conditions when normal visual guidance fails. That is, ranges were not intended to allow the flying of airplanes in weather that would not permit flying without ranges. It was intended that after an airplane had used the range to reach a destination the weather would be favorable at the terminal and the pilot would readily recognize the landing field and complete his flight. All this, however, was changed shortly after the ranges were installed. The pilots found that guidance was present when flying above an overcast when the ground could not be seen, but a means for indicating the terminal was required. No attempt had been made for providing such an indication when the range was originally developed, but such an indication was present in the form of a phenomenon that had not been anticipated. When the airplane flew directly over the transmitting array, the coupling between the receiving and the transmitting antennas momentarily became zero, and this loss of signal, later named "the cone of silence," served as a terminal marker. In order to determine the position along a range where it was necessary to execute some maneuver, a radio range, the course of which intersected the range course being flown, was tuned in (preferably on a second receiver), and when the on-course signal of the second range was heard the desired maneuver was executed. Later, course markings to indicate a turning point were installed in the form of miniature radio ranges and low-powered stations operating on 278 kc. The problem is similar to motoring over a fine system of highways that have no signposts. These signposts are necessary to make the highways useful.

Cone of Silence.—The exact location of the terminal radio station is of extreme importance because it serves as the reference

point from which a pilot originates a maneuver calculated to bring him through the overcast and directly over the airport. These maneuvers, known as "approach procedures," are carefully developed by the chief pilots and prescribed in detail for use by pilot personnel at each terminal.

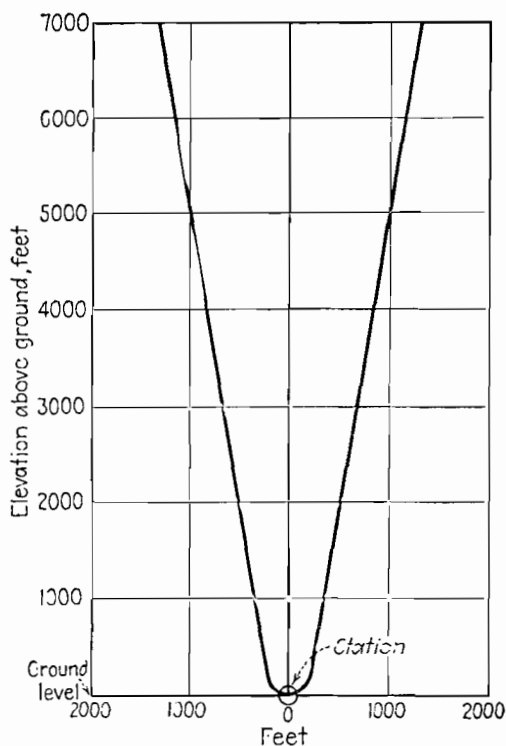

FIG. 89.—Cone of silence of a miniature radio range.

As was previously stated, the presence of this important marker was due to chance and by virtue of the fact that there is a point of zero coupling between the transmitting and receiving antennas. This being the case, these and other characteristics of this marker are a function of both the transmitting- and receiving-antenna characteristics. Such an area of silence is shown in Fig. 89. The data for Fig. 89 were obtained from flights over a miniature range station employing small loop antennas.

As an airplane approaches a range station, the signal strength increases; so the pilot reduces the gain of the receiver in order to maintain a comfortable audio level in his headphones. Just as the station is reached, there will be a momentary increase in signal followed by a cessation of signal and then another

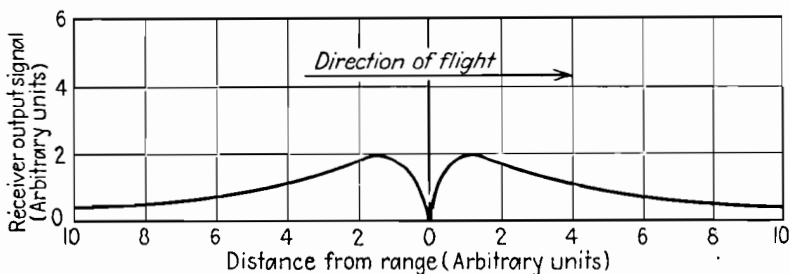

FIG. 90.—Cone of silence with vertical receiving antenna. (Courtesy of Institute of Radio Engineers.)

signal increase. If the antenna is perfectly nondirectional, a plot of signal versus distance will be as shown in Fig. 90. If, however, the antenna has other characteristics, almost complete obliteration of this indication(1) such as shown in Figs. 91 and 92, may be obtained.

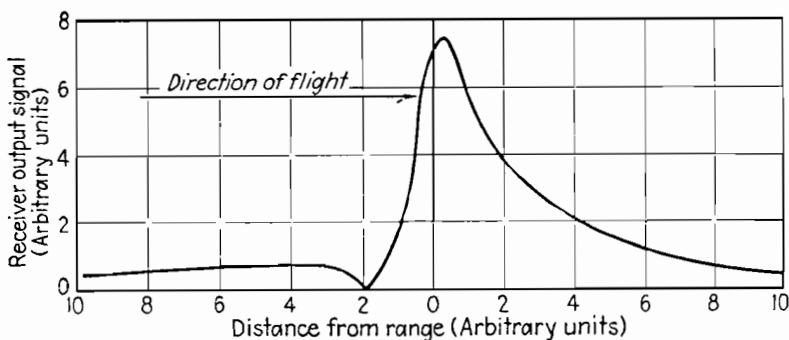

FIG. 91.—Cone of silence resulting when receiving antenna was inclined 30 deg. (Courtesy of Institute of Radio Engineers.)

This pattern also varies with the transmitting array and is affected by the presence of near-by objects. Thus, Figs. 93 and 94 show the cone(2) for the same range but employing two different course alignments. In Fig. 93 the presence of some railroad tracks caused bending of the courses.

Although the preceding characteristics must be considered when designing range transmitting and receiving antennas, the cone of silence has some objections that cannot be corrected by design. Since it is a "null" type of indication, the momentary

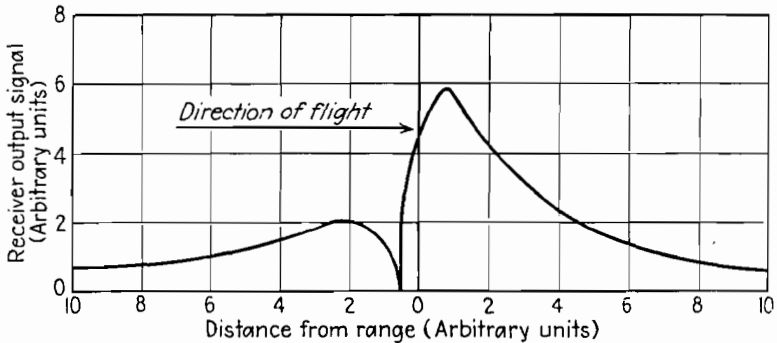

FIG. 92.—Cone of silence resulting when receiving antenna was inclined 60 deg. (Courtesy of Institute of Radio Engineers.)

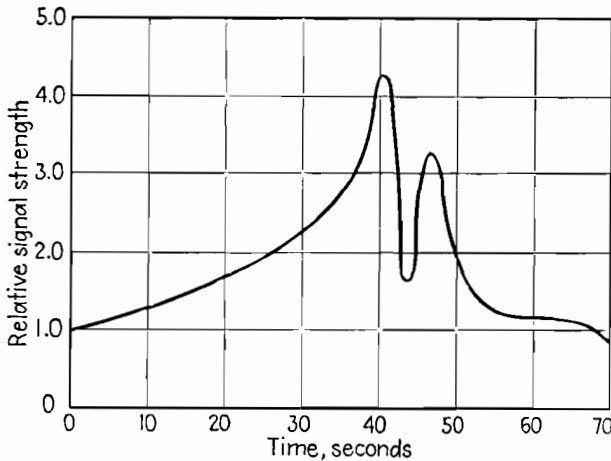

FIG. 93.—Distortion in the cone of silence caused by an object adjacent to the radio range. (Courtesy of C.A.A.)

disappearance of the signal, owing to a fault in either the transmitter or receiver, will produce essentially the same indication as the true cone.

Particularly in mountainous country the normal signal variation caused by the terrain can easily be mistaken for a "cone." Although this cone indication is being received where the field

strength of the transmitter is great, it is, nevertheless, affected by severe static.

The approach to the cone is generally made at a low altitude. Figure 89 is the diagram of what is considered a "good" cone. This diagram shows that the width of the indication is only about 1,200 ft. at an altitude of 3,000 ft. A pilot attempts to find the cone by flying at a minimum speed. For a modern airplane, this speed is about 120 m.p.h. This means that the indication is present for only 7 sec. On the simultaneous ranges the indication attains for a shorter time.

Z Marker.—In order to correct the difficulties attending the cone indication, there was installed and commissioned on Jan. 1,

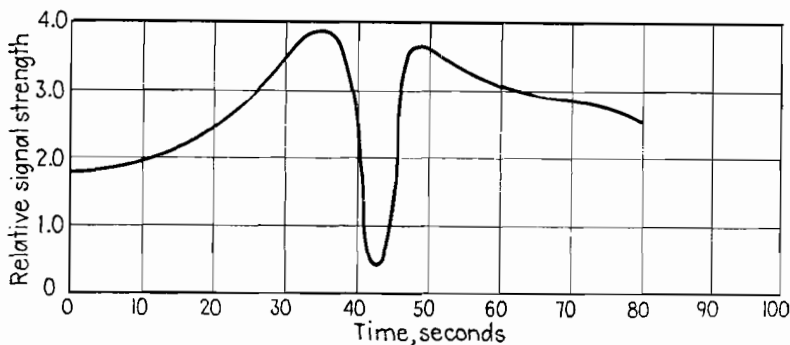

FIG. 94.—Normal simultaneous radio-range cone of silence resulting when the course alignment of the range (the cone of which is shown in Fig. 93) was changed. (Courtesy of C.A.A.)

1939, on the airways of the United States a different type of terminal indication known as the Z marker. This marker consists of a new type transmitter(3) on the ground actuating a separate receiver on the airplane. Primarily the indication in the cockpit consists of a light that illuminates as the airplane passes over the transmitting array, but an aural indication in the form of a continuous 3,000-cycle tone is also heard slightly before and after the light signal is observed. The pattern of this indication is a function of the receiver sensitivity. The usual commercial-transport receiver sensitivity is adjusted in the service shop to about 2,500 μ v with the use of an artificial antenna. With a receiver so adjusted, the pattern of Fig. 95 results. Referring to this figure it will be seen that the pattern

width is now about 1.5 miles at an altitude of 3,000 ft., thus the new indication is much broader than the older type. Figure 95 also shows that there is a "top" at which this new indication is no longer received. This top can be extended by increasing the receiver sensitivity; however, such an adjustment also brings

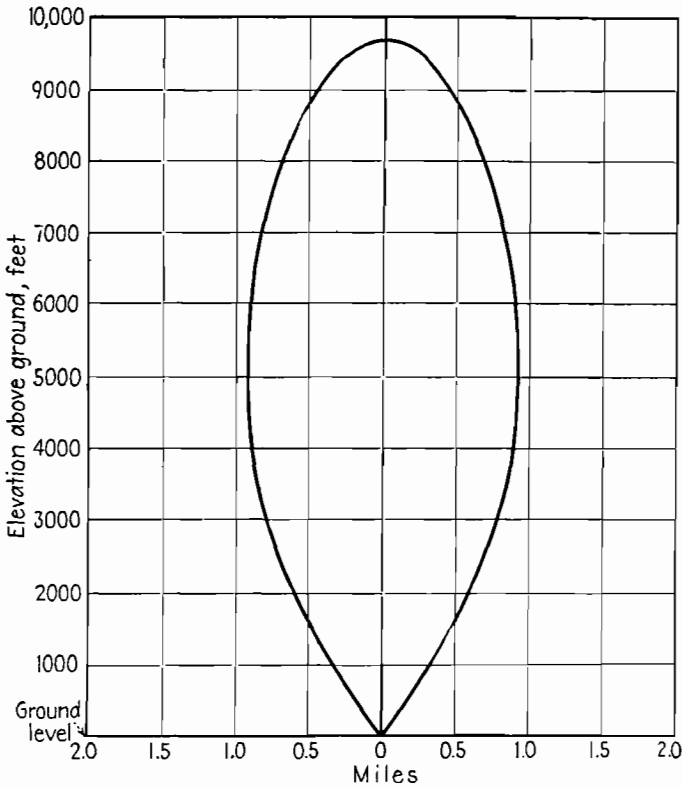

FIG. 95.—Vertical space pattern of the 75-megacycle Z marker.

about an increase in width which is undesirable. This is shown in Fig. 96. This new indication operates on 75 megacycles and enjoys great freedom from static. There has been no case where the operation of this indication has been hampered by atmospherics in any form.

The Z Transmitter.—The transmitting equipment employed for supplying this indication consists of a dual transmitter having a nominal output of 5 watts. The transmitters are so arranged

that the antenna array is connected from one to the other if a failure occurs. They are crystal controlled and employ a 6.250-megacycle crystal. Besides the oscillator and the output stage, two tubes are employed to multiply the crystal frequency to 75 megacycles. The modulation is accomplished by tube oscillators and amplifiers.

Z Transmitting Antenna.—In the formation of the space pattern, the antenna array is all-important. The array devel-

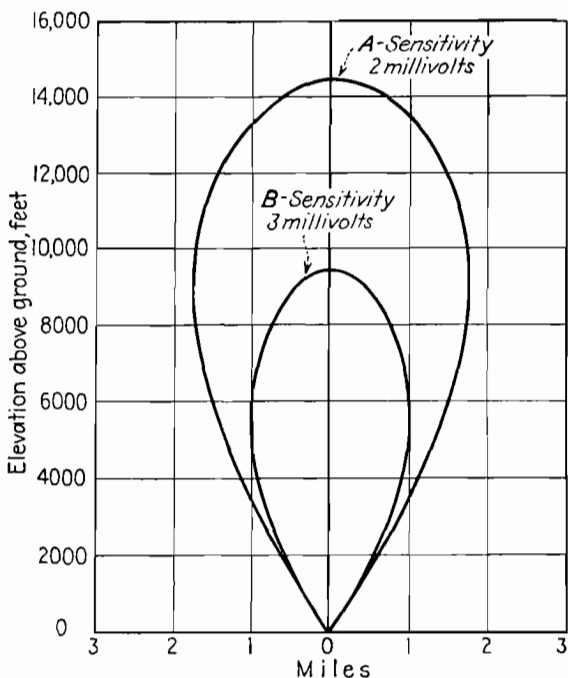

FIG. 96.—Variation in Z-marker pattern with change in receiver sensitivity.

oped consists of four horizontal half-wave elements. These elements are connected to the transmitter by means of a transmission line. The length of line connecting to one pair is one-quarter wave length longer than that connected to the other pair. In this manner essentially circular polarization results. The plan pattern resulting with this array is shown in Fig. 97. This array is mounted one-quarter wave length above a wire screen which serves to project the energy upward. This screen

is mounted one-half wave length above the ground; thus the growth of vegetation, the accumulation of snow, etc., occur

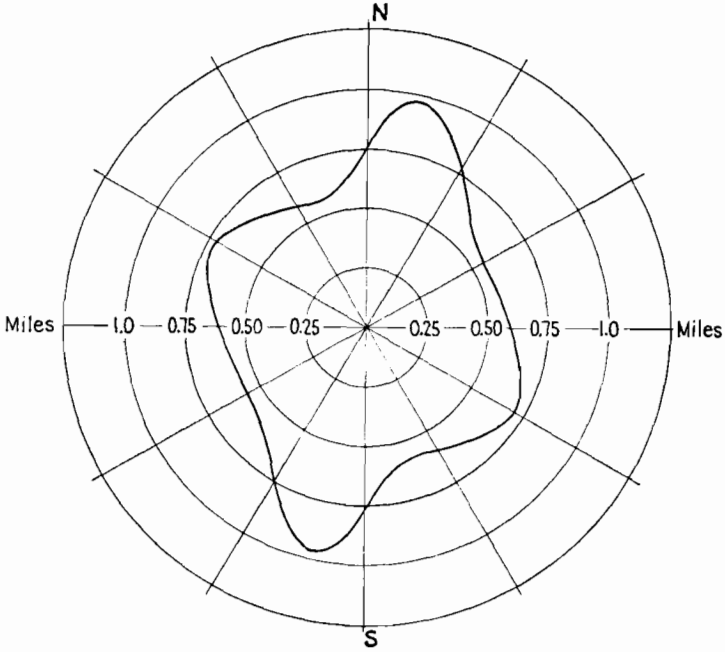

FIG. 97.—Plan pattern of Z marker.

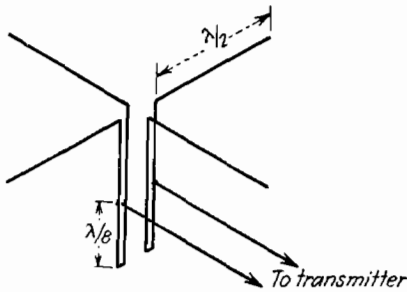

FIG. 98.—Antenna used for producing Z-marker pattern.

below the screen and do not affect the characteristics of the marker. This antenna is shown in Figs. 98 and 99.

Fan Markers.—Additional markers have been required along an airway because of the increase in traffic and its method of

control necessary in order to avoid collision. The airplane now reports as it reaches definite points along the airway, and each time that this is done it receives, from a government group known as Airways Traffic Control, permission to proceed to the next point on the airway. This procedure minimizes the possibility of collision.

Although the intersection of two ranges constitutes a fairly satisfactory marker, the low-frequency nondirectional stations operating on 278 kc. could not define an accurate area because of the effect of static. These low-frequency facilities have been replaced by markers operating on 75 megacycles, the same frequency as used by the Z marker. These are known as fan markers(4) and have characteristics different in many respects from the Z markers. The usual airway fan marker is located on

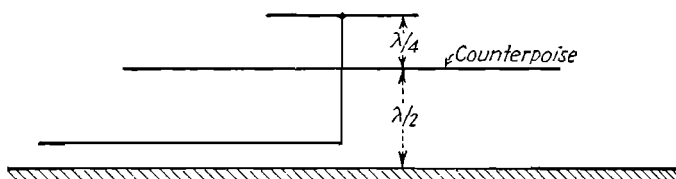

FIG. 99.—Installation of Z-marker antenna with respect to ground.

each leg of a radio range and usually marks where a new range station should be tuned in. It also serves as a definite point over which airplanes may "hold" while waiting for permission to make a landing as well as for traffic reporting points along the airway. These fan-marker signals are in the form of a 3,000-cycle tone and hence actuate the same cockpit light that is actuated by zone markers; however, they are keyed by dashes. These dashes are either single or in groups of two, three, or four. The number of dashes in a group identifies which of the four legs of a range the particular marker is indicating. Errors in aviation have occurred when, because of a strong wind, the pilot intersected one course of a terminal radio range and believed he was on another leg.

Because an airplane might be to the right or left of the on-course of a radio range, it is necessary that the marker for these range legs have a breadth extending at right angles to the major dimension of the range course. The plan pattern of the fan is elliptical and is shown on Fig. 100. The pattern on this

figure is taken with a value of receiver sensitivity approximately the same as is used for receiving the Z marker and at an altitude of 3,000 ft. This pattern varies with altitude as shown in Fig. 101. It can be seen that fan indications for a given receiver sensitivity extend to much higher altitudes than do Z marker

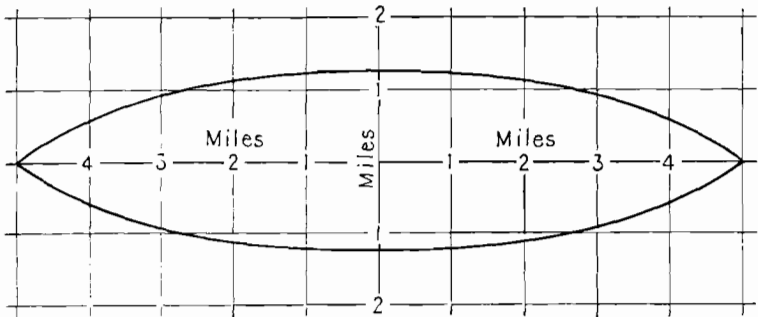

FIG. 100.—Fan pattern of the fan marker.

indications. This is because the airplane must receive the fan indication when it is on the airway and, hence, flying at high altitudes; whereas, the Z is received when the airplane is making an approach to the landing field and has already lost altitude.

Fan-marker Transmitter.—In order that the fan indication might be received over the required area without the necessity

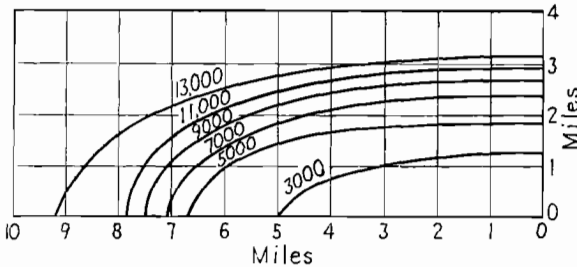

FIG. 101.—Change in fan-marker-plan pattern with altitude. Only one-quarter of each total pattern is shown. The elevations in feet to which the patterns pertain are shown by the numbers on the curves.

for changing the receiver sensitivity, it was essential that the power of its transmitter be greater than that of the Z. Consequently, the transmitter has a rating of 100 watts. It is crystal controlled and operates on 75 megacycles. The very limited area that the radio signals cover effectively prevents the possi-

bility of any interference between either Z and fan markers or the fan markers on the various range legs. The transmitter is modulated by a vacuum-tube oscillator and audio amplifiers. Since the marker receivers are equipped with automatic volume controls acting as a function of the rectified carrier, detrimental effects would be produced if the keying removed the carrier frequency of the markers at keyed intervals. For this reason, keying is accomplished by removing the modulation. The transmitter is a dual unit arranged so that the second transmitter is automatically placed in operation when the rectified output power of the first unit falls to 80 per cent of its normal value.

Fan-marker Antenna.—The antenna forming the fan pattern consists of four half-wave elements, all located coplanar and

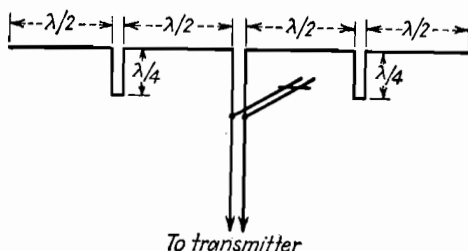

FIG. 102.—Fan-marker antenna array.

with their longest dimension in line. Each element is fed in phase with the element next to it; therefore, a half-wave folded section is employed between the sections in order to correct the phase. An impedance-matching stub is employed at the point where the transmission line from the transmitter connects to the array. This stub in effect tunes the array for purposes of eliminating standing waves on the transmission line. The entire array is located one-quarter wave length above a coarse, galvanized iron screen. This screen in turn is located one-half wave length above the ground. The construction of the array is shown in Fig. 102.

Other Markers.—Besides the two markers already described, two other markers are operated on 75 megacycles. These markers are intended chiefly for use with instrument-landing systems and are located on the route between the airway and the airport. These markers emit 400- and 1,300-cycle notes and

operate separate lights in the cockpit. That is, there are three separate lights, each operated from the same receiver tuned to 75 megacycles. They are distinguished by different colors—white is used for the airway light (fan and Z), purple for the so-called outer marker light (400-cycle), and yellow for the inner light (1,300-cycle). One of these approach markers is located about 5 miles from the airport and the other just at its edge. A simple antenna array consisting of a dipole mounted above a reflecting screen is used with these markers. The power of the transmitter is less than 5 watts.

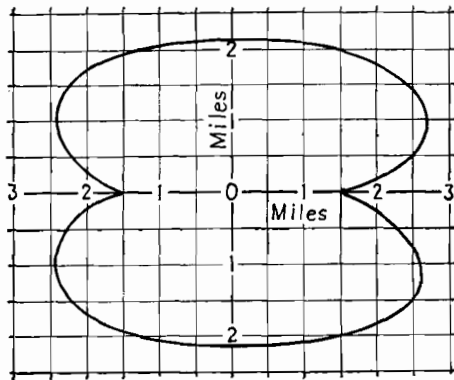

FIG. 103.—Plan pattern of fan marker obtained by flying parallel to the transmitting antenna array.

High-frequency Marker Receiving Antenna.—A criticism of the low-frequency range cone of silence as a marker was the fact that the characteristics of this marker are a function of the coupling between the transmitting and receiving antennas; the same coupling, however, is a factor in the field pattern received from the 75-megacycle markers. Unlike cone reception, any antenna will receive the 75-megacycle indications if it has sufficient effective height and is connected to a receiver with sufficient sensitivity, but the pattern of the area in which these indications will be received (particularly those of the fan) may vary considerably. Figure 103 shows the plan field patterns of the indications obtained when flying parallel to the major axis of a fan-marker antenna array. Referring to Fig. 100, it can be seen that when flying at right angles to the array the pattern was an ellipse having a minor axis of about $2\frac{1}{2}$ miles

and a major axis of 10 miles, but Fig. 103 shows that when flying parallel to the transmitting antenna array the pattern was of the butterfly type with dimensions of approximately 5 by $4\frac{1}{2}$ miles.

If the flying mode remains constant but the receiving antennas are changed, there will be a change in the apparent fan-marker field pattern. Changes in this pattern are shown in Fig. 104. This figure shows that the normal elliptical pattern can be changed from one having a ratio of major to minor axis of $2\frac{1}{2}$ to 9 to one having a ratio of 4 to 6.

The pattern of the Z marker is not so seriously affected by receiving antennas as is the fan marker. Figure 105 shows the

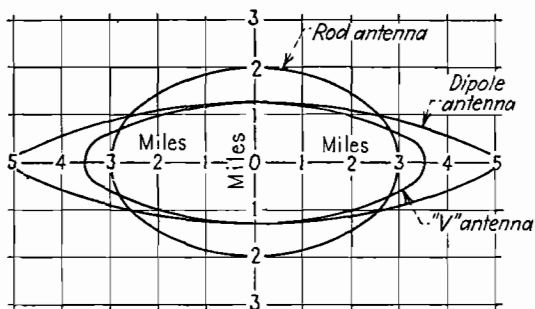

FIG. 104.—Change in fan-marker-plan pattern with various receiving antennas.

change in pattern of the Z marker for three types of antennas. It will be seen that the received Z-marker pattern with a dipole is not very different from that with a vertical rod, although the individual space patterns of these receiving antennas are widely different.

A dipole receiving antenna has a horizontal field pattern (in free space) that consists of two circles tangent to the wire of the dipole. In line with the direction of the wire the pickup is zero, and at right angles to this wire it is maximum. Since the half-wave elements of the fan transmitting antenna are all in phase, the vectorial sum of the voltages at their ends will be zero. It follows that if the receiving dipole is in line with the transmitting dipoles, the pickup should be zero. Due to stray coupling, this pickup is not actually zero but is small and accounts for the narrow axis of the ellipse of the fan-marker pattern. One of the patterns shown in Fig. 104 was obtained with an

inclined vertical rod antenna. Although the directivity of this antenna is unknown, it was probably very small; hence the elliptical pattern having only a small ratio of major to minor axis is probably the true field pattern from the transmitting array. The added directivity of the receiving dipole is required in order to obtain the true fan pattern for which the marker was designed.

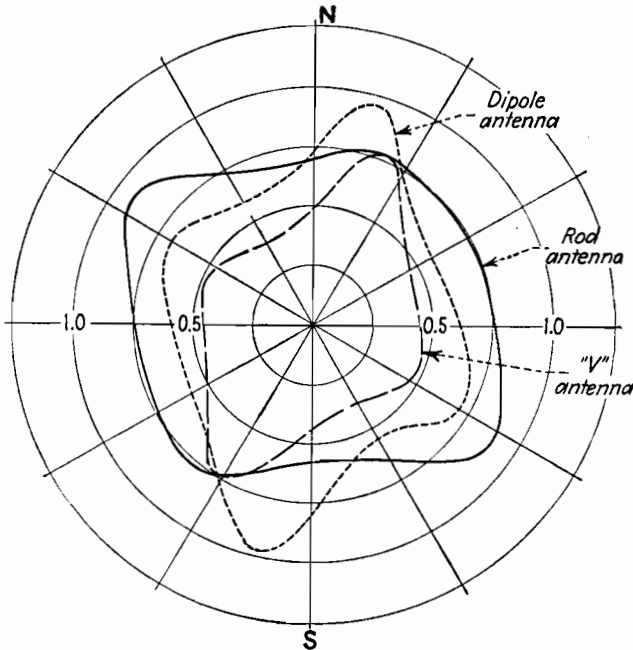

FIG. 105.—Change in Z-marker-plan pattern with various receiving antennas.

The preferred antenna for the reception of markers is of the horizontal half-wave type. This antenna is mounted so that it is under the fuselage, about 5 in. from the surface, and parallel to the major axis of the airplane. The wire forming this antenna may be split in the center and connected to the receiver with either a two-wire or coaxial transmission line. It may be connected to the receiver by means of a single conductor spaced off-center as shown in Fig. 106. Any of these dipole antennas will give approximately the same results.

Because of the construction of the transmitting array, it is seen that the wave transmitted should be essentially horizontal

in its polarization. It has been found, however, that signals emitted from both the *Z* and the fan arrays can be successfully received on a vertical antenna protruding below the fuselage of the airplane.

Marker Receiver.—It has previously been stated that a receiver sensitivity of about $2,500 \mu\text{v}$ is all that is used for the reception of the 75-megacycle markers. Such sensitivity is easily attained even at 75 megacycles, so if this were the only requirement, a comparatively simple receiver could be used. There are other considerations, however, that make a complex receiver desirable. It is very important that no false indications be received on the marker receiver; that is, under no condition

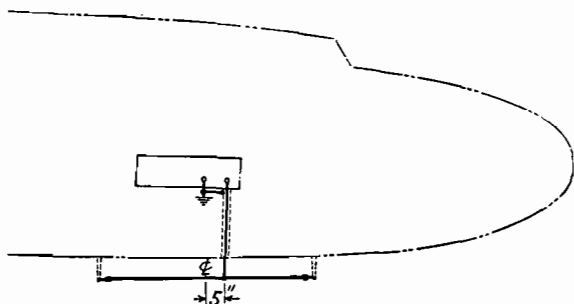

FIG. 106.—Antenna for receiving 75-megacycle marker beacon signals.

except when passing over a marker transmitter must the light in the cockpit become illuminated. It is contemplated that frequency assignments spaced 1 megacycle apart will be made. Some of these assignments will probably be made to very high-powered stations; therefore a high value of selectivity is used in the commercial-transport receivers. With a band width of 60 kc., the attenuation is not over 6 db, but with a band width of 300 kc., the attenuation is not less than 60 db. In order to obtain this selectivity, two stages (three transformers) of intermediate-frequency amplification are used in a superheterodyne receiver. This intermediate frequency is high in order to simplify the problem of image-frequency selectivity. A frequency of 6,325 kc. is used by one manufacturer in order that the image-frequency suppression may be high and the stage gain reasonable. The first tube connected to the receiver input is the first detector; that is, a first stage of radio-frequency

amplification is not employed. In order to obtain the necessary suppression of signals on 6,325 kc. and other adjacent channels, a radio-frequency band-pass filter is used to couple the transmission line from the antenna to the grid of the first tube. The schematic diagram of this filter is shown in Fig. 107. The use of this filter and the choice of intermediate frequency assure a suppression of all spurious responses by at least 60 db.

Since the marker receiver needs to operate on a single carrier frequency only, it is equipped with a crystal-controlled oscillator. The crystal is ground to 7,630.5 kc., which frequency is multiplied by nine for use in the mixer (first detector) tube. This multiplication is accomplished by using one tube as a frequency multiplier in addition to the oscillator. The third harmonic of the crystal oscillator is impressed on the grid of the frequency multiplying

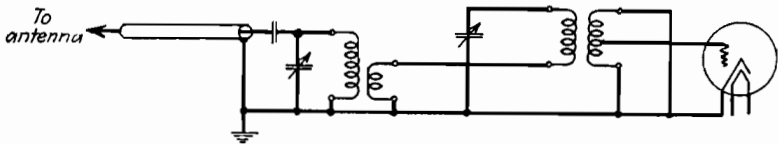

FIG. 107.—Antenna circuit filter for increasing image frequency rejection in 75-megacycle marker receiver.

tube. The plate circuit is tuned to the third harmonic of the frequency impressed on the grid and thus gives the necessary multiplication of nine. The output frequency is impressed on the cathode of the mixer tube.

In order to prevent overloading, an automatic gain control is incorporated in the receiver. This control is of the simple type, but it is sufficient to keep the lamp brilliancy essentially constant for input radio-frequency voltages that vary from 1.5 to 100 μ v.

The audio output from the second detector is amplified and supplied to terminals leading to external headphones and to three band-pass audio filters. These filters are designed to pass frequencies of 3,000, 1,300, and 400 cycles.

Various means have been devised for operating the lights from the audio output of the filters. One of these systems consisted merely of rectifying the audio voltage and applying it to a relay. The contact points of this relay were in series between the signal lamp and the 12-volt airplane power supply. This system has

the advantage in that the lamp, if illuminated, will have a constant intensity that has no bearing on signal strength. On the other hand, if the relay chatters, there will be a false indication.

In order to avoid the use of a relay, one receiver uses alternating-current voltage from a vibrator to illuminate the lamp. This voltage is impressed on the lamp, but in series with this lamp is the secondary of a special transformer. The primary of this transformer is connected in series with a rectifier that supplies rectified tone from the above-mentioned filters. Normally, the secondary of the transformer offers a high impedance to the flow of current from the vibrator, and therefore the lamp cannot become luminescent. However, when the rectified signal passes through the primary of the transformer, it saturates the iron core, and thus the impedance offered by the secondary is greatly reduced and allows current to flow to the lamp. This system has a disadvantage in that the lamps retain a small glow. There is also a half-brilliance point, so the "on-off" position is not so clearly defined as when a relay is used. Some of these objections can be overcome by using a special gas-filled lamp. This lamp has a critical current, below which the lamp will give only a slight glow. The condition can be further improved by using a high-frequency alternating-current power source for the lamps. The reactance of the secondary of the saturating reactor varies with frequency when it is not saturated; however, its impedance when saturated is nearly a constant over a wide frequency range. Using an 800 cycle per second power supply, the action of this saturated reactor closely approximates that of the relay circuit. When a high-frequency alternating-current source is not available, it is necessary to obtain alternating current from a mechanical vibrator. This imposes 90 cycles as the practical upper limit of frequency that may be secured. In event of partial vibrator failure, that is, when the vibrator frequency is lowered, the lamps exhibit an annoying glow, without a 75-megacycle carrier actuating the receiver. This glow continues until the vibrator unit is replaced, so it cannot easily be confused with the indication from a marker carrier; nevertheless this is not a desirable characteristic.

In order to test these marker signals, a push button is usually provided so that the continuity of the lamps may be checked by impressing the airplane's power supply across their terminals.

One of the test methods employed consists of using a circuit tuned to 75 megacycles connected to the receiver input and shock excited with a small door-type buzzer. This system served to test the over-all operation of the receiver. It was not, however, a criterion of receiver sensitivity since it did not operate on a very definite audio frequency. It gave satisfactory results when the receivers were equipped with a single lamp, but when three lamps were employed, the indications were too often false.

The usual receiving-type tubes are used in this equipment. Better performance can be obtained by the use of high-frequency tubes (such as the acorn), but since satisfactory performance

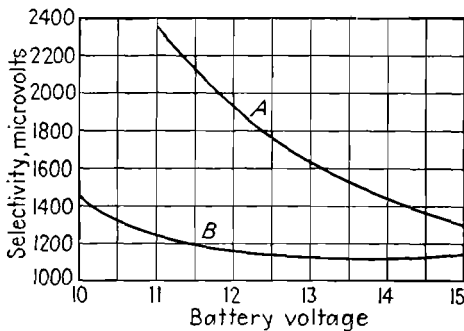

FIG. 108.—Variation in gain of marker receiver with supply voltage: (A) without and (B) with neon lamp and thermistor.

can be obtained with the standard tubes, the greater reliability and lower cost make them more desirable.

Since the gain of this receiver determined the dimensions of the marker patterns, it must remain constant for variations in voltage, humidity, etc. The usual commercial marker receiver does not have peak performance as far as gain constancy is concerned; however, some attempt has been made to secure stability. The screen voltage is stabilized by the use of a neon glow tube. This tube is connected between ground and the screens of the second intermediate frequency amplifier. The screen voltage for this amplifier is obtained by a series resistor from the plate-voltage supply. The use of the neon tube tends to keep the voltage across it constant. Another device used for stabilizing the sensitivity of the receiver is a special form of a resistor known as a "thermistor." This device serves as one

leg of a voltage-controlling audio-circuit potentiometer. This resistor has a very large negative temperature coefficient and tends to keep the current through it constant. The combined effect of using the neon tube and thermistor is shown in Fig. 108. It can be seen that as the power supply varies from 10 to 15 volts the sensitivity varies from 1,450 to 1,350 μv . A similar receiver without stabilization is shown in the same figure to vary from 2,350 to 1,300 μv as the power supply varies from 11 to 15 volts. The receiver for commercial transport use, complete with filters for the three audio frequencies, weighs 20 lb.

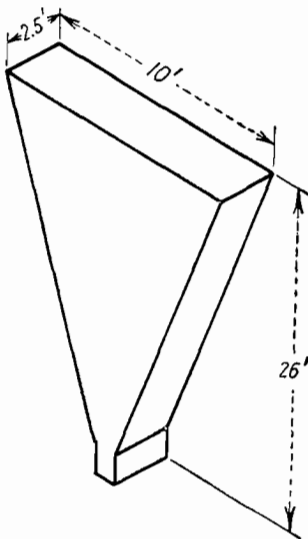

FIG. 109.—Electromagnetic horn similar to that used for microwave marker tests.

Microwave Markers.—Although the ultra-high-frequency marker system described offers many advantages over previous markers, it is true that this is a new facility and many changes may be made in further perfecting it. Several modifications are now being considered. One of these considerations is the use of microwaves at a frequency of about 600 megacycles. It is intended that this frequency be applied to electromagnetic horn radiators (6). These horns are capable of producing a very sharp radio beam. Sharp radio beams can also be produced by the use of directive elements at lower frequencies, so these horns merely replace

the directive array. By using a higher frequency than 75 megacycles, the resulting array for a given directivity of marker pattern is physically smaller. The horn has an added advantage over the marker array previously described in that it has a sinusoidal field distribution that eliminates the presence of spurious lobes. These lobes are smaller field patterns located at the base of the main pattern. When these are received on the airplane's marker equipment, they tend to produce an apparent widening of the over-all pattern. These lobes are particularly noticeable with the fan marker when keying is stopped. At certain altitudes, the light indication will cease for a period and

then continue again; this reaction indicates the break in the over-all pattern caused by the lobes. These lobes are somewhat hidden by the keying.

For purposes of clarification, the presence of these lobes was not indicated on the marker patterns of the figures previously referred to. Other than these advantages, the electromagnetic horn must be considered only as a special form of a directive antenna array which has the advantage (particularly at microwave lengths where measuring technique has not been fully developed) of automatically establishing the correct magnitude and phase of the currents in all the antenna elements.

Tests with such a microwave marker were conducted at the Boston Airport(7), utilizing an electromagnetic horn (which, however, had not been specifically designed for this purpose). The horn was made of plywood and lined with thin copper sheeting. It was 26 ft. long, 10 ft. high, and 2.5 ft. wide (at the mouth). It was excited at a frequency of 710 megacycles by a simple oscillator having a power output of 2 to 3 watts. The signals from this horn were received on a superheterodyne receiver having an intermediate frequency of 10 megacycles. This receiver was connected to a half-wave antenna located below the fuselage of the airplane and spaced from it by a quarter-wave length. The resulting pattern is shown in Fig. 110. It can be seen that this pattern is somewhat better than that of the 75-megacycle marker previously shown.

The tests referred to were not particularly significant as demonstrations of marker improvements, but were really intended as indicators of a new type of marker. By using two of these horns, each modulated by a different audio frequency, it may be possible to develop a marker that has a large pattern allowing it to be easily located and a small centrally located pattern of high accuracy that can be used as a basis for future maneuvers. This central pattern would be obtained by rectifying and comparing the output from the two carriers and, hence, would be independent of receiver sensitivity. Both horns should be excited from the same transmitter so that this smaller pattern would be independent of variations in transmitter output. The outer pattern, since it would be composed of the pattern from both horns, would be subject to the same variations attending the present 75-megacycle markers, but the exact dimensions

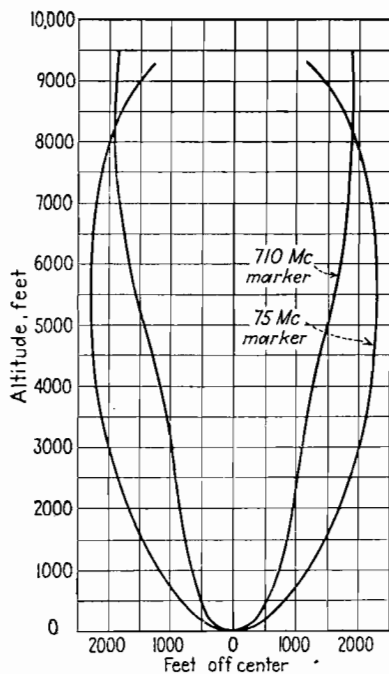

FIG. 110.—Comparison of 75-megacycle marker pattern and pattern obtained during tests with microwave marker.

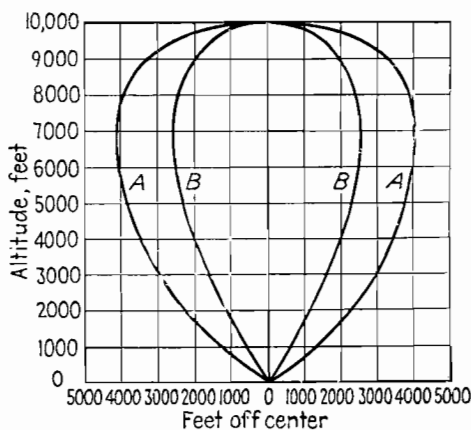

FIG. 111.—Improved 75-megacycle marker pattern (B) compared with standard pattern (A).

of this larger pattern would be unimportant. At present the pilot obtains this information by using the 75-megacycle marker and the cone of the low-frequency range.

Improved Z Marker.—The radio Development Section of the CAA has just announced (8) successful tests of an improved Z marker. This marker, it is understood, utilizes two of the antenna arrays previously described. The pattern obtained compared with the older pattern is shown in Fig. 111. It can be seen that for an indication at a given height the width is approximately five-eighths of the original width.

Problems

1. Develop the calculations for the field pattern of the Z-marker antenna array.
2. Repeat Prob. 1 for the fan-marker antenna array.
3. Some aircraft marker-receiver installations used a "high-low" switch. This was a device whereby two different values of receiver sensitivity could be selected. One of these sensitivities was used at high altitudes and the other to produce a narrow indication at low altitudes. Discuss in detail the pros and cons of incorporating such a switch in an aircraft installation.

Bibliography

1. DIAMOND, H., and G. L. DAVIS: Characteristics of Airplane Antennas for Radio Range Beacon Reception, *Proc. I.R.E.*, February, 1932, p. 346.
2. STUART, D. M.: Report on Cone of Silence Tests at Knoxville, Tenn., *CAA Tech. Development Rept.* 8, April, 1938.
3. JACKSON, W. E., and H. I. METZ: The Development, Adjustment, and Application of the Z Marker, *CAA Tech. Development Rept.* 14, July, 1938.
4. McKEEL, P. D., J. M. LEE, and H. I. METZ: The Development of an Improved Ultra-high Frequency Radio Fan Marker, *CAA Tech. Development Rept.* 17, July, 1938.
5. JACKSON, W. E., P. D. McKEEL, and H. I. METZ: Tests of the First Manufactured Fan Marker, *CAA Tech. Development Rept.* 15, July, 1938.
6. BARROWS, W. L., and F. D. LEWIS: The Sectorial Horn, *Proc. I.R.E.*, January, 1939, p. 41.
7. MOSELY, F. L.: Report of the CAA Marker Demonstration, pp. 5-13, Radio Technical Committee for Aeronautics, Subcommittee 13, Jan. 13, 1941.
8. MOSELY, F. L.: Markers, annex 7, Radio Technical Committee for Aeronautics, Subcommittee 13, Jan. 13, 1941.

CHAPTER VI

INSTRUMENT LANDING

The airplane has a problem that is not encountered by the usual land vehicle. Although it may have successfully avigated two dimensions, it must still travel a third—downward—in order to complete its journey. All the devices previously discussed were for enabling safe travel in two dimensions, but the problem of traversing the third involves a development different from any of these. The farsighted scientists of the Bureau of Standards foresaw this problem and developed a system for its alleviation during the years 1928 to 1930. It is true that the instrumentation employed was rather crude compared with the radio apparatus of today; nevertheless this development incorporated all the elements of a true *instrument-landing* system. Today (some 11 years after the announcement of their development by the Bureau) there are installed five privately owned systems used only for training, three Civil Aeronautics systems, and approximately six experimental systems of various kinds. In addition to these installations, the government has ordered 16 sets of equipment for use on the civil airways. Each system proposed was thoroughly criticized; then steps were taken to develop improvements. This is not the procedure that was employed with other radio aids to avigation, which were accepted after a reasonable amount of development, installed, and *then* corrected.

Although many successful demonstrations have been made with a number of systems, no system has been completely installed throughout the country. The reason for the delay in adopting a standard system is not known, but perhaps it was the fear of accident with an imperfect system; for, without doubt, landing under conditions of low visibility is the most hazardous maneuver that an aircraft executes. Whatever system is adopted, past performance would indicate that it will have failings, and the system will approach perfection only after thou-

sands of landings have been made by hundreds of pilots and numerous corrections are incorporated in the equipment.

With such a background it can be seen that a chapter thoroughly covering instrument landing can be more a history than a technical treatise. A book can be written covering the various systems; however, it is not intended that this be done. The original system of the Bureau of Standards will be covered, with an explanation of the underlying principles of any instrument-landing system, followed by a discussion of those systems which seem to incorporate some original principle. No attempt will be made to describe in detail those systems which can more accurately be termed "low approach" rather than "true landing," because fundamentally they supply guidance only in the horizontal plane and designate the point where the engines should be throttled back for landing.

Principles of All Instrument-landing Systems.—In order to effect a landing it is necessary for the pilot of an airplane to know accurately his position in space. Since this involves familiarity with three dimensions, the necessity for an instrument-landing system having three elements is evident. The previous chapters showed that a radio range can be used to determine the position of an object along a line. The line may be considered as one axis in the Cartesian coordinates. If markers are added, the value of the second coordinate is given and the location of a point on a plane is indicated. A third element, therefore, is required to determine the location of the airplane. This element is known as a glide path.

Bureau of Standards Glide Path.—As the distance between a transmitting antenna and a receiver is increased, the field strength of the station measured at the receiver decreases. If there is no attenuation caused by ground, this field strength can be written as

$$E_f = \frac{K}{d} \quad (123)$$

In this expression, K is a constant determined by the power of the transmitter and its antenna system. This fact is well known.

Depending on the antenna used, however, there is also for any constant horizontal distance from the transmitting antenna a variation of field strength with vertical distance. The energy

from the antenna strikes the ground at various points and is reflected to where it adds to or subtracts from the direct energy from the antenna. The resulting pattern in the vertical plane is, then, a function of the antenna structure, its height above ground, and the characteristics of the ground. Such a vertical space pattern is shown in Fig. 112. This figure shows the space pattern of an antenna in the vertical plane. The phenomena depicted by this figure are quite similar to those which have been discussed in this book in connection with many antennas but apply to the vertical rather than the horizontal plane. This pattern is not to be confused with those vertical patterns shown

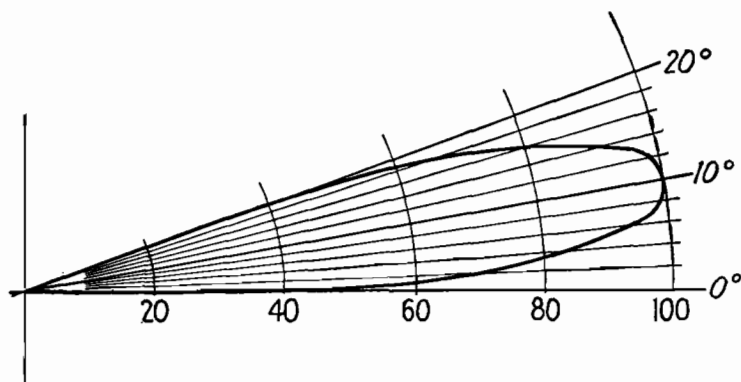

FIG. 112.—Vertical field pattern of an antenna.

in the chapter on Markers. The marker vertical patterns referred to showed the area where a signal was set off in the receiver; whereas, the distance from the origin to any point on the pattern of Fig. 112 represents proportional field strength. This proportion is related to any arbitrary value. Thus, Fig. 112 is in percentage, and if the value at 10 deg. is 100 per cent, it is only 80 per cent of the maximum at 3 deg. Again, it is necessary to warn against confusing this vertical pattern with the vertical pattern of the landing path that will now be discussed.

Referring to Eq. (123), if at distance d_1 the field strength equals 1, then at distance $d_2 = 1.25d_1$ the field strength will equal only 0.8. Suppose, however, that the reading for distance d_1 had been taken at a point elevated from the ground by a height h_1 such that $h_1/d_1 = \tan \gamma_1 = \tan 1^\circ = 0.0175$, then, referring to Fig. 112, it can be seen that the loss of field strength

occasioned by the greater separation from the transmitting source can be retrieved by climbing to a higher altitude such that $h_2/d_2 = \tan \gamma_2 = \tan 5^\circ = 0.0875$. To explain further this principle (attributed to F. W. Dunmore of the Bureau of Standards), numerical values can be assigned to d_1 . If d_1 equals 1,000 ft., then the values in Table II can be calculated.

TABLE II

d	γ	h
1,665	10	293.5
1,250	5	109.3
1,000	1	17.5

The points of Table II are plotted in Fig. 113. If a means for indicating field strength is installed in the airplane and its

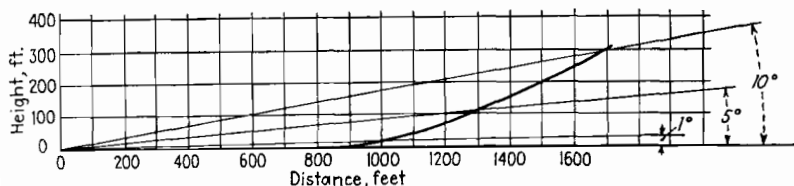

FIG. 113.—Constant-potential glide path derived from the field pattern of Fig. 112.

altitude adjusted as the radio station is approached so that the same value of field strength is at all times read on the field-strength meter, the airplane must necessarily follow a path similar to that obtained by connecting the points of Fig. 113. That is, as the airplane flies toward the transmitter, altitude must be lost, and this is of course the landing procedure. Any value of field strength may be selected, and each value will describe a separate path, all similar in shape, but having different slopes. Further elaboration of this statement will be made later.

The Bureau of Standards glide path, therefore, is an isopotential path. That is, it is the locus in space of an infinite series of points where the glide-path transmitter produces signals of equal field strengths. By selecting various numerical values of field strengths to be indicated on an instrument, an infinite

number of paths are available with the isopotential glide path. The general shape of each is the same. This is illustrated in Fig. 114. In this figure there are plotted data actually secured from a glide-path transmitter. Four different glide paths are shown, each for a different field-strength value. Since these

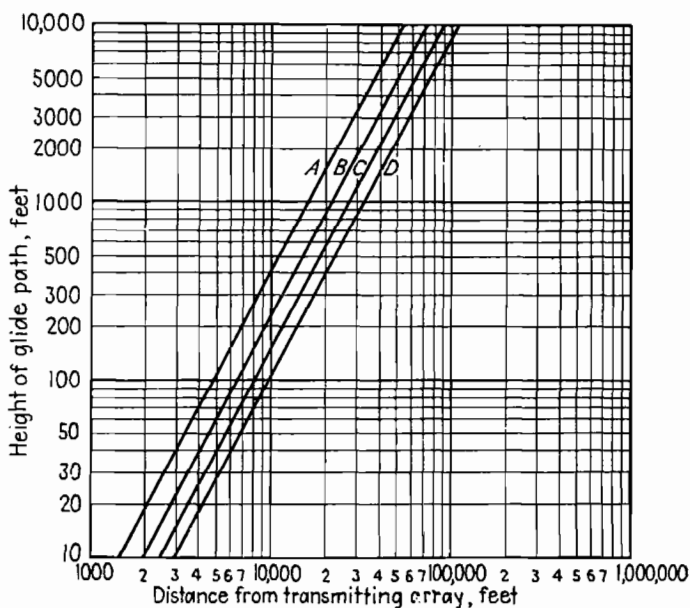

Fig. 114.—Four isopotential glide paths obtained by varying the transmitter power or the receiver sensitivity. Since the paths are represented by parallel lines on log-log paper, the paths must have similar shapes.

data appear as straight lines on log-log paper, it is immediately evident that each path follows the equation

$$h = KD^n \quad (124)$$

where h = height from the ground to the receiving antenna
 D = horizontal distance from the transmitter to a point
 on the ground directly below the receiving antenna
 K = constant
 n = coefficient (function of selected field strength)

It is further evident that since all lines are parallel the slope is the same; therefore, the coefficient n of Eq. (124) is the same

for all paths. This coefficient is 2 for the curves shown, and if it is substituted for n in Eq. (124), the following results:

$$h = KD^2 \quad (124a)$$

The variation in the selection of the different paths changes only the constant K ; hence each path has the same general shape.

In a practical landing it is desired that the airplane landing gear make contact with the ground at a given distance from the transmitting array in order that sufficient length of runway will be available for decelerating the airplane without damage. Further, the height of the receiving antenna above the fuselage of the airplane (and hence its height at point of contact) is fixed by aerodynamic considerations. With these two factors established, the path to be followed is fixed.

The equation(2) for this isopotential glide path has been developed for the general case and is given as

$$\left(\frac{r}{r_0}\right)^2 = \frac{1 + A^2 + 2A \cos\left(\frac{4\pi hy}{\lambda r}\right)}{1 + A^2 + 2A \cos\left(\frac{4\pi hy_0}{\lambda r_0}\right)} \quad (125)$$

where r = distance from the transmitting antenna to any point on the glide path

r_0 = distance from the transmitting antenna to the point of contact

y_0 = height of the landing path at the point of contact

h = height aboveground of the transmitting antenna array

y = height of any point on the glide path

A = reflection coefficient for the ray reaching the point (r, y) by reflection from the ground surface in front of the antenna

This reflection coefficient is given by

$$A = \frac{\sin \theta - \sqrt{K' - \cos^2 \theta}}{\sin \theta + \sqrt{K' - \cos^2 \theta}} \quad (126)$$

where $\theta = \frac{\text{arc sin } y}{r}$

K' = effective dielectric constant of the reflecting ground and is given by

$$K' = K - \frac{2j\sigma c^2}{f}$$

where K = real dielectric constant

σ = conductivity of the ground

c = velocity of light

f = transmitter frequency

The Bureau of Standards System.—The glide path for this system has already been described. The transmitter used for producing it consisted of a single 500-watt oscillator tube operating on a frequency of 93.7 megacycles.

The energy from it was fed to a directive array that concentrated the radiation in a horizontal pattern covering a horizontal angle of about 40 deg. This antenna array was located at the end of the runway. On the airplane a simple receiver was connected to a horizontal dipole and its rectified output was measured on a meter. This meter was mounted so that the pointer moved vertically, thus the psychological correlation between the movement of the pointer and the vertical position of the airplane was improved.

A small radio range of the visual type was located at the end of the airport runway in such a manner that its course was directly down the middle of the runway. This radio range was, and is still, called a "localizer" and will be so referred to in later discussions. The receiver on the aircraft operated a vibrating-reed indicator. The third element consisted of a low-power transmitter operating on the same carrier frequency used by the localizer. This transmitter served as a marker to indicate the edge of the airport. Indications received from it were aural. The localizer was operated on a low frequency in the band employed by the airway radio-range system. It is apparent that the only radio equipment required in addition to the regular range receiver in order to make instrument landings with this system was the glide-path receiver.

An important instrument was later designed and has been used in nearly all instrument-landing systems developed subsequent to that by the Bureau of Standards. The localizer transmitter modulation was changed to 60 and 500 cycles. In the receiver, these frequencies were separated by means of suitable wave filters, and the output from these channels was rectified

and applied differently to a zero-center meter. This meter indicated the relative intensity of the 60- and 500-cycle signals, or the position of the airplane to the right or left of the middle of the runway. The next step consisted in mounting this meter so that it had a scale common to the glide-path meter. If the needles of the two meters crossed in the center of the scale, the airplane was on its glide path and in line with the middle of the runway. This meter is shown in Fig. 115. Because it was necessary for the localizer receiver to operate properly when

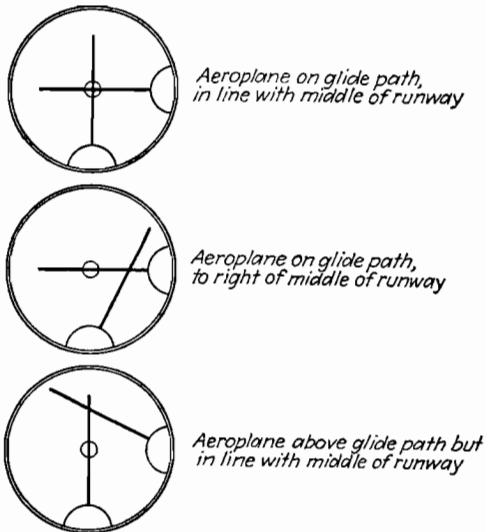

FIG. 115.—The operation of the Bureau of Standards instrument-landing indicator.

very close to or very far from the radio station, that is, over a large range of signal strengths, an automatic gain control was incorporated in it. A meter reading the amount of this automatic-gain-control current was added and calibrated in approximate miles. This meter was useful in indicating whether the airplane was approaching or had already passed the station. In order that the gain of the glide-path receiver remain constant, it was made with only a few elements. Only two tubes were used. The first of these was a radio-frequency detector and the second an audio-frequency amplifier. The sensitivity of this receiver was necessarily low, and this was compensated for by making the field strength high.

The statement was previously made that the instrumentation used with this system was comparatively crude; consequently, there was much instability in its operation. However, the imperfect state of the radio art existing in 1928 should be kept in mind. It should also be remembered that this system was designed for use in small, single-engined airplanes where ounces of weight were important and for an industry that still considered radio more a plaything than a means for practical day-in and day-out flight operations. The instrument-landing system of the Bureau of Standards is to be remembered as the first system that defined all the essential elements, originated the isopotential glide path, and incorporated an instrument that coordinated indications with respect to two dimensions.

United-Bendix System.—Sometime during 1933 or 1934, work was stopped on the development of instrument landing by the Bureau of Standards. The Bureau of Air Commerce was established and development of airway radio aids was taken over by the Airways Division of this Bureau. At this time the Bureau of Standards had installed systems at College Park, Md.; Newark, N.J.; and Oakland, Calif.

A number of questions remained unanswered with the cessation of the Bureau of Standards work. All the flights on this system had been made with small, low-speed, single-motored airplanes, and their use for commercial service was also terminated in 1933 or 1934. In 1933 there came into use the high-speed, low-wing, twin-engine airplane used by all commercial airlines in this country. Statements were made that this airplane could not be flown to the ground on the rigidly prescribed beam of the radio glide path.

It was recognized that the instrumentation had to be improved before the system could be considered thoroughly practical. The localizer had all the weaknesses that have previously been discussed for the vibrating-reed visual-range system. In 1934, United Air Lines entered into an agreement with the Eclipse Aviation Corporation (a branch of Bendix Aviation Corporation) for the joint development of an instrument-landing system. This agreement later was transferred to the Bendix Radio Corporation when that company was formed. At a still later date, the agreement was extended to include Transcontinental and Western Air Express. By agreement with the Port of Oak-

land, Calif., the instrument-landing system which the Bureau of Standards had installed there was taken over and became the basis for further development.

The first steps were taken for the purpose of determining whether or not the radio glide path could be used by large airplanes and by those of the modern type. The tests resulted in an affirmative answer, and a technique employing the automatic pilot to assist in making landings was developed.

The defects of the localizer system were immediately apparent. The localizer originally installed had operated on a frequency

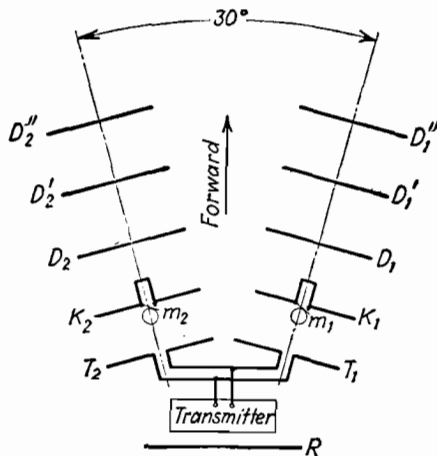

FIG. 116.—The Bendix-United Air Lines instrument-landing transmitting-antenna array.

of 278 kc., and when the range course crossed a power line at the end of the landing field, it bent abruptly toward the Oakland Hills. In an attempt to solve this problem, ultra-high frequencies were tried. The frequency used was the same as had been used for the glide path, that is, 93 megacycles. A localizer using this frequency was found to be entirely satisfactory. After leaving the transmitter, the localizer course continued in a straight line, unaffected in so far as its directional characteristics are concerned.

Having seen the weakness of the visual localizer using separate amplifiers, but desiring to retain visual indications, an ingenious method was designed utilizing only one radio-frequency channel. This localizer is shown in Fig. 116.

United-Bendix Transmitting Antenna.—Figure 116 is the plan view of an antenna system commonly referred to as a “Yagi” array. All the elements of this array are excited because they are in a radio-frequency field. Excitation is by this means alone as there are no metallic electrical connections to these elements; hence it is said that they are “parasitically” excited. Two antennas T_1 and T_2 are connected in parallel and to a transmitter. They are tuned by a single condenser (not shown in Fig. 116); therefore any change in the output of the transmitter affects equally the output of both antenna arrays. The transmitter is not modulated. To the rear of the antennas connected to the transmitter is an antenna that serves as a reflector for both arrays. It is designated as R in Fig. 116. This antenna has a length greater than the transmitting antennas. In front of the transmitting antennas are the keying directors K_1 and K_2 . These are shorter than the transmitting antennas, but at their centers is connected a length of line making the total length of the antenna, plus line, greater than the length of the transmitting antenna. Also connected across the centers of the keying directors are motor-operated switches. When these switches are closed, the lines across them are shorted out. This makes the length of the directors shorter than the transmitting antennas, and the energy in the forward direction is increased. When these switches are opened, the length of the directors is greater than that of the transmitting antennas; hence they act as reflectors and reflect energy to the rear in the direction of the reflector R . However, R is reflecting the energy forward; therefore, when the motor switches are open, there is effectively no radiation. Motors M_1 and M_2 are synchronous and run at the same speed, but their cams have a different number of lobes. One cam has seven and the other has nine lobes. The cams have speeds (by virtue of gearing) of 10 r.p.s.; hence the two arrays generate field patterns having square-wave keying of 70 and 90 cycles per second. The antennas marked with D 's in Fig. 116 are directors that further increase the forward radiation. The total power gain of these arrays is about 13. The resulting field pattern is essentially as shown in Fig. 117.

It will be noticed that all antenna elements shown in Fig. 116 are in the same horizontal plane; hence the radiation emitted by this antenna system is essentially horizontally polarized.

The most satisfactory type of polarization was the subject of research during the development of this system. It was found that the radiation from horizontal antennas was much less affected by varying ground conditions caused by precipitation than was the radiation from vertical elements. It was further found that for the horizontally polarized waves, snow or rain on the ground caused the glide path to rise slightly, whereas with vertically polarized waves, the glide path fell and created a hazardous condition.

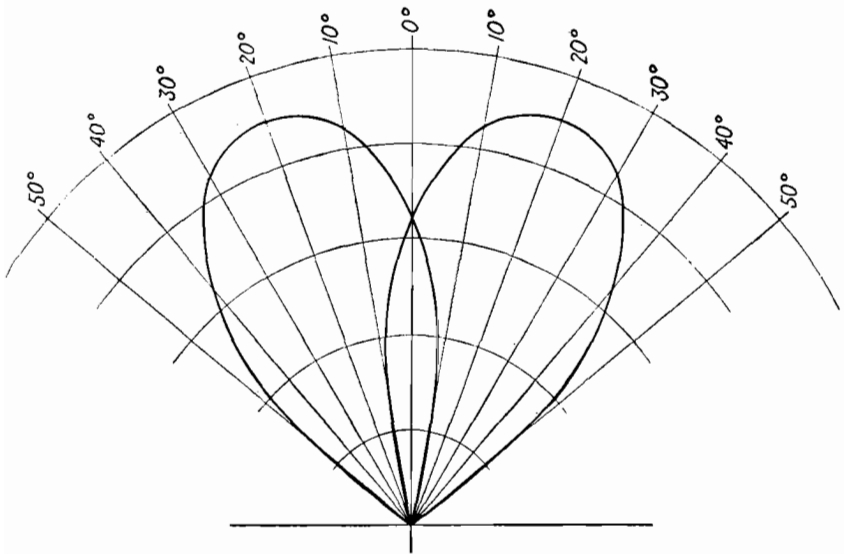

FIG. 117.—Horizontal-plane field pattern obtained with the transmitting array of Fig. 116.

After having decided on the localizer, attention was turned to the glide path. It was decided that the isopotential glide path developed by the Bureau of Standards would be satisfactory. During the course of this work, however, it was realized that the radiation from either antenna array constituted a glide path in all respects similar to the Bureau of Standards path. If, however, the airplane moved to the right or left of the direct line of the array, there was a change in the signal strength (see Fig. 117); hence the glide path would undergo an apparent change. In order to counteract this phenomenon, the signals from both arrays were added and used. This made necessary

only a single receiver for receiving both the glide path and localizer indications. The transmitting array is located directly in line with the middle of the runway and at some distance from its end. Extensive work on markers was not done by the group developing this system, and so the results along this line of endeavor are not clearly definable. Government agencies were working on markers, and it was anticipated that these would be used.

The Bendix Transmitter.—By the time that this system was ready for commercial production, much progress had been made in ultra-high-frequency instrumentation; therefore the transmitter was crystal controlled. A crystal having a fundamental frequency of 3,912.5 kc. was used. The crystal oscillator was followed by three stages of frequency multiplication. The first stage quadrupled, the next doubled, and the last tripled the frequency, the result making a total multiplication of 24 and giving a resultant frequency of 93.9 megacycles. The energy from the doubler was used to excite a power amplifier, and the resultant power output was 300 watts. Each stage after the oscillator used two tubes. The grids of the stages having even-numbered multiplication were connected in push-pull and the plates in parallel. The grids and plates of the tripler stage were connected in push-pull, and this connection was also used in the power-output stage.

Thermostatically controlled fans were used to keep the transmitter at a satisfactory temperature level, and voltage regulators were employed to assure constant output under conditions of varying line voltage. A monitor located at the transmitter control point was used. This monitor merely indicated the relative values of the currents in the two transmitting antennas.

The Bendix Receiver.—The receiver used with this system is shown in simplified schematic form in Fig. 118. In Fig. 118 two tubes V_1 and V_2 connected with their grids in push-pull and their plates in parallel serve as radio-frequency grid-leak detectors. This detector output follows a square law. The plates connected in parallel serve to cancel the radio frequency, and only audio appears at these plates. Following these tubes, all further amplification is of the audio frequencies. The first audio-frequency amplifier is the tube V_3 . From the description of the modulator it can be seen that the resulting audio wave

forms would be square; hence they would consist of two fundamental frequencies with an infinite number of higher order harmonics. For the purpose of removing these harmonics, a low-pass filter is used following the first audio amplifier tube. Following this filter the audio frequencies are applied to two separate channels. One channel utilizes a single stage of amplification (V_4), then the resultant energy is rectified by two diode rectifiers V_9 and V_{10} . The rectified energy from tube V_9 contains the resultant of the radio-frequency fields from both the

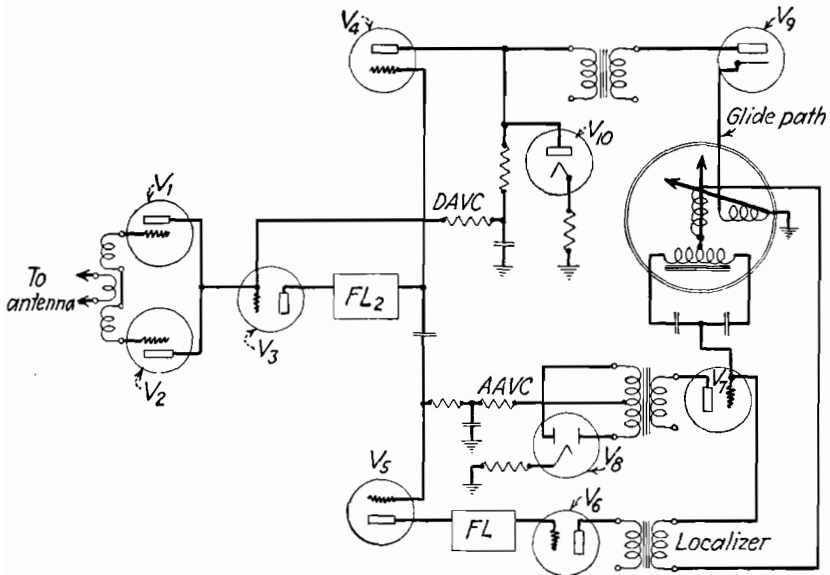

FIG. 118.—Simplified schematic of the Bendix-United instrument-landing receiver.

70- and 90-cycle lobes and is applied to the instrument to furnish glide-path indication.

The cathode of rectifier V_{10} is biased with a comparatively high potential, so it does not rectify unless the voltage applied to it has reached an excessive value. When it rectifies, its output voltage is applied to the grid of amplifier V_3 to furnish automatic volume control. This automatic volume control, then, acts only as a means for preventing the overload of the receiver and becomes effective only after the glide path pointer has reached full scale. The second of the two parallel channels employs two stages of audio-frequency amplification with an

additional low-pass audio filter between them. The output of this second stage (V_6) is applied to the localizer-indicating instrument and to another audio amplifier V_7 . The indicating instrument is an unusual device. It is of the alternating-current dynamometer type, but further it is a differential instrument with two coils serving to move the pointer to the right and left. These coils are so selected that, together with the condensers connected in series with them, they form selective circuits. One coil is sensitive only to 70 cycles per second energy, and the second is sensitive only to 90. If the amount of the energy at these two frequencies is equal, the needle will not deflect, but it will deflect to the right or left if either of the two frequency energies exceeds the other. The audio amplifier V_7 is followed by a full-wave rectifier V_8 . The output from this rectifier is applied back to control the gain of the tube V_5 . This amplified automatic control voltage serves to keep the output of the tube V_6 always constant. The use of automatic gain control maintains the sensitivity of the right-left indication constant.

In the same instrument used to indicate glide path is a direct-current microammeter which indicates the amount of energy from rectifier V_8 and, hence, furnishes the glide-path indication. The pointers of the instrument are crossed on a common scale; that is, the indication follows that developed by the Bureau of Standards.

The screen voltages are controlled with a voltage regulator to ensure stability of sensitivity with change in power-supply voltage. Since audio-frequency amplifiers can be made so that their gain is very stable, the resulting receiver possessed great stability. The total weight of this receiver is 20 lb.

The Bendix Antenna for Receiving.—It is important that the output of the receiver remain constant as the heading of the airplane is changed, otherwise there will be an error in both the localizer and glide-path indications. An Alford loop, previously described, would be satisfactory for this purpose, but at the time that this system was developed the loop had not yet been invented (or if it was in existence it was not generally known), so an antenna having an approximate circular field pattern was designed. This antenna was also in the form of a loop with a periphery somewhat less than one-half wave length. One of the ends of this loop was open, and the other was terminated in a

short transmission line that fitted with a short-circuiting bar which was used for tuning. From this transmission line a coaxial cable connected to the receiver. This antenna is shown in Fig. 119. It is mounted above the fuselage and spaced from it by a distance of 18 to 26 in.

Shortcomings of the United-Bendix System.—Up to the present time there have probably been more landings made in this country on this system than on any other. At least 3,500 hooded landings have been successfully executed. Five such systems are owned by United Air Lines and are used for pilot training.

Other than this, there has been no further adoption of the system in this country, probably because of the shape of the glide path. It has been argued that the glide path has a "natural" shape, that is, as the airplane approaches the ground, it levels off preparatory to touching its wheels. This is probably true; however, it can be seen from Fig. 113 that the glide path has a long low section near the terminal. A portion of this section is necessary for a commercial landing (where comfort to passengers and minimum risk are important considerations). Furthermore, it is important that the portion of the glide path beyond the airport boundary be quite steep so that near-by objects can be cleared by a large margin. There is also another school of thought that argues for a straight-line glide path so that the speed of descent, and hence the throttle setting, is constant during the entire landing. The United-Bendix glide path is rather inflexible. It is not possible to increase the steepness of the glide path without also bringing the point of contact (where the wheels of the airplane first touch the ground) quite close to the transmitting array and hence too close to the end of the runway. The only method by which this situation can be remedied is to increase the height of the antenna on the airplane. This principle may be illustrated by referring to Fig. 114. The field strength of the transmitter may be changed by any desired amount, but this only adds more lines parallel to those of Fig. 114. If it is decided that the point of contact must be 2,100 ft. from the transmitting array and the maximum receiving antenna

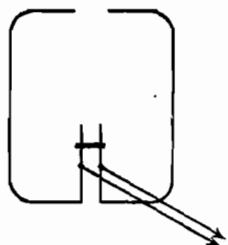

FIG. 119.—Bendix-United Air Lines instrument-landing receiving antenna.

height that can be tolerated with the airplane on the ground is 20 ft., the altitude of the glide path at a point 50,000 ft. from the transmitting array is fixed at 9,000 ft. The CAA believed that a path with a controllable shape was necessary in order that it might be installed at all the major airports of the United States, and a contract was awarded to the International Telephone Development Company for such a system.

Controlling the Shape of the Isopotential Glide Path.—In the previous discussion of methods for producing a glide path, the transmitter was always located near the end of the runway. In Fig. 120 a transmitting antenna is located at *A*, some distance

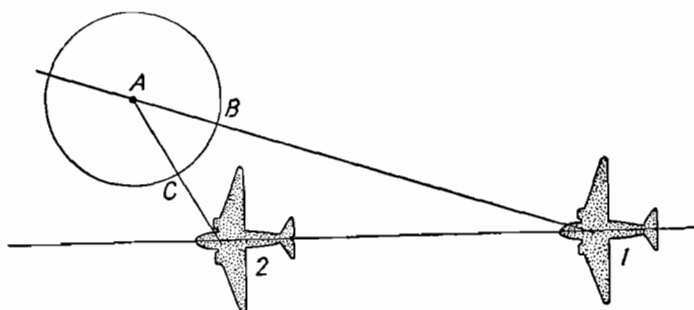

FIG. 120.—The glide path transmitting-antenna array located at point *A* is nondirectional and therefore the glide path will be essentially the same as if the array were located at the end of the runway.

from the runway on which the airplane is to land. The antenna is nondirectional, hence the plan field pattern is a circle. When the airplane is in position 1, it receives a signal proportional to the distance *AB*, modified by the vertical field-strength characteristics as shown in Fig. 113.

If the receiving antenna on the airplane is nondirectional, and if the distance from the transmitting antenna to the airplane is large as compared with that from the runway, the signal received will be the same as if this transmitting antenna had been located at the end and in line with the runway. Suppose that a reflecting antenna is placed in front of the transmitting antenna in such a position that it is in direct line from the transmitting antenna to position 2 of the airplane. This will cause the weakening of the field-strength pattern in the direction of position 2 as shown in Fig. 121. In order that the field-strength meter in the airplane may indicate the same value as before the reflector

was added, it is necessary for the airplane to climb to a higher altitude. If the airplane is just approaching position 2, it will

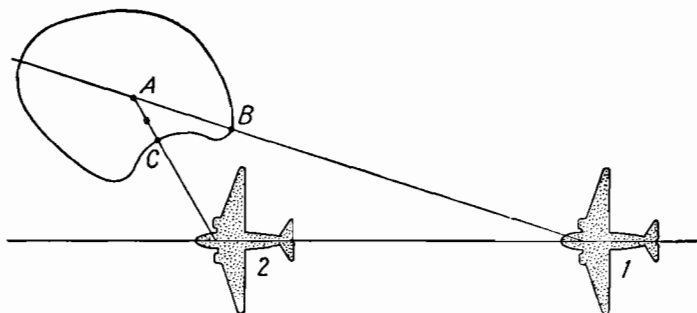

FIG. 121.—If the horizontal plane pattern of the transmitting array is distorted by a reflector so that the field at position 2 is reduced but that at position 1 is unchanged, the glide path at position 2 will be elevated.

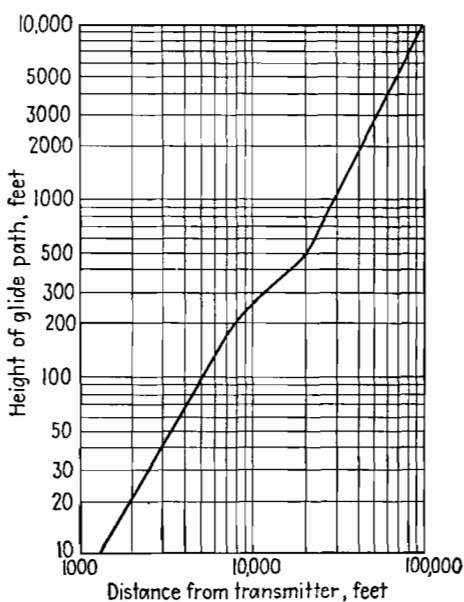

FIG. 122.—Glide path that may be produced by the field pattern shown in Fig. 121.

receive the proper field-strength signal at a higher altitude than previous to the time that the signal strength was weakened by the addition of the reflector. When the airplane is at position

1, it is at an angle with the transmitting antenna such that the field strength is unaffected by the reflector. That is, the same field strength as before is received, so the airplane is on the same glide path that it previously followed. The glide path, then, has been greatly modified without changing the relative vertical radiation characteristics of the antenna. This is illustrated in Fig. 122. This figure contains two of the same curves that were shown in Fig. 114. The shape of these curves has not been changed. The airplane merely follows one curve to the transition point, then flies the second curve. The same effects could be accomplished by changing the sensitivity control of the glide-path receiver, and this was actually done on a European system. It can be seen, however, that by using a number of reflectors having various efficiencies and placing them in line with different points along the airplane's gliding path this path can be shaped to any desired pattern.

The Civil Aeronautics-International Telephone Glide Path.----

Figure 122 is not to be taken as the glide path of any particular system, since it is intended merely to illustrate the method developed for controlling the shape of the glide path. The first glide path developed by the CAA-I.T.D. system at Indianapolis was a straight line(3). After flights by various pilots, however, it was decided that this path was too steep and would cause alarm and discomfort to passengers. The path finally decided upon was one that was essentially straight from a point having an altitude of 1,500 ft. and located 5 miles from the boundary of the airport. The path became parabolic at the field boundary and intersected the runway surface at approximately 1 deg. The path passed over a point 2 miles from the airport at an elevation between 500 and 700 ft.

The antenna array used for producing this path consisted of a number of Alford loops located in front of a reflecting screen. The amount and phase of the current in each element of this array are individually controlled to produce the path described above. The details of this array are not available for publication.

Glide-path Transmitter.—The glide-path transmitter is located 1,350 ft. from the middle of the runway and 1,050 ft. from its end. It is crystal controlled and has a frequency of 93.9 megacycles. This frequency is generated by a 3,912.5-ke. crystal. The transmitter has an output of 300 watts and is modulated

continuously by a frequency of 60 cycles. A regulator is used to keep the power-supply voltage constant within 1 per cent for normal fluctuations of the supply mains. A constant field strength is as important with this glide path as with those of the systems previously described.

Glide-path Receiver.—A receiver having as its sole purpose the reception of the glide-path signal is used with this system. It is a crystal-controlled superheterodyne unit capable of receiving on any one of three frequencies. These frequencies are 93.5, 93.9, and 94.3 megacycles and are selected by electrical switching.

An intermediate frequency of 10 megacycles is used. The selectivity is specified such that the gain of the receiver shall be equal within 6 db (compared with the gain at maximum response) for a band width of 60 kc., and the attenuation for a band width of 240 kc. is not less than 60 db. In addition, the selectivity of the receiver is specified such that the gain will be equal within $\frac{1}{2}$ db over the band 93.5 to 94.3 megacycles. The over-all selectivity is further increased by the use of a 60-cycle audio filter. This filter has the following characteristic:

Frequency in Cycles	Maximum Output in Decibels Down from 60-cycle Value
50	6
75	6
35	25
100	25

The sensitivity of the receiver is such that when measured with an artificial antenna of 175 ohms (resistive) the output is 150 microamp. of rectified audio current through 2,000 ohms when the input is a 750- μ v carrier modulated 30 per cent with a 60-cycle-per-second audio note. Under these conditions the noise output (measured before the filter with the modulation removed from the carrier) is 40 db less than the normal audio output.

The outstanding feature of this receiver is its stability. Any change in gain necessarily changes the apparent location of the true glide path, so special efforts must be made to keep the gain of the superheterodyne receiver constant in spite of its several cascade stages. The stability of this receiver is such that the gain remains constant within plus or minus 1 db when subjected to any of the following combinations of conditions: (1) Temperature -35 to $+55^{\circ}\text{C}$. with humidity 15 to 60 per cent, or -35 to

+40 deg. with humidity 15 to 95 per cent. Battery voltage 10 to 15 volts. Air pressure 8.52 to 31 in. of mercury. (2) The replacement of tubes, crystals, or power supplies. (3) Reduction of excitation to the converter tube to one quarter of its normal value. Further, the gain does not change more than $\frac{1}{2}$ db when the modulation frequency varies plus or minus 1 cycle, and the gain remains constant to within $\frac{1}{4}$ db when the supply voltage and temperature are maintained constant to within 5 per cent.

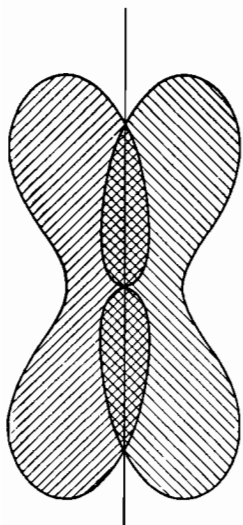

FIG. 123.—Horizontal-plane field pattern of the CAA-I.T.D. instrument-landing localizer.

The receiver input is balanced and has an electrostatic shield. It is designed to match a 175-ohm transmission line which is connected to an Alford receiving loop described in Chap. III.

The rectified output of this receiver is connected to a cross-pointer instrument and serves to move the needle in a vertical direction in a manner similar to that for the glide-path instrument of the systems previously described.

The weight of this receiver is 16 lb.

The CAA-I.T.D. Localizer.—The localizer used with this system is bidirectional as shown in Fig. 123. The two lobes are modulated with 150 and 90 cycles, respectively. The method for producing this pattern is novel. The antenna array consists of three Alford loops (of the transmitting type described under Ultra-high-frequency Ranges) located in the apex of the roof of the wooden transmitter house. Complete details of the method for producing this localizer pattern have not yet been published, so the following description is given to illustrate the principles used and must not be assumed as accurate in detail. Two radio-frequency bridges(4) are used. The schematic diagram for such a bridge is shown in Fig. 124. The bridge shown in this figure can be made by using two-wire transmission line. A transposition is made at point *C*. Points *E* and *F* are the same distance from points *A* and *B* as points *G* and *H*. If radio-frequency voltage is introduced at points *I* and *J*, and if the

bridge is balanced, a perfect voltage node will exist at points *A* and *B*. Current will flow, but the voltage between points *A* and *B* will be zero. Radio frequency could be introduced at points *E* and *F* by the transformer connected thereto, and an amplifier could be connected at points *A* and *B*. The output of this amplifier could be connected to points *I* and *J*, and if a proper terminating impedance were added at *G* and *H*, there would be no feedback in the amplifier.

In the CAA-I.T.D. localizer, the output of the transmitter is connected to such a bridge (Fig. 125). Coupled to two arms of the bridge are two sections of transmission line. Connected

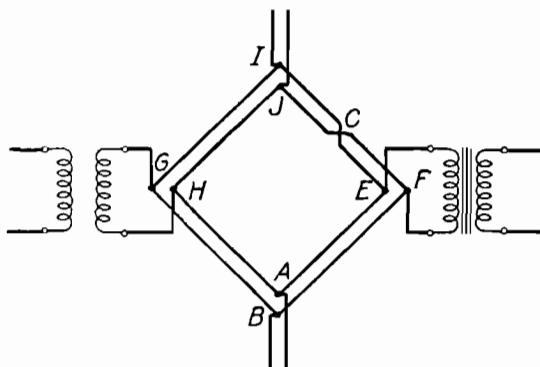

FIG. 124.—Radio-frequency bridge constructed of two-wire transmission line.

to these lines are condensers consisting of two plates. Between these plates rotate star-shaped metal disks. One of these plates has five segments, and the other has three segments. These segments are driven by a common motor to generate 90 and 150 cycles. Because of the bridge connected to the transmitter, there is no reaction from this keying at the transmitter. That is, at the output terminals of the transmitter there appears only the fundamental frequency without any cross modulation. In the transmission lines connected to the two arms of the bridge there will appear, however, the fundamental frequency and the modulation products. These transmission lines are connected to a second bridge. This bridge serves to combine the modulation products without introducing reaction between the modulating elements, and it also serves to introduce proper phase shifting. At one terminal of this bridge there is connected the central loop. The current in this loop consists of carrier and

side-band frequencies of equal intensity and in phase with each other. To the other terminals of the bridge there are connected two outer loops. These loops are connected in parallel with each other and are spaced from the central loop by a distance equal to 165 electrical degrees. The currents in these loops may be considered to have three components. One of these is the carrier-frequency component which is equal to four-tenths that in the central loop and in phase with it; the second com-

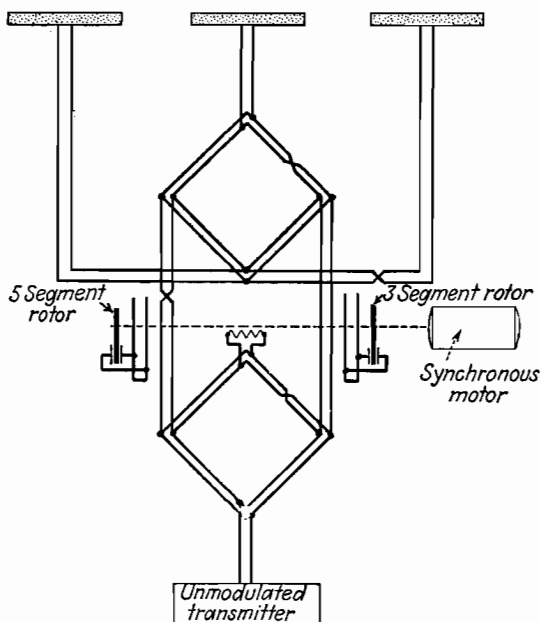

FIG. 125.—Simplified schematic of the CAA-I.T.D. localizer system.

ponent is the side-band current also having an intensity equal to four-tenths that in the central loop and in phase with it; and the third component is a side-band component having a magnitude 0.73 times the side-band current in the central loop and phased 90 deg. from it. The connections to one outer loop are reversed so that the current in it is 180 deg. out of phase with that in the other outside loop. All these components add in space to form an elliptically shaped carrier field pattern and two cardioid-like side-band field patterns. The comparison of the intensities of the side bands forms the on-course. The resulting

course is very sharp. The difference between the field strengths of the 90- and 150-cycle modulation is approximately 1.5 db at 1.5 deg. off course.

CAA Localizer Receiver and Transmitter.—The transmitter used with this system is similar in all respects to the glide-path transmitter except that there is no modulation. That is, the carrier comes from the transmitter in an unmodulated form to be acted upon by the mechanical modulators previously described. The frequencies of these transmitters lie in a narrow band centered about 110 megacycles. More than one frequency is available in order to avoid interference when installations must be made at several airports located within a short distance of each other.

The signals from this transmitter were received on a special crystal-controlled receiver during the original experiments, but it is intended that the same receiver used to receive radio-range stations be used under conditions of practical airline operation. This receiver is described in Chap. III. Its output is separated with 90- and 150-cycle filters and applied to the vertical needle of a cross-pointer instrument. This same instrument also gives radio-range indication when the receiver is used for flying the two-course radio range.

CAA-I.T.D. Marker System.—Two markers are used—one located at the boundary of the airport and the other 2 miles from the boundary. These markers operate on 75 megacycles and are received by the marker receiver described in Chap. V. These markers have a fan-shaped pattern and are modulated with 400 and 1,300 cycles. The transmitters used for these markers have a power output of 5 watts, although only 2 watts are required. They are crystal controlled. The entire transmitter is housed in a small box 18 in. high, 27 in. wide, and 15 in. deep. This box is waterproof and is not housed, but is located near the marker antenna array.

Monitor System.—All the equipment used with the *CAA-I.T.D.* system is controlled from the airport tower. A desk is fitted with controls, enabling an operator to turn on any piece of equipment. On this same desk are a series of calibrated instruments indicating the quantity and quality of the signals being radiated from each of the system's facilities. In addition to this indicator there is a set of visual and aural alarms which indicates if

the localizer course and glide path shift to such an extent as to cause the airplane following these signals to land off the runway.

Six additional systems of this type have been manufactured, and ten more have been purchased.

The CAA-I.T.D. system should be remembered as introducing the controllable isopotential glide path, its elaborate monitor system, and the unusual principles employed in the localizer.

The CAA-M.I.T. Instrument-landing Development.—In about 1938, the CAA arranged with the Massachusetts Institute of Technology for the development of an instrument-landing system(5) based on principles different from those previously described. Since M.I.T. is not a manufacturing establishment, it set out to develop certain principles that might be applied commercially to a practical system. This project was completed in 1941, and a description of some of the work has been published. Some of the developments will now be described, but these should be considered as principles to be incorporated in a commercial instrument-landing system rather than integral components of an established system.

The CAA-M.I.T. Glide Path.—Regardless of the excellence of the transmitting and receiving components of an isopotential glide-path system, the fact that the shape of this glide path is a function of the gain of a receiver and the power output of a transmitter will always remain. The ideal system is one in which there can be no change in path regardless of these field-strength and gain factors. When the Bureau of Standards began their work, they set out to produce a visual system of glide-path indication that would operate on the relative strength of two lobes of signals. This is the same principle that is used for localizers. As described in Chap. II, their means for producing such a system were poor, so they discontinued work along this line of development and transferred their efforts to the isopotential path because it offered more promise. With the later developments that have been described, the equisignal path appeared practical to the M.I.T. men. They had spent considerable effort in the development of electromagnetic horns(6) (previously described under Markers, Chap. V) and so used two of these to produce two lobes of energy at about 700 megacycles.

Figure 126 shows two lobes of energy. Although these can best be produced by electromagnetic horns using microwaves, it can be seen that they are similar to the field-strength patterns produced by previously described antenna arrays of the isopotential glide path. The glide path is the locus of a series of connected points where the field strengths from both energy lobes are equal. By using this method it can be seen that the resulting path is a straight line, because there is only one angle where the field strength from both radiators is equal. The two horns were mounted so that the lower edge of the mouth of each touched the ground, but one was tilted at 5 and the other at 10 deg. By changing the relative sensitivities of the 90- and 150-cycle channels in the receiver, the glide path could be changed between the angles of 6 and 11 deg. Horizontally polarized waves were



FIG. 126.—Vertical-field pattern from two electromagnetic horns.

used. If the two lobes of energy are produced by the same transmitter, reduction in the transmitter power would bring about equal reduction in the dimensions of the lobes of Fig. 126; hence the path would not change. Actually, M.I.T. made use of two transmitters operating on different carrier frequencies. The frequency separation of these two carriers was sufficient to prevent cross modulation and yet close enough so that both could be received on the same receiver. The transmitters were modulated by mechanical "choppers" inserted in series with the center conductors of the transmission lines connecting the transmitter to the horns. Frequencies of 90 and 150 cycles were used, and these were separated in the receiver by the use of filters. It can be seen that such a system would have as many or more variables as the isopotential glide-path system, but there is no reason why a system similar to that used in the I.T.D. localizer could not be used successfully to produce this glide path.

CAA-M.I.T. Localizer.—The localizer that was used with this system was quite similar to the glide path previously described,

except that two horns were used to produce overlapping horizontal field patterns rather than vertical patterns.

Transmitter.—Although some work was done using a Klystron (velocity-modulated tube) oscillator, most of the work utilized a triode oscillator in a more or less conventional circuit. The power output was between 1 and 5 watts; however, the tremendous power gain of 50 secured by using the electromagnetic horn produced a field strength of about 1 mv. per meter at a distance of 10 miles.

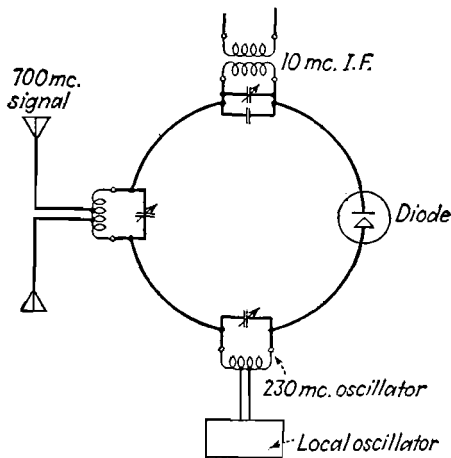

FIG. 127.—Receiver for 700 megacycles developed for the CAA-M.I.T. instrument-landing system.

The Markers.—No marker system specifically intended for use with this system was developed; however, the results of tests with markers associated with this system were described in Chap. V.

The Receiver.—A superheterodyne receiver was used with the carrier frequency fed directly into the converter. Here it mixed with the third harmonic of the oscillator to produce a 10-megacycle intermediate signal. A special diode is used as the mixer tube. A schematic circuit of this receiver is shown in Fig. 127. A so-called "acorn" tube is used as the local oscillator. Two stages of intermediate-frequency amplification are used followed by a detector from which the audio frequency appears. The gain of the intermediate-frequency amplifier is approximately 74 db with a 300-ke. band width. A small amount of automatic

gain control is employed. The second detector is followed by four stages of resistance-coupled audio amplification which is equipped with automatic volume control. This control is such that the output of the receiver remains substantially constant for input signals varying from 3 mv. to 3 volts. Following this audio amplifier the 90 and 150 cycles are separated by the use

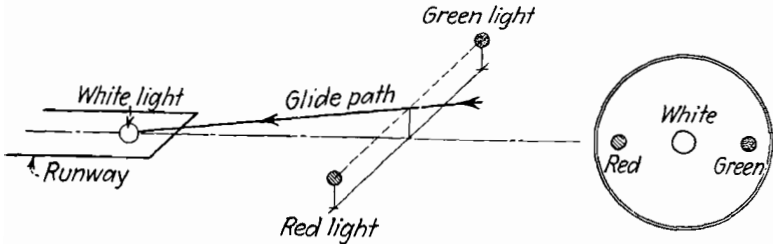

FIG. 128.—When an airplane is at the correct glide angle and in the middle of the runway, the pilot sees the three lights on the ground in the configuration shown.

of filters, and each output frequency passes through individual amplifiers. By changing the gain of these amplifiers, the glide-path angle may be changed. This feature is, of course, purely for experimental use.

The Indicator.—A novel feature of this system is the indicator. Based on the geometric theorem which states that three points

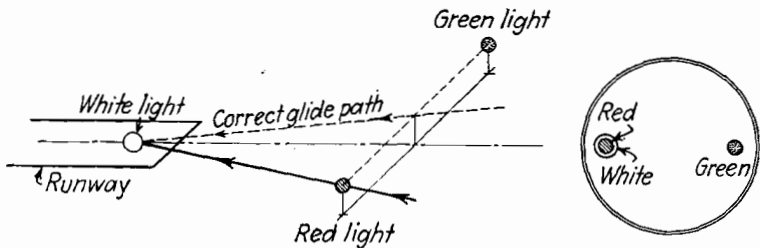

FIG. 129.—The center light appears to coincide with the light on the left when the airplane is at the correct descent angle but to the left of the glide path.

determine a plane, an airplane can make a landing by observing the apparent position of three spots of light as the descent is made. This principle is illustrated by Figs. 128, 129, and 130. If a pilot is directly on the path in line with the middle of the runway, he will see the three lights appear in line, and with the center light exactly between the two outer lights. This is

illustrated by Fig. 128. If, however, the airplane is approaching at the correct angle but is to one side, two of the lights will coincide and the third will appear to one side as shown by Fig. 129. If the airplane is in line with the middle of the runway but is above the glide path, the center light will appear in the center and above the two outer lights, as shown in Fig. 130. In this development it was intended that spots on a cathode-ray tube be used to simulate the lights. By successively commutating from one element of the instrument-landing system to the other, each facility actuated one spot of the cathode-ray tube. In the actual instrument the localizer receiver served to move the white spot to the right or left and the glide path receiver

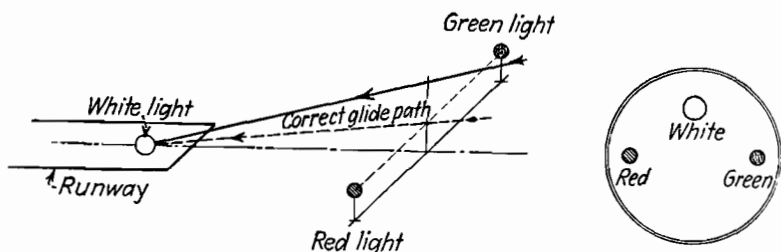

FIG. 130.—If the airplane is in line with the runway but above the correct line of descent, the center light appears as shown.

served to move the white spot up and down. The red and green spots were actuated by the artificial horizon gyro which gave roll and pitch orientation, while a directional gyro indicated heading.

Other Systems.—In order to complete the chapter, other instrument-landing systems(7) that have been developed should be mentioned.

The Lorenz System.—This system was developed in Germany in about 1933 and made use of vertical polarization at ultra-high frequencies for the glide path and used both visual and aural localizer indications.

The Washington Institute of Technology System.—This system was developed in about 1933 by a group of engineers who had been associated with the Bureau of Standards development. It had many forms as its development progressed. Both low-frequency and ultra-high-frequency localizers have been developed. The glide path used is the conventional curved glide path using ultra-high frequencies. This system advocated the

location of all equipment on a trailer which could be moved about to serve several runways.

The Dingley System.—This system made use of audio frequencies from two buried cables. It is the only radical departure from the systems described in the earlier part of the chapter.

Low-approach Systems.—These systems constitute means for beginning a landing under conditions of low ceiling(7), but since they do not have a path leading to the ground, they are not true landing systems. In the main they consist of a localizer and markers. A sensitive barometric altimeter provides the only height indication. In this group must be mentioned the developments of the Airways Division of the Department of Commerce in 1933 and those of the United States Army in about the same period.

In addition to the systems mentioned, a large number of developments were begun but never fully completed.

Problems

1. Use the data of Fig. 112, and plot the isopotential glide path, assuming that when the distance is 1,500 ft. the field strength is unity and $h_1/d_1 = \tan 2^\circ$.
2. Plot a glide path similar to that of Fig. 113 using curve *B* of Fig. 114.
3. Determine the constants for Eq. (124) when applied to curve *C* of Fig. 114.
4. Discuss in detail the relative advantages of low-approach versus instrument-landing systems.

Bibliography

1. DIAMOND, H., and F. W. DUNMORE: A Radio Beacon and Receiving System for the Blind Landing of Aircraft, *Proc. I.R.E.*, April, 1931, p. 585.
2. DIAMOND, H.: Private correspondence.
3. JACKSON, W. E., A. ALFORD, P. F. BYRNE, and H. B. FISCHER: The Development of the Civil Aeronautics Authority Instrument Landing System at Indianapolis, *A.I.E.E. Tech. Paper* 40-43, December, 1939.
4. ALFORD, A.: High Frequency Bridge Circuits and High Frequency Repeaters, U.S. Patent No. 2,147,809.
5. BOWLES, E. L., W. L. BARROW, W. M. HALL, F. D. LEWIS, and D. E. KERR: The C.A.A.-M.I.T. Microwave Instrument Landing System, *A.I.E.E. Tech. Paper* 40-44, January, 1940.
6. BARROW, W. L., and F. D. LEWIS: The Sectoral Electromagnetic Horn, *Proc. I.R.E.*, January, 1939, p. 41.
7. JACKSON, W. E.: Report on the Status of Instrument Landing Systems, *CAA Tech. Development Rept.* 1, October, 1937.

CHAPTER VII

ABSOLUTE ALTIMETERS

Since the advent of aircraft, the method used for determining altitude has been the aneroid altimeter. This device consists merely of an expansible chamber geared to a pointer. This pointer deflects proportionally to the pressure exerted on the chamber by the surrounding air. Of course the deflection of this meter bears no direct relation to the distance between it and the terrain below. The meter is calibrated to read in feet, "standard" air conditions being assumed. An adjustment for the known conditions of the air is provided. At terminals the ground-station personnel advise the pilot by radio of the barometric pressure existing on the ground, and the pilot makes this adjustment on his altimeter. The altimeter then reads the approximate elevation of the airplane above sea level, and if the elevation above sea level of the ground directly below is known, it is possible by subtraction to determine the height of the airplane above the ground. In order to know accurately the distance between the airplane and the ground below, it is necessary to know, in addition to the reading of the meter, the air pressure and temperature. Consequently, it can be seen that the aneroid altimeter cannot be trusted as an indicator of the proximity of the adjacent terrain.

A reasonable question concerns the necessity for knowing this height with such great accuracy. Some of the first references to altimeters that would read the distance to the terrain below (known as absolute altimeters) mentioned their use as landing aids. When instruments were first used to make flights above and through overcasts, many accidents occurred because the airplane deviated from true course and collided with high-altitude terrain. Flying at that time was permitted at altitudes lower than the adjacent terrain, and often the course was through canyons where small deviations caused collision. Flying at altitudes sufficient to clear all adjacent terrain was not commonly

practiced because of the characteristics of the older airplanes and their lack of oxygen equipment. Later, high-altitude flying became a rule, but the absolute altimeter was again considered as an independent means for checking instrument-landing systems.

The necessity for an instrument of this character was recognized by inventors and many patents have been granted covering these devices. Currently, however, only one such apparatus unit is available commercially. Much of the work done on these devices followed three principles. These are the speed of sound and its reflection from a hard surface; the change in the specific capacity of a condenser with the variation of the proximity of a conductor (the earth); and the speed of radio waves, together with their reflection by the earth. Commercial models that utilized two of these three principles were produced.

Principle of the Sonic Altimeters.—The use of sound as a means for measuring distance followed from the successful use of this principle as a sounding device on boats (see Fig. 131). Briefly, it consists of a powerful sound generator from which sound is transmitted down from the airplane to the ground. This sound is reflected by the ground, and the returning echo acts upon a sensitive detector. The sound emitted from the generator is (with one exception) in the form of a short pulse so that it has ceased before the reflected sound reaches the detector. The third item in this instrument is a device that measures the interval between the time that the sound leaves the generator and reaches the detector. This indicator is calibrated to read directly in feet.

Sound Generators.—Because of the high level of the noise from the aircraft motors and propellers and the loss in intensity of the generated sound as it travels to the ground and returns, it is necessary that the initial sound intensity emitted by the generator be high. In order that the sound generator may be light and yet very powerful, special designs are required, and these designs have been the subject of much attention by the various inventors. Chemical, electrical, mechanical, and compressed gas supplies have been used for generating the sound(1). In all but one design it was possible for the generator to store energy between pulses and release this energy in a single powerful burst.

In the "Behmplot" apparatus the transmitter consisted of a pistol that was fired at intervals. This system produced a very intense sound, yet the sound-generator weight was low, provided that only a small number of soundings were taken. This device was developed as early as 1924. Of course, the sound from this equipment had a random frequency range. The duration of this sound is not known, but it was emitted at

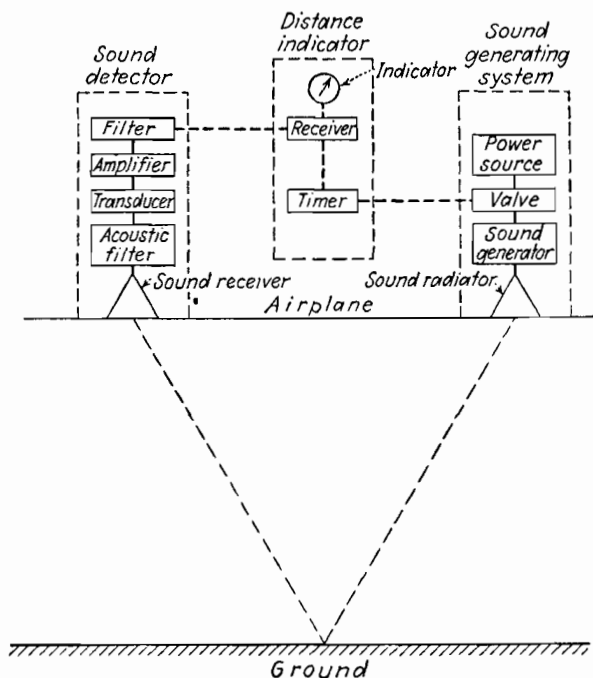

FIG. 131.—Principal elements used in sonic altimeters.

3-sec. intervals. In 1928, Nandillon worked on a sonic-altimeter development utilizing an armature-excited directive diaphragm without a horn. A constant frequency of 3,500 cycles was emitted at intervals of about 0.005 sec. These intervals were manually variable with the altitude. Rice of the General Electric Company produced the only near-commercial device in the United States. This unit was flight-tested by United Air Lines in 1933 and 1934, although work was done on it as early as 1929. Literature available states that compressed gas was bled from the engine cylinders and stored under pressure

to be later used in actuating a whistle. However, the General Electric unit tested by United Air Lines used an electrically actuated hammer and anvil. The frequency of the whistle is reported as 3,000 cycles per second for a duration of 0.01 sec. repeated at intervals of 2 sec. This same characteristic applied approximately to the anvil generator. Work was also done in 1931 by Florisson of the Société de Condensation et d'Applications Mécaniques of Paris. His generator also consisted of a whistle and a conical horn. A small air compressor was carried for the purpose of supplying air for the whistle. The frequency of the whistle is not known, but it had a duration of about 0.03 sec. and was repeated at intervals of 1.1 sec.

Dubois-Laboureur in 1932 developed a device for the Constructions Électro-mécaniques d'Asnières using a siren with a constant frequency of about 1,500 cycles per second. This sound had a duration of 0.013 sec. and was repeated at 0.7 sec. at low altitudes and 2 sec. at high altitudes. Also in 1932 Jacques-Badin worked with an electromagnetically excited diaphragm attached to an exponential horn. This system differed from the others in that the 200-cycle note was emitted continuously. In 1934, Delsasso used a mechanically excited diaphragm with a 2,000-cycle note and a duration of 0.02 sec. The "Echoscope" developed sometime prior to 1936 used a compressed-air-driven siren and parabolic horn emitting a 200-cycle note for a period of 0.02 sec. and repeated at an unknown interval.

Sound Detector.—The devices that have been used for sound detectors on the various sonic altimeters are as many and as varied as the devices that have been used for sound generators. The Behm lot made use of a carbon microphone at the end of a horn, whereas Nandillon used an electromagnetic microphone. Literature reports Rice using a stethoscope, earpieces, acoustical filter, and horn, but the device tested by United Air Lines used an electromagnetic receiver, horn, wave filter, and amplifier. Essentially the same equipment was also used by Dubois-Laboureur and Jacques-Badin. The latter group secured further filtering by the use of an acoustical filter in addition to the electric filter, whereas the former used a tuned diaphragm on the microphone for the same purpose. Florisson used the system reported for Rice but added an additional acoustical filter. Delsasso used an electrical contact on a resonant diaphragm,

whereas the Echoscope, like the Dubois-Laboureur device, used a tuned electromagnetic microphone. It can be seen that the means employed for detecting the reflected sound in the presence of the noise from the motor and propellers was the use of an audio frequency appreciably different from the major sound components of the airplane noise and filters for separating the generated frequency from the noise components. Because of the random frequency spectrum of the sound generated by the gun, a filter could not be applied to the Behmplot system. The fact that the Nandillon system is not described as using a filter is not significant because of the limited information on this secret development. All the other systems used filters. Three different types of filters—tuned diaphragm, electric, and acoustic—were employed by the Jacques-Badin device.

Distance Indicators.—The distance indicators for the sonic altimeters are, of course, time-interval indicators calibrated in feet. Some of the devices used automatic indicators, and others required manipulation or continuous observation by the operator. In the early Behmplot system a dial rotating continuously at a constant speed was employed. The operator noted the time when he discharged the cartridge and again when he heard the reflected signal. Later this system was improved by connecting an optical attachment to the indicator. This optical system was quite ingenious. As the gun was fired, an electromagnet released a spring-actuated pointer which traveled across the scale at a constant speed. To this pointer there was attached a mirror which reflected light from a small lamp to a translucent scale. When the reflected signal was received, it was amplified and applied to an electromagnet which in turn actuated a mechanical reed. At the end of this reed was a lens positioned in front of the small lamp. The motion of the lens caused a deflection of the light beam and produced a positive indication on the translucent scale. Florisson used an indicator similar to that employed in the early Behmplot system, except that an auxiliary pointer was added to indicate the position of the timing hand when the sound was generated. This was later replaced with a light traveling across a scale, which was extinguished when sound was heard.

In the Nandillon system an indicator similar in principle to those described was used. The timing motor drove a lamp,

located at the end of an arm, at a constant speed. For one position of the lamp a contact was made which energized the sound generator. When the sound reached the detector, it was amplified and used to energize a magnet located below the lamp and actuating a shutter on it. The resulting spot of light was visible on a translucent scale in front of the lamp assembly. Indicators of this type are known as chronoscopes and were used in modified forms by Delsasso and in the Echoscope as well as by the investigators previously mentioned. In each case there is a constant-speed motor driving an indicator. When the returning sound wave reaches the detector, its presence is announced by a visual or aural sensation. The position of the indicator is noted, and its deflection from the starting point is proportional to time elapsed or distance to the ground. The indicator for the early Behmlot system was merely an aural indicator combined with a pointer, the Florisson used a light that was carried by the constant-speed motor and was extinguished, the Nandillon a light controlled by a shutter, the Delsasso a neon lamp illuminated by the signal, and the Echoscope a mechanical pointer actuated by an electromagnet which is de-energized by the returning sound.

The General Electric system tested by United Air Lines was intended primarily for use with instrument landing and did not have a direct indicator. The pilot noted the time that elapsed between the time when he heard the direct sound and the time when he heard the reflected sound, and it was intended that he learn to associate acoustically this time with altitude. The theory behind this procedure was that the pilot cannot know directly his altitude as he looks out but is, nevertheless, able to make a landing; hence he should be able to learn to associate his distance with an aural impression. By using a long tube between the receiving horn and the microphone of the detector, the accuracy of the instrument at low altitudes was increased, so when the pilot heard the direct and reflected signals coincide, he knew he had reached some predetermined terrain clearance.

The Dubois-Laboureur system made use of an electronic indicator. The circuit for this device is shown in Fig. 132. In this circuit, *G* is the air-driven generator, which is a governor-controlled motor-driven siren. The motor that drives the siren also serves to operate the air valve *V*. The end of the valve

shaft also serves as a commutator. Normally a battery B_1 is connected through the contacts K_1 of the valve shaft to the relay K_2 . This causes K_2 to hold its contacts open, but when the valve shaft moves and furnishes air to the siren, the contacts at K_1 open and allow the relay contacts to close. These contacts short-circuit condenser C and microphone M . The momentary break in the current through the relay induces a voltage in the secondary of transformer T_2 . This surge in the secondary is sufficient to cause the neon tube N_1 to conduct, allowing current to flow through R_1 from B_2 . The second neon tube N_2 merely serves as a voltage regulator. The potential developed across R_1 causes the condenser C to be charged (after K_2 has again

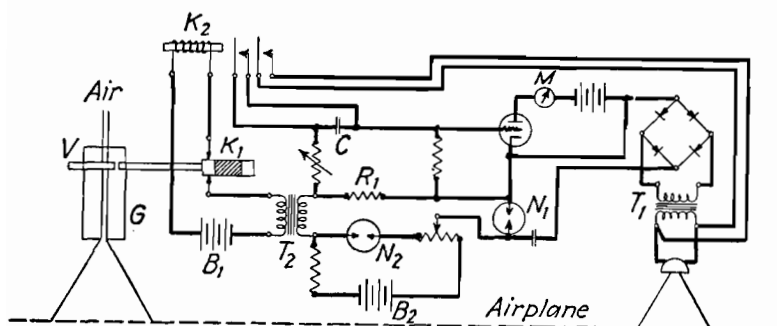

FIG. 132.—Electronic indicator used with the Dubois-Laboureur sonic altimeter.

closed), and as the charge on this condenser grows, the plate current of the vacuum tube increases. When the sound is received by the microphone, it is rectified by the copper oxide rectifier, and this voltage applied to N_2 causes the potential across it to be reduced, and N_1 stops conducting. This process is continuous, so the reading of the meter M is a function of the average charge on the condenser C , which in turn is a function of the length of time between the period when C was discharged and when N_1 stopped conducting, that is, the period of time between the generation of the sound pulse and its detection.

A number of these indicators give only an intermittent indication. That is, the indicator gives a true reading only when the sound returns, after which the pointer, lamp, etc., are no longer energized. In the methods using light, an impression of continuous indication can be obtained if the pulses are sent out at a

speed greater than the persistency of vision. Jacques-Badin used a system in which a single pulse is sent out, but the generator is not further energized until the signal returns. Upon returning, the received pulse automatically operates the switch controlling the energy to the sound generator, thereby sending out a second pulse. The rate at which these pulses are sent out is a function of the distance to the ground; that is, if the time between the sound transmission and reception is zero, the signal would be sent out continuously. The frequency at which these pulses

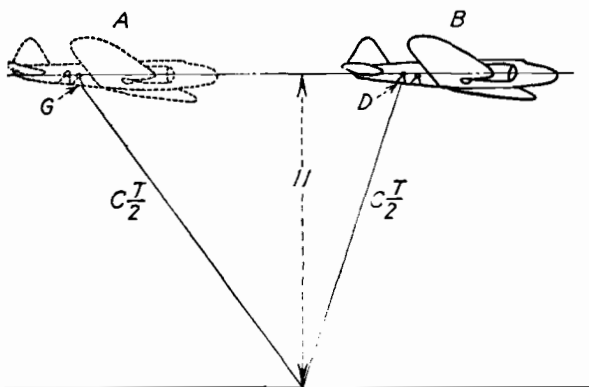

FIG. 133.—Because there is a change in the position of the aircraft between the time that a signal is transmitted and an echo is received, an error is introduced in the reading of a sonic altimeter.

are sent out is measured with a direct-reading frequency meter which is calibrated in feet.

Errors in Sonic Altimeters.—There are a number of factors that enter to cause error in sonic altimeters used for aircraft. Some of these are due to change in the sound velocity with variation in temperature and pressure of the air, separation between sending and receiving units, inclination of the flight path, the velocity of the aircraft, and instrumentation errors. With accurate time-measuring devices to minimize instrumentation errors, it can be shown that all the errors are negligible for altitudes in excess of 30 ft. The speed of the aircraft, however, is continually increasing, and speeds in excess of 500 m.p.h. are now mentioned; so their effect on the performance of the sonic altimeter will be discussed at this time. In Fig. 133 is shown an airplane sending out a sound pulse when in position *A*, but it has reached position *B* before the sound is detected.

If the speed of sound is C , in time T it will have traveled a distance

$$D = CT \quad (127)$$

In this same time, the airplane has traveled a distance AB , and if the altitude is H , this expression follows from geometry:

$$\frac{CT}{2} = \sqrt{\left(\frac{AB}{2}\right)^2 + H^2} \quad (128)$$

If the airplane had been traveling at a speed S , then

$$C^2T^2 = S^2T^2 + 4H^2 \quad (129)$$

or

$$T = \sqrt{\frac{4H^2}{C^2 - S^2}} \quad (130)$$

The altimeter, however, is calibrated for a distance of $2H$. That is, the chronometer reads

$$T_c = \frac{2H}{C} \quad (131)$$

The ratio of the actual time to the calibrated time is then

$$\frac{T_A}{T_c} = \sqrt{\frac{C^2}{C^2 - S^2}} \quad (132)$$

From this expression it can be seen that the error would be infinite when the speed of the airplane reaches the speed of sound. That is, at this speed the sound would, of course, never reach the airplane. With an airplane speed of 500 m.p.h., or 730 f.p.s., the error is approximately 33 per cent. This calculation assumes that the distance between the transmitter and the receiver is negligible and that the speed of sound is 1,100 f.p.s.

Limitations of Sonic Altimeters.—One of the limitations of the sonic altimeter has already been discussed in the previous section. As the speed of the airplane increases, the use of sound as a distance-measuring device becomes less practical and cannot be used when the airplane has reached the speed of sound. The comparatively slow speed of sound also limits the maximum useful altitude. On the assumption that there are no other problems, the length of time required to secure an indication

is excessive at high altitudes. A modern transport airplane traveling at a speed that will be regarded as slow in the future covers a mile in about 20 sec., yet this same amount of time is required for the sound to reach the ground and indicate in the cockpit of an airplane flying at the common altitude of 11,000 ft. This factor alone would render the sonic altimeter ineffective as an en route flying device. Another factor limiting the usefulness of the sonic altimeter is the amount of power required in order to overcome the noise of the aircraft motors. If the sound transmitter is considered to be feeding its energy to a cone, the apex of which is the sound source, then the following equation may be written:

$$p = 134 \frac{\cos \delta}{H} \sqrt{\frac{W}{1 - \cos \phi}} \quad (133)$$

where H = height, feet

p = sound pressure, bars

W = sound power, watts

ϕ = half the angle of the cone of sound

δ = angle between cone axis and the vertical

From this expression it can be seen that the angle of the cone of sound should be kept small; that is, the energy should be concentrated in as small an area as possible. For constant values of p , ϕ , and δ , the following equation may be written:

$$W \propto H^2 \quad (134)$$

That is, the amount of power varies as the *square* of the height. Aside from these factors, sound is absorbed (for 300-cycle tones) at a rate of about $\frac{1}{2}$ db per hundred feet, and about 7 db are lost during the reflection at the ground. It can be seen that for high altitudes the sound power required alone renders the device impractical.

Performance of Sonic Altimeters.—Sound powers of the order of 100 watts were used in some of the altimeters constructed. With this power, performance is reported for altitudes as high as 1,400 ft. Without exception, readings at this elevation were made in airplanes with engines idling or in lighter-than-air craft with the motors shut off. The usual practical altitude with airplanes flying at high speed was more nearly 150 ft. The weight of these devices varied with the source of power employed. Weights

reported varied from 20 to 61 lb. The maximum altitude (for any condition) to gross-weight ratio varied from 8 to 48 ft. of elevation per pound of weight.

Commercial Availability.—The only unit advertised as commercially available in this country was the Rice-General Electric device. It is believed that this item was discontinued in about 1934. The Behmplot and the Echo-scope were available in Germany in 1935, and the Florisson-SCAM and the Dubois-Laboureur-CEMA were available in France in 1933.

FIG. 134.—Capacities which exist between the electrodes of a capacity-type altimeter when the airplane is in free space.

The Capacity Altimeter.—During the period when extensive development of the sonic altimeter was undertaken, work was also done on altimeters utilizing the capacity principle. It appears, however, that most of this work was done by or associated with branches of the United States Services, and no extensive literature covering this subject has been published. It is not known whether Europeans worked along this line of endeavor.

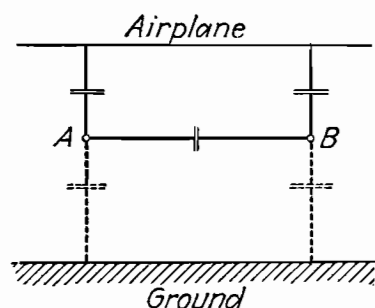

FIG. 135.—Capacities which exist between the electrodes of a capacity-type altimeter when the airplane approaches the earth.

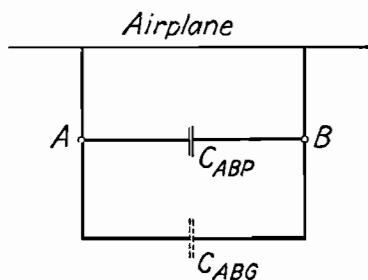

FIG. 136.—Equivalent capacities existing between the electrodes of a capacity altimeter for the condition shown on Fig. 135.

The capacity altimeter makes use of two conductors or plates mounted on a supporting structure outside the airplane. Electrically, then, these conductors will have capacity to the structure of the airplane and to each other. This is shown in Fig. 134. The conductors are A and B , and there exists a capacity A to the airplane, B to the airplane, and between A and B . As

the airplane arrives from free space to proximity with the ground, two other capacities appear—one from each conductor to ground as shown in Fig. 135. The three capacities of Fig. 134 are equivalent to a single capacity between the conductors, which equivalent capacity is shown in Fig. 136 as C_{ABP} . The capacities between individual conductors and ground can be grouped as C_{ABG} . The latter capacity varies with the distance of the airplane from ground, and the development of the capacity altimeter consists in devising an accurate means for measuring the change to this capacity with change in altitude.

Magnitude of Capacity.—If the diameter of the conductors forming the condenser plates in a capacity altimeter is small compared with the length, the following formula(2) expresses the capacity of these wires to ground:

$$C = \frac{0.2416L}{\log_{10} (2L/d) - k_2} \quad (135)$$

where C = capacity, micromicrofarads
 L = length of conductor, centimeters
 d = diameter of wire, centimeters
 h = height above ground, centimeters

$$k_2 = \log_{10} \left[\frac{L}{4h} + \sqrt{1 + \left(\frac{L}{4h} \right)^2} \right]$$

Assuming that a wire having a diameter of 0.2 cm. and a length of 250 cm. is used for a conductor, the capacity of this wire when 10 and 100 ft. aboveground will be 20.7 and 20.2 $\mu\mu\text{f}$, respectively. It can be seen that the capacity change will be extremely small, and special means must be employed in order to detect these changes.

The Gunn Altimeter.—An altimeter of this period was developed by Dr. Ross Gunn of the Navy and is briefly described in the literature(3). This device gave successful readings to altitudes of 100 ft., and with additional development it was thought possible to increase this altitude to 200 ft. A circuit(4) of the Gunn device is shown in Fig. 137.

Referring to this figure, a radio-frequency oscillator composed of coils L_1 , L_2 , tuning condenser C_1 , and vacuum tube V_1 feeds power to an external circuit via coupling coil L_3 . This energy is connected to two differentially wound coils L_4 and L_5 .

These coils are tuned by condensers C_2 and C_3 and couple energy to coil L_6 . Since the voltage induced in coil L_6 is a function of the current in coils L_4 and L_5 and since these coils are identical and differentially wound, no voltage will be induced in L_6 if the currents in these coils are equal. The magnitude of this induced voltage is indicated by meter M of the vacuum-tube voltmeter composed of V_2 , R_1 , M , and the necessary batteries. Across coil L_5 there are attached two wires forming the external condensers. The condensers C_2 and C_3 are adjusted when the

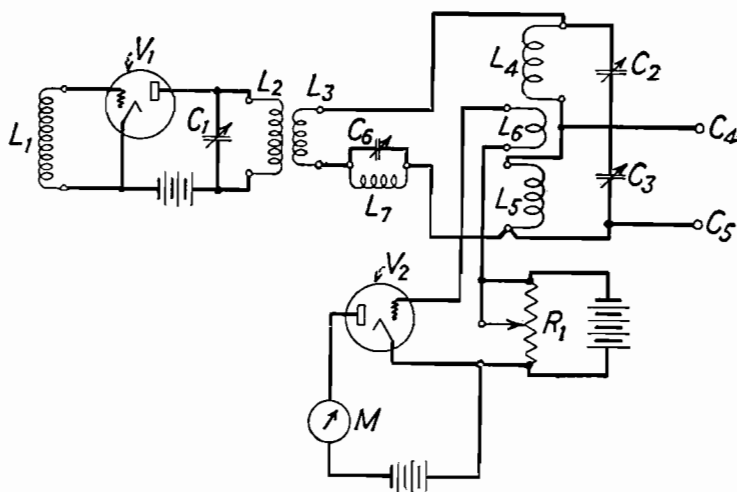

FIG. 137.—The Gunn capacity-altimeter circuit.

airplane is on the ground so that the voltage induced in L_6 is minimum. The effect of voltage remaining is cancelled by an adjustment of the vacuum-tube voltmeter bias, which is controlled by potentiometer R_1 . After the airplane leaves the ground, the capacity across C_4 and C_5 decreases, thereby causing an unbalance in the currents because the current in L_5 decreases. A voltage is developed therefore across L_6 which causes a deflection in meter M proportional to the unbalance and, hence, proportional to the height. In order to accentuate this unbalance an additional tuned circuit consisting of coil L_7 and condenser C_6 is added in series with coupling coil L_3 . This circuit is parallel resonant and, hence, keeps the current through L_4 and L_5 to a low value. Because of the high Q of coil L_7 , changes in C_2 and

C_3 produce detuning of this circuit and increase the current through L_4 and L_5 , and, hence, the current unbalance.

Results of Capacity Altimeter Development.—There seems to be no record of commercial-capacity altimeter installations. Publications give the weight of one of these devices as 20 lb. Obviously this weight is very low, so it could not have been the limitation of the device. Consideration of the problem involved indicates, however, that extreme stability, both electrically and mechanically, is necessary for proper operation of the device. Literature mentions the effect of wing flexure as a source of instability; hence, all components must be very small in order that capacity values remain fixed. It is doubted that these values could be maintained sufficiently stable for practical airline use where equipment must function day-in and day-out without attention by the designing engineers. Essentially, the device was satisfactory only as a landing aid, and was not suitable for en route flying. A device satisfactory for this purpose alone, but capable of withstanding service, would probably be somewhat heavier. Whether these considerations were the factors that prevented the capacity altimeter from becoming a successful commercial product is not known, but apparently no commercial production was attempted.

Radio Altimeters.—There are probably more patents covering various forms of radio altimeters than of any other absolute type. From all these patents, there is only one unit available on the market at this time, although the recent developments in microwave apparatus may introduce more. The unit now available or a modified form using microwaves may be adopted for commercial use in the future.

Early Radio Altimeters.—Early radio altimeters attempted to measure altitude by sending out a radio signal which was reflected from the earth and by reading the intensity of the reflected wave. This system met with little success for two reasons. One was that the intensity was as much a function of the terrain over which the airplane was flying as it was of the height above the terrain. The second was that there were standing waves produced in space, so the signal sometimes decreased as the altitude decreased. The latter difficulty could have been corrected by using a very low frequency, but the effectiveness of the radiation on the airplane (for a maximum allowable size) decreases as the

wave length increases, and the first difficulty discussed would not have been corrected by this means. The solution worked out consisted in using still shorter wave lengths and counting the number of nodes and antinodes in the standing wave through which the airplane passed as it ascended or descended. To illustrate, if a wave length of 100 ft. were employed at the transmitter and the airplane began its ascent and passed through two nodes (regions of minimum signal), the distance traversed would have been equivalent to three quarters of a wave length, or 75 ft.

The circuit(5) of Fig. 138 shows the apparatus used with one form of this device. This apparatus consists largely of a regener-

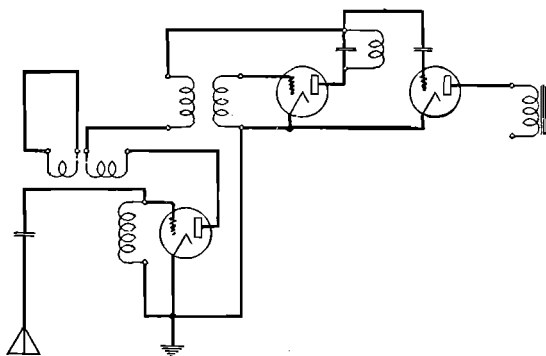

Fig. 138.—Circuit of the early radio altimeter.

ative receiver which serves as a transmitter as well as a receiver. The phase of the energy received serves to change (in a sinusoidal manner with altitude) the frequency of the device. This change is heard in the headphones. Increase and decrease of frequency as a function of altitude are shown in Fig. 139. Notice that the amount of deviation of the frequency from the mean also varies with altitude. This is because the amount of energy that returns decreases with altitude and, hence, affects the amount of deviation. The transmitted and received energies are separated by using a loop antenna that may be oriented for minimum direct pickup. The disadvantage of this system is immediately apparent because it is necessary for the pilot to remember the number of nodes through which the airplane has passed in the process of ascending and descending.

The Alexanderson Altimeter.—A device using a modified form of the principle described above was developed by Dr. E. F. W.

Alexanderson of the General Electric Company and was widely reported in many periodicals in 1928 and 1929. In this device(6), Dr. Alexanderson attempted to develop a mechanical "memory." Like many other altimeters of this period, its use as a means

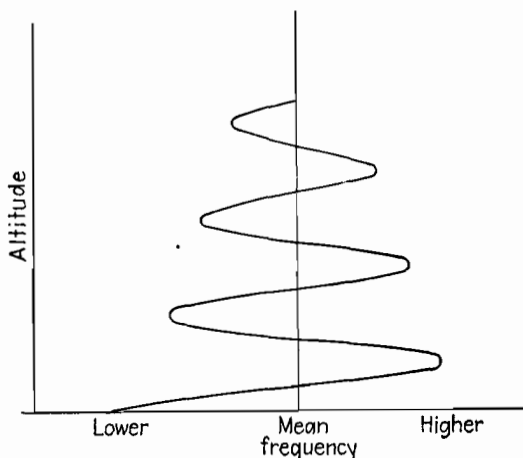

FIG. 139.—Change of frequency with altitude which occurs for the radio altimeter of Fig. 138.

for landing under low-ceiling conditions was the major purpose of the development.

Two oscillators were used in this device, their output frequencies beating together in a detector. These oscillators are

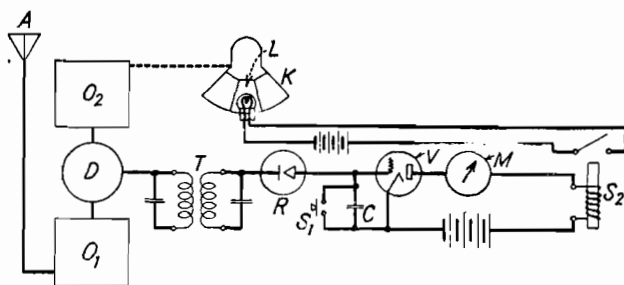

FIG. 140.—The Alexanderson radio altimeter.

shown as O_1 and O_2 in Fig. 140. Oscillator O_1 is connected to an antenna A . As the reflected wave reaches this antenna the frequency of O_1 varies, as has previously been described. This frequency beats with a fixed frequency from oscillator O_2 in

detector *D*. Actually O_2 has three frequencies that may be selected at will by manipulating control *K*. As *K* is moved, three windows of different colors are placed over light *L*. Transformer *T* is tuned to some frequency higher than the normal beat frequencies. This transformer is, in fact, a frequency discriminator and passes current proportional to frequency. This current is used to charge condenser *C* via rectifier *R*. This rectifier is inserted so that the charging mechanism will not discharge *C* even though, for the moment, there is no voltage from *T*. Thus, each time that a high-frequency peak (Fig. 139) is present, *C* charges and retains the charge. Each succeeding peak adds charge to *C*. As the charge on *C* increases, the plate current of the vacuum-tube voltmeter *V* increases and is recorded on the meter *M*. This plate current is normally zero because the grid of the tube is normally biased to the cutoff point by a bias battery (not shown). Thus, in a step-by-step process, meter *M* reads altitude. When the current flowing through *M* reaches a given value, the relay S_2 operates, thereby causing light *L* to be illuminated. This occurs at the point where *M* is reading full scale. At this time the pilot changes the frequency of O_2 , thereby increasing the range of the instrument. He must also press switch S_1 to discharge condenser *C*.

Apparently no commercial exploitation of this device was attempted; at least its sales were not publicized. The reason it was not installed extensively on aircraft was not discussed in contemporary literature. The maximum altitude of the device was between 3,000 and 4,000 ft., and this would appear to have been sufficient to make the device worth while. The weight involved is not known, but it probably was not excessive. A study of the instrumentation involved leads to the conclusion that excessive attention was necessary on the part of the pilot. Whether or not this conclusion is correct is not known.

History of the Western Electric Radio Altimeter.—This device, sometimes called the "terrain clearance indicator," is herein designated by the term "Western Electric" because it is being currently manufactured and sold by this concern. The responsibility for its development rests on a large group of individuals and several organizations. Actually, all these should be credited for its ultimate production. The fact that a unit accomplishing the feat attempted by so many previous experi-

menters was finally produced certainly is attended with honor sufficient for all involved. No doubt other devices (possibly more successful) will soon reach the market, but there is no denying that this unit was the first to be successfully demonstrated and sold on a commercial scale.

The commercial development of this device can be traced back to work done by Prof. W. L. Everitt of Ohio State University in 1928-1929 under a grant from the Daniel Guggenheim Fund for the promotion of Aeronautics(7). In this work the principles later utilized in the Western Electric device were fully developed. No successful commercial model resulted from this work, however, largely because of the radio frequency used and because the grant obtained from the fund was exhausted. Professor Everitt realized at that time the limitation of the frequency he employed, but current vacuum-tube technique did not permit the generation of appreciable power at very high frequencies. In 1930, Lloyd Espenheid of the American Telephone and Telegraph Company applied for a patent(8) on a device somewhat similar to that used by Dr. Everitt. The original application was divided in 1936, and a patent covering this device was issued in the same year. The extent of the development work done under this patent prior to 1937 is believed to be only a mathematical analysis by the Bell Telephone Laboratories (associated with the American Telephone and Telegraph Company). In the meantime, R. C. Newhouse, one of the students who had worked on the altimeter under Dr. Everitt, was employed by the Bell Telephone Laboratories. The communications Laboratories of United Air Lines were familiar with Newhouse's work and in 1937-1938 negotiated with the Western Electric Company for the development of such a device. Development work for the Western Electric Company is done by the Bell Telephone Laboratories, which organization had by this time developed tubes capable of producing appreciable power at frequencies in excess of 900 megacycles. Experienced personnel, equipment, and a patent were all available, so a successful model was developed and demonstrated to the public in the United Air Lines Laboratory airplane in the Fall(9) of 1938.

Principle of Weco Altimeter.—The principle of this altimeter can best be described by considering the space between the airplane and the ground as a two-wire transmission line with its

end open. If a voltage is connected across one end of the line, an electric wave will travel down it, reach the open point, and be reflected back to the source of the voltage. An appreciable length of time is required for this wave to travel from the voltage source to the open end of the line and back again, so when it reaches the source its phase will not be the same as the phase of the source voltage. This voltage will then add vectorially to the source voltage, making the terminal voltage either greater or less than the voltage of the generator when it is not connected to the line. This voltage, for a given length of line and for generators of the same characteristic impedance and open-circuit voltage, will vary as a function of the frequency employed. This fact follows because (although the time required for the electric wave to travel to the open terminal and return is the same for two different frequencies) if one of these is half the frequency of the other, the voltage at the lower frequency will rise from zero to some finite maximum peak value in the same time that the higher frequency voltage rises to a maximum and again decreases to zero. If the generator is made with a variable-frequency control and adjusted first to a frequency that gives maximum voltage then to the next successive frequency again producing maximum voltage, it will be found that the difference between the two frequencies corresponds to an electrical length of one-half wave length(10). If the distance to the point of reflection is D , then

$$D = a\lambda_1 = \frac{aV_1}{f_1} \quad (136)$$

where a = a constant

λ_1 = wave length corresponding to f_1

f_1 = first frequency

V_1 = velocity of propagation along the transmission line

If the second frequency at which maximum voltage was observed is f_2 , then

$$D = \left(a + \frac{1}{2}\right)\lambda_2 = \left(c + \frac{1}{2}\right)\frac{V_2}{f_2} \quad (137)$$

In this equation a second velocity of propagation for the second frequency is written as V_2 . Substituting Eq. (136) in Eq. (137),

$$D = \left(\frac{Df_1}{V_1} + \frac{1}{2}\right)\frac{V_2}{f_2} \quad (138)$$

Solving for D in terms of both frequencies

$$D = \frac{V_1 V_2}{2(V_1 f_2 - V_2 f_1)} \quad (139)$$

For air, V_1 and V_2 will be equal to each other and equal to c , the velocity of radio waves in space; therefore

$$D = \frac{c}{2(f_2 - f_1)} \quad (140)$$

This equation means, then, that if two arithmetically successive frequencies are known for which the voltages present at the terminals are the same, the length of the transmission line (or the space from airplane to ground) may be calculated.

Suppose that the difference between these "measuring" frequencies is allowed to remain the same for any value of line distance equal to nD , then,

$$nD = \frac{0.5c}{f_a/n} \quad (141)$$

where f_a is the difference frequency equal to $f_2 - f_1$.

This expression means that only one n th of the previous frequency difference is required to measure a distance n times the length of that previously measured. Or, in other words, for the same frequency difference, there will be n times more voltage peaks at the generator terminals.

For a known frequency difference, then, it is possible to know the distance merely by sweeping the voltage generator between two known frequencies and counting the number of times that a terminal voltmeter is observed to rise to a maximum. Another method for making this determination is to sweep between the two frequencies in a given time interval and measure the frequency of the energy pulses occasioned by the voltage rise. This latter principle is the method actually employed.

The Weco Altimeter.—This device(11) consists of six major units. A transmitter delivers about 10 watts to a dipole antenna located below one wing of the airplane and is frequency modulated between 410 and 445 megacycles. This modulation is accomplished at a rate of 60 cycles per second. The energy from the transmitting antenna strikes the ground and is reflected

back to the airplane where it is received by an antenna connected to a receiver. The receiver and transmitter are shielded from each other, and the antennas are arranged for minimum coupling; however, a certain amount of energy from the transmitting antenna reaches the receiving antenna and, hence, adds and subtracts to the reflected energy in the manner discussed for the transmission line. The rectified output of the receiver increases and decreases at a frequency which is a function of the distance from the airplane to the ground. Incorporated in the receiver is an electronic frequency meter. This is really a rate-of-

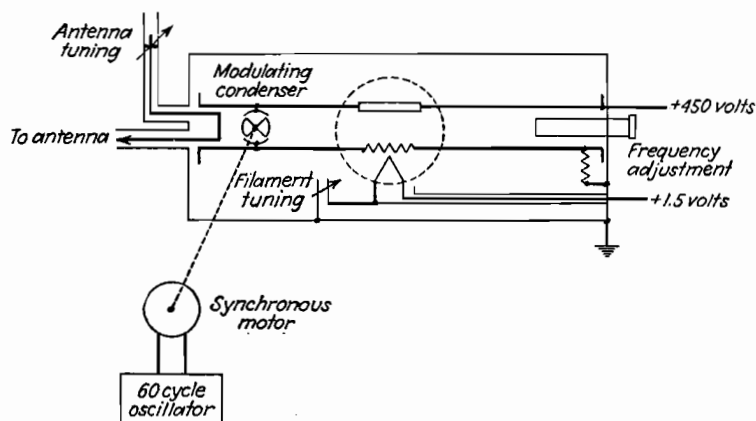

FIG. 141.—Schematic of transmitter used with the Western Electric radio altimeter. (Courtesy of Western Electric Company.)

energy pulse counter with an indicating milliammeter which is calibrated to read zero to 5,000 ft. In order to increase the accuracy of the readings, the scale of the meter extends over a range of 270 deg. The first 1,000 ft. are on an expanded portion of the scale, and the smallest division represents 10 ft.

It is necessary to provide certain apparatus for supplying proper voltage and current to the plate and filament of the transmitter tube and to the plates of the receiving tubes, so all equipment of this type is assembled on a single chassis and constitutes the sixth unit of this altimeter.

Weco Transmitter.—The transmitter(12) consists of a special oscillator in which are incorporated a set of Lecher wires and a special triode tube. This tube has interelectrode capacities not exceeding $1.5 \mu\text{f}$. This oscillator has only a single tube, and

its frequency stability is said to be plus or minus 1 per cent. It is capable of being tuned to any carrier frequency between 410 and 445 megacycles. This tube requires 450 volts at about 90 to 110 milliamp. In the same chassis with the oscillator just described is located a second oscillator operating at a frequency of 60 cycles per second. This oscillator is connected to a synchronous motor driving the rotor of a small variable condenser which is located at the center of one pair of Lecher wires. The resulting wave emitted from the transmitter is saw-toothed in nature and varies at a rate of 60 cycles per second between 410

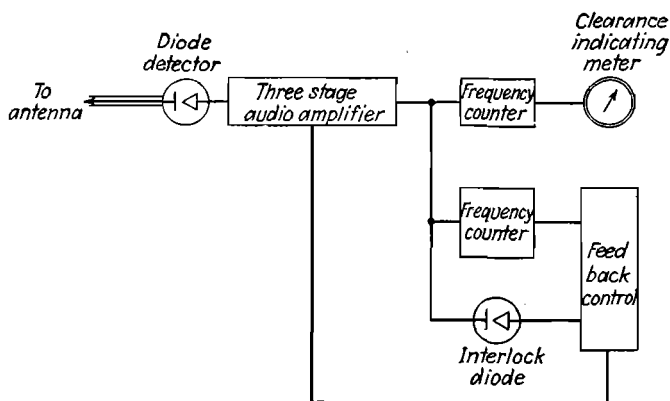

FIG. 142.—Block diagram of receiver used with the Western Electric altimeter. (Courtesy of Western Electric Company.)

to 445 megacycles. A requirement of this transmitter is that it always emit the same field strength regardless of frequency. At a frequency of 432 megacycles the frequency modulation represents a deviation of plus or minus $2\frac{1}{2}$ per cent. From the theoretical considerations previously discussed, it can be seen that in order to read the same minimum altitude the same deviation of 12.5 megacycles would be necessary at any carrier frequency. It is evident that such a frequency variation at a rapid cyclic rate and with uniform power output would be impossible at frequencies less than 100 megacycles. As a practical problem, the carrier frequency used is none too high to allow uniform output over the frequency range swept by the condenser.

A diagram of the transmitter is shown in Fig. 141.

Receiver.—The radio-frequency portion of the receiver is simple, consisting only of a diode detector. From this point on, the

circuits handling the resulting audio frequencies are rather unusual. With the system used, the resulting audio frequency varies at a rate of about 6 cycles per foot. This means that at an elevation of 5,000 ft. aboveground the audio system must accept 30,000 cycles. At higher altitudes the meter need not indicate accurately, but it must remain at an indication of 5,000 ft. in order not to confuse the observer. A block diagram of the receiver is shown in Fig. 142. By referring to this diagram, it can be seen that the diode detector is followed by three high-gain stages of audio-frequency amplification and two frequency-

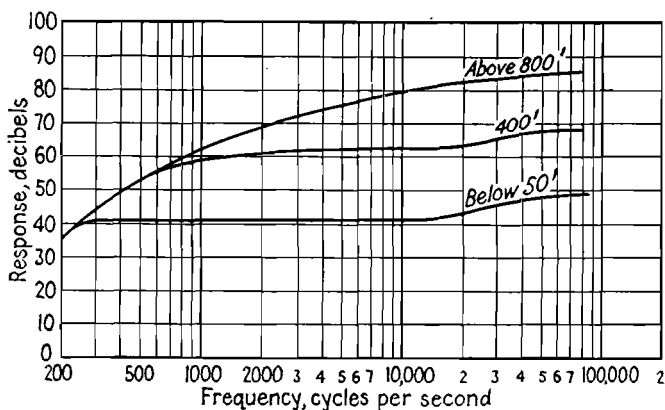

Fig. 143.—Variation in audio frequency response with altitude of the Western Electric altimeter. (Courtesy of Western Electric Company.)

counter circuits. One of these circuits indicates on the altitude meter while the second is used to control feedback to the audio amplifier in such a manner as to alter the frequency and gain characteristics of the audio stage.

Extremely effective gain control is necessary because the signal strength varies widely with the distance of the airplane above the terrain. The characteristics of the receiver are shown in Fig. 143. It can be seen that the gain of the audio amplifier is made to vary from 38 to 85 db. At low elevations the gain is reduced at high frequencies in order to avoid the amplification of the higher order harmonics. At high elevations the resultant frequency is high and the signal strength is low, so the gain of the receiver for the higher frequencies is increased. By employing these characteristics the signal-to-noise ratio is improved at high elevations because unnecessary

frequencies are not amplified. Since this feedback is a function of frequency, a momentary loss of signal at high elevations would cause the feedback to cease, thus returning the receiver to the characteristics marked "below 50 ft." on Fig. 143, causing the elevation meter to read zero. In order to prevent this possibility, an additional circuit is added in parallel with the frequency counters. This circuit disables the feedback in the event that the signal is lost momentarily. Nine tubes and four voltage regulators are used in the receiver.

Power Unit.—The peculiar characteristics of the tube used in the transmitter make necessary a constant filament current of 9 amp. at only 1.5 volts. This filament power is supplied via six ballast lamps connected in series parallel and located in the power unit.

When primary voltage is supplied to the power unit, the receiver and the 60-cycle oscillator in the transmitter receive power but the microwave oscillator and the dynamotor do not. This characteristic is attained by using a relay connected so that it short-circuits the filaments and opens the dynamotor primary circuit. After the ballast lamps have reached their normal temperatures (in about 30 sec.), the missing voltages are supplied by pressing a button. All the plate voltages required for the receiver are supplied from the 450-volt dynamotor located in the power unit. The proper voltage dividers are, however, located in the receiver.

Antennas.—Antennas are, generally speaking, single-frequency devices; however, the antennas used with this instrument must operate over a range of frequencies. The efficiency of an antenna is not necessarily impaired by changing the frequency if the impedance of the generator connected to it is also changed. The antenna developed is a form of dipole; however, one half of it has a transmission-line transformer arrangement over one of the conductors. This arrangement serves to hold the impedance of the antennas reasonably constant. The antennas are in the form of a T structure. The vertical portion of the T is about 7 in. and the "cross" is 14 in. The antennas were intended to be mounted about one-quarter wave length from the skin of the airplane, and thus allow it to act as a reflector and produce gain.

The leg of the T forms a concentric transmission line with the inner conductor, as shown in Fig. 144. A plastic cover

is placed over the cross on the T in order to prevent precipitation from affecting the antenna performance. A later development consisted in constructing parabolic reflectors in the wing of the airplane, and antennas of the type described above were mounted within these reflectors. The faces of the reflectors were covered with a plastic sheet, and in this manner the aerodynamic drag was reduced to zero.

Testing the Altimeter.—A special unit was designed to provide a means for testing the altimeter without the necessity of a flight. In this unit are mounted two meters for reading currents, a fre-

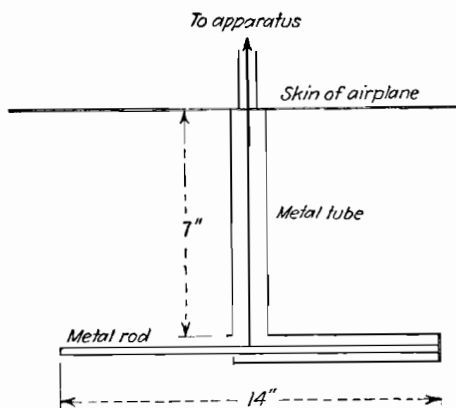

FIG. 144.—Antenna used with Western Electric altimeter. (Courtesy of Western Electric Company.)

quency meter for measuring the frequency of the radio amplifier, a cathode-ray oscilloscope, and a 24,000-cycle audio oscillator. Adjustment of the transmitter consists in checking the radio frequency and adjusting the transmitter so that uniform power is delivered as the frequency is changed. The adjustment for the receiver consists in aligning it for maximum response and calibrating the frequency counter.

Performance.—The Western Electric Absolute Radio Altimeter is capable of reading distances from 20 to 5,000 ft. From 5,000 to 15,000 ft. the needle rests against the 5,000-ft. mark. Above 15,000 ft. the readings are somewhat less than 5,000 ft. The claimed accuracy within the 5,000-ft. limit is about 10 per cent. Deviation from absolute accuracy is caused by variations in the amount of frequency change, errors in the audio-frequency

counter circuit, and errors in the instrument used to read elevation. Since this accuracy is on a percentage basis, its actual value increases for low altitudes and makes the device useful as an instrument landing check.

The weights of the major apparatus units are as follows:

	Pounds
Transmitter.....	13.9
Receiver.....	9.56
Power unit.....	15
Meter.....	1.25
Two antennas.....	3.4
Total.....	<u>43.11</u>

The weight performance is about 116 ft. per pound. To this weight must be added that of the transmission lines, mounting rack, and other incidentals common to all aircraft installations of radio apparatus. The total weight installed is about 60 lb.

One of the biggest objections to this device is the peculiar characteristics of the microwave oscillator tube filament. The low-voltage filament makes necessary a large power loss. This apparatus takes a total drain of 25.2 amp. from an airplane's 12-volt supply. The usual generator on the airplane has a capacity of 50 amp.; thus, if installed, the altimeter would use one half the power available from one generator. If the tube could be changed to one with a more conventional oscillator filament, this drain would be reduced by about 8 amp.

Aside from the characteristic listed above, one of the objections to the device lies in its lack of a minimum altitude indicator. A pilot can hardly be expected to eye the meter continually as he flies along the airways, but would do this only for certain maneuvers. If he felt he knew his position accurately, the meter probably would not be consulted. This device, to be useful as an airways warning instrument, should be equipped with a light, buzzer, or other indicator that would warn when elevations of 1,000 ft. or less have been passed; also, another device to indicate elevations of less than 500 ft. might be desirable. This altimeter unfortunately does not include these features. In the experimental models, sensitive current relays were used to provide this warning, but they did not operate successfully because of their susceptibility to vibration.

Problems

1. A sonic altimeter calibrated to read for vertical distance is installed on an airplane that is traveling at a speed of 120 m.p.h., 500 ft. above the earth. The sound generator and detector are spaced 50 ft. from each other. What is the resulting altitude error?

2. What will be the sound pressure received by a sound detector installed in an airplane flying at an altitude of 250 ft., if the sound generator produces 25 watts of sound power into a cone having an angle of 20 deg. and a vertical axis?

3. A capacity altimeter has two electrodes consisting of No. 14 A.W.G. wire mounted 10 in. from the surface of an all-metal airplane. When the airplane is resting on the ground, the wires are inclined at an angle of 20 deg. (from the horizontal) and with their centers 3 ft. from the ground. Calculate the capacity of the wires to each other, to the skin of the airplane, and to ground when the airplane is on the ground and when it is at an elevation of 50 ft. above ground.

4. A radio altimeter is intended to measure accurately an elevation of 30,000 ft. aboveground, but the frequency counter will not accept more than 50,000 cycles or less than 100 cycles. What is the minimum altitude that can be indicated on this device? What is the required frequency variation?

Bibliography

1. DRAPER, C. S.: *The Sonic Altimeter*, N.A.C.A. Tech. Notes, 611, August, 1937.
2. Radio Instrument and Measurements, *Bur. Standards Circ.* 74, 2d ed., p. 237, March, 1924.
3. HYLAND, L. A.: True Altitude Meters, *Aviation*, Oct. 27, 1928, p. 1322.
4. GUNN, ROSS: Device for Indicating Small Changes of Capacity, U.S. Patent No. 1,701,975, Feb. 12, 1929.
5. Radio Altimeters, *Science and Invention*, Vol. 16, No. 10, pp. 952-953, February, 1929.
6. ALEXANDERSON, ERNEST F. W.: Method and Means for Indicating Altitude from Aircraft, U.S. Patent No. 1,913,148, June 6, 1933.
7. Solving the Problem of Fog Flying, Daniel Guggenheim Fund for the Promotion of Aeronautics, p. 29, 1929.
8. ESPENSCHIED, LLOYD: Method and Means for Measuring Altitude of Aircraft, U.S. Patent No. 2,045,072, June 23, 1936.
9. ROBERTS, HENRY W.: The Absolute Altimeter, *Aero Digest*, November, 1938, p. 87.
10. EVERITT, W. L.: "Communication Engineering," p. 131, McGraw-Hill Book Company, Inc., New York, 1932.
11. ESPENSCHIED, LLOYD, and R. C. NEWHOUSE: A Terrain Clearance Indicator, *Bell System Tech. Jour.*, Vol. 18, No. 1, p. 222, January, 1939.
12. Radio Altimeter Equipment (1B), *Western Electric Instruction Bull.* 961P.

CHAPTER VIII

DIRECTION FINDING FROM GROUND STATIONS

When the problem of radio aviation was first considered by Europeans, the airplanes in common use were of the cabin type controlled by more than a single pilot, so the method evolved closely followed the system that had been previously used for boats. A radio operator, or another operator similarly qualified, was carried on the airplane. The pilot wrote out a message asking for a bearing and gave it to this operator. The radio operator, using a hand reel, released a long trailing wire antenna and using telegraphy on long waves asked for bearings from stations on the ground. These bearings were in turn transmitted to the airplane by telegraphy, copied by the radio operator, and handed to the pilot. Such a system was, however, untenable for the United States. The airplanes in service were chiefly used for carrying mail and were manned by a single pilot. The provision for carrying even a single passenger was a later innovation. It seemed, then, that a radio system must be automatic so that the pilot could use it without reference to calculation. The radio-range system was evolved, and this facility made use of the long waves because these had the propagation characteristics best suited to directional guidance. Telephony was used for communication, and this was accomplished at the medium-high frequencies, or ionosphere-propagated wave lengths. The use of these frequencies was logical because they permit signals from low-power transmitters to be heard at great distances. Further, a practical aircraft antenna for these frequencies, having reasonable efficiency, could be constructed. It was not intended that this communication system be used for directional control, so no further thought was given to the frequencies employed. They seemed admirably suited to the problem at hand. Later, however, the ability of ground personnel to learn the position of the airplane independently was considered important. This came about both from certain experiences and from changes in air transport operating. One of these experiences concerns a pilot

in an airplane not oxygen equipped who flew higher and higher to climb above an overcast. The storm area, however, extended to such a high altitude that the oxygen supply in the air above it was insufficient, and the pilot suffering from oxygen starvation could no longer think clearly. Only by instructions from the ground was he able to make a safe landing. Other occurrences leading to the desire for bearings from the ground were cases where the pilots became lost owing to various circumstances and narrowly escaped accident. The other factor came about in the departure from the practice of having pilots assume full responsibility for the trip and sharing this responsibility with a dispatcher on the ground. If the ground dispatcher himself could determine the position of the airplane this responsibility could be better shared.

It is true that numerous other devices are placed on the airplane to enable safe aviation by the pilot, but because of the factor last discussed, the demand for ground equipment has never been greater.

With the foregoing uses in mind it is possible to determine the requirements for a ground-station direction finder. First, since this device is not intended as a primary source of avigational information, its accuracy need not be extremely high. However, it will be called upon to furnish bearings in an emergency when the results obtained with the other aids are under suspicion, so it must at no time give as true, highly inaccurate bearings. If such bearings are occasionally produced, they must have attendant characteristics that will allow the operators of the device to recognize them instantly as fallacious.

The ionosphere-propagated waves behave erratically during their period of propagation, and direction finding with them involves many considerations not common with the devices previously discussed. It is to be understood, then, that this chapter deals with direction finding from the ground, only on those waves lying in the frequency range from 2,000 to 30,000 kc.; that is, those waves which make use of the ionosphere (Kennelly-Heaviside and Appleton layers) as a means for their propagation from transmitter to receiver.

The propagation of these waves will be discussed in greater detail and from the engineering approach later in this chapter, but for the present a crude analogy to illustrate the problem

faced will be pictured. Light waves, like radio waves, are electromagnetic waves, so light phenomena may be used to illustrate the principles involved. If one glances at a light coming from a lamp across the room, he will have no difficulty in pointing to the source of this light because, like long radio waves, this light comes directly to the observer. Medium-short waves, however, are absorbed by the ground after they have traveled the comparatively short distance of about 30 miles. This can be represented in the analogy by placing an opaque screen between the observer and the lamp, a short distance from the lamp. Medium-high-frequency radio waves travel phenomenally long distances by use of ionized layers located from 110 to 300 km. above the surface of the earth. The radio waves strike these layers and are reflected to the ground at the receiving terminal with but slight attenuation (under suitable conditions). In the analogy this may be represented by placing a mirror on the ceiling above the lamp. It is now more difficult for the observer to determine the location of the source of the light. This problem could still be easily solved if the reflecting layers were as fixed as a hard-surfaced mirror; however, this is not the case. The layers are composed of ionized gas, the ionization of which varies with the many cosmic forces acting on it. These layers are more like the surface of the ocean, which tosses and pitches with the wind and the tide. This can be simulated by having the mirror suspended by elastic and then attaching to it a cord that is pulled at irregular intervals by a suitable mechanism. It is now virtually impossible for the observer to determine accurately the source of the light.

Characteristics of Waves Received from the Ionosphere.—In the foregoing paragraphs ionosphere-propagated waves were discussed in terms of analogies used to present the problem of ground direction finding for aeronautics, but more accurate consideration of the characteristics of these waves is necessary in order to understand the requirement of apparatus to be used for performing this direction-finding function. As the radio wave leaves the transmitting antenna to travel outward through space but along the surface of the earth, it is composed of an electric and a magnetic field. These fields are in space quadrature but in time phase with each other. Not only is this true, but there is a fixed relation that applies between the strength of the electric

and magnetic field at any time. This normal wave is said to be vertically polarized; that is, the electric field is vertical and the magnetic field is horizontal. This must be the case; otherwise the conducting earth would short-circuit and hence wipe out the electrostatic flux of a horizontally polarized wave. It is this wave that has been considered in the previous discussion of long-wave radio ranges and aircraft direction finders. For medium-high frequencies, however, the absorption of even this normally polarized wave is very severe, and at distances of 15 to 100 miles (depending on frequency) their signal strengths have weakened beyond the usable point. As the wave leaves the antenna, however, it not only radiates outward along the surface of the earth but it also radiates upward (unless special suppressing antennas are used), and in its travels it strikes ionized gas layers. The characteristics of these layers will be discussed later. It is sufficient to know for this discussion that the wave is refracted, reflected, or both, and returns to earth at distances from 30 miles to thousands of miles with astonishingly great signal strengths. During this process, however, the wave undergoes alterations that greatly increase the difficulty of locating the direction of its origin as compared with the same process for the ground wave.

Polarization.—One of the most important changes in so far as direction finding is concerned is the change in polarization. It is theorized that the electrostatic field of the waves(1) exerts forces on the ions and electrons of the gas layers and causes them to vibrate. Since a moving charge is an electric current, the effect is similar to that of reradiation from a parasitically excited antenna. Because of the inertia of the electrons and ions, the velocity and displacement lag 90 deg. behind the intensity of the exciting field. Further, the electrons are acted upon by the earth's magnetic field; hence, the movement follows an elliptical path. It is this motion along the minor axis that is said to cause a component polarized at 90 deg. with respect to the polarization of the exciting wave. Namba(2), Iso and Ueno studying the polarization of these waves found them to be elliptically polarized; however, for short distances the major component was horizontal, whereas at longer distances the major component was vertical. The ratio of the major to minor component was from 10 to 30. Since the waves traveling the greater distances strike the earth at low-incidence angles, it may

be that their polarization is rotated back to normal by the effects of the earth's conductivity.

It was previously stated that for waves that travel along the surface of the earth, the relation between the electrostatic and electromagnetic field was fixed because of the electromagnetic energy per unit of space, but this no longer is true for elliptically polarized waves. The electric and magnetic components continue to be contained in the same plane perpendicular to the direction of propagation of the wave. Further, the time phase remains the same and the space phase remains in quadra-

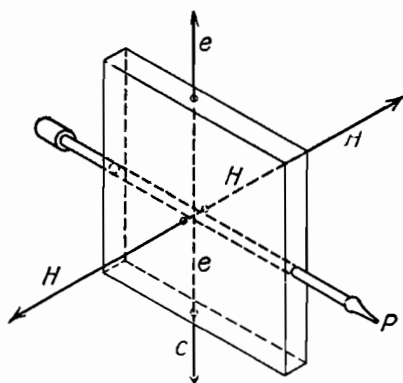

FIG. 145.—Positions of the electric and magnetic vectors in a normally polarized wave. The direction of propagation is indicated by P .

ture for the two components, but the two fields have rotated so that they are at some angle to the plane of polarization. A pictorial representation of this change is shown in Figs. 145 and 146. In Fig. 145 is shown the direction of propagation P contained in the vertical plane of propagation. In this same plane, but at right angles to the direction of propagation, is the electric field e . At right angles to both the plane and the direction of propagation is the magnetic field H . Figure 145, then, represents the conditions existing with a normally polarized wave. In Fig. 146 the polarization is no longer normal. The electric field has rotated clockwise about the direction of propagation. The magnetic field has also rotated so that it continues to bear its 90-deg. relation with the electric field. It is possible, of course, to resolve the electric field into a component occupying

the position held by the electric field prior to the modification of the polarization and a component that occupies the position held by the magnetic field during normal polarization.

Fading.—With the normal transmitting equipment, the wave leaves the transmitting antenna with a given intensity, and when only the ground wave is received, it has a constant value of intensity with time except for small variations and those purposely imposed on the wave in the form of modulation. This is not true for the wave received from the ionosphere. On the contrary, the intensity of these signals continually changes.

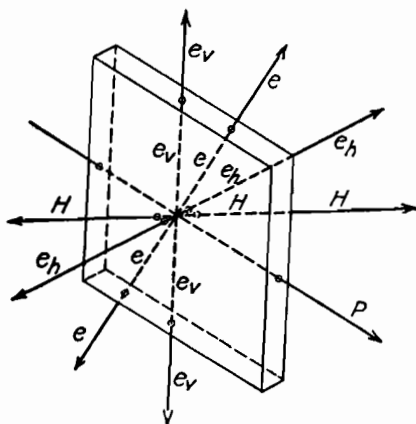

FIG. 146.—Rotation of the electric and magnetic vectors in an abnormally polarized wave.

Observers(3, 5) who have made a study of this phenomenon report fading rates from zero to 100 per second. There seem to be various types of fading. One type has been found to remain at about one fade every 5 sec. When this phenomenon was first encountered, it was new to radio engineers, and so it was the subject of much conjecture. One of the first theories evolved gave as the cause interference between the sky and ground wave. This theory did not hold for long because it was soon learned that no ground wave was present during much of the reception from the ionosphere. One author(4) gives as a reason interference between two rays. The presence of these rays is attributed to the earth's magnetic field which causes the upper atmosphere to show double refraction. The change

in the phase of these two rays is large for only small changes in the strength of the earth's field. Calculation shows a 30-deg. change for a variation in magnetic field intensity of only 0.00015 gauss, and this change in phase would be sufficient to cause the signal strength to vary from maximum to zero intensity. There seems to be no doubt but that there are two or more rays present and that slight changes in path, caused perhaps by the variation in ionizing force from the sun, may readily cause the various rays to add together or subtract. Another factor suggested as contributing to the fading condition is the variation in absorption of the refracting layers. This absorption is again caused by variation in the number of electrons and ions present as a function of the variation in the ionizing forces.

Path Deviation.—Waves propagated directly from the transmitting antenna to the receiver travel a great circle path. It was the early discovery of this principle that led to the development of radio direction finders. Early in the development of the art, however, there was some suspicion that this was not always the case. The subsequent investigations proved that these supposed deviations were caused by failure of the equipment when used with abnormally polarized waves. With improvement in apparatus, these investigations continued, and the best measurements of these deviations have taken place within the last two or three years. Barfield(6), using a spaced loop direction finder, together with a photographed cathode-ray tube, on stations located at distances up to 5,000 km. found deviations of "10 or 20 deg.," although his tests showed that there were no occasions when steady deviations of more than 1 or 2 deg. persisted throughout the entire group of observations. Feldman(7), making observations with a multiple-unit steerable directive-antenna array, found two rays, one of which deviated from the great circle path by as much as 35 deg. Deviations of 10 to 20 deg. were common, although it is possible that the larger deviations observed may have been due to the phenomenon of "scattering" to be discussed later. These deviations were also noticed by Smith-Rose at Slough using a special Adcock direction finder and by the measurements made by the Mackay Radio Company. The causes of these deviations have not been definitely established but they are, no doubt, linked with the changing structure of the ionized layer as well as by auroral

activity. From all the data obtained it seems evident that deviations in direct transmission from the great circle path are, in general, less than 20 deg. and are probably of short duration.

Scattering.—In many deviation studies there are reports of abnormally large bearing errors. Barfield(6) reports discrepancies of as much as 50 deg. on near-by stations. These large deviations are all observed within the skip zone and are to be differentiated from those found beyond this zone. Since the skip zone is generally regarded as that area where the signals from the ionized layers do not reach the earth, the statement that signals received within this area have errors seems incompatible with the previous concept. Actually, however, there is a signal heard within this area caused by reflection from the higher layers, although it is often too weak to be suitable for consistent communication.

Signals so received are designated as having been the result of "scattering." These types of signals were studied in 1928 and reported by Taylor(8) and Young and are often designated as "echoes" because they make their appearance 1 to 50 milliseec. after the time that the direct wave should be received. These early observers were puzzled to note that much greater periods of time were required for the reception of near-by stations (probably within the skip zone) than by stations thousands of miles away. Eckersley(9), studying this phenomenon from the standpoint of direction finding, evolved the theory that these signals result from the direct ray striking areas that reflect back the energy. Since these areas, or (to use Eckersley's designation) "points," are located all around the receiver, the radiation can come from any of them and, hence, exhibits no directional characteristic whatsoever. He also noted that unless a powerful transmitted signal was used the presence of these scattered signals could not be detected. Further, it was noticed that definite directional characteristics were present, if the transmission was accomplished with a beam (directive) antenna, although the direction was often extremely erroneous. This is explained by points of reflection located along the path of the beam.

A recent study by Edwards(10) and Jansky was made in connection with reception of directive transmission. This study covered both the vertical and horizontal directivity as well as

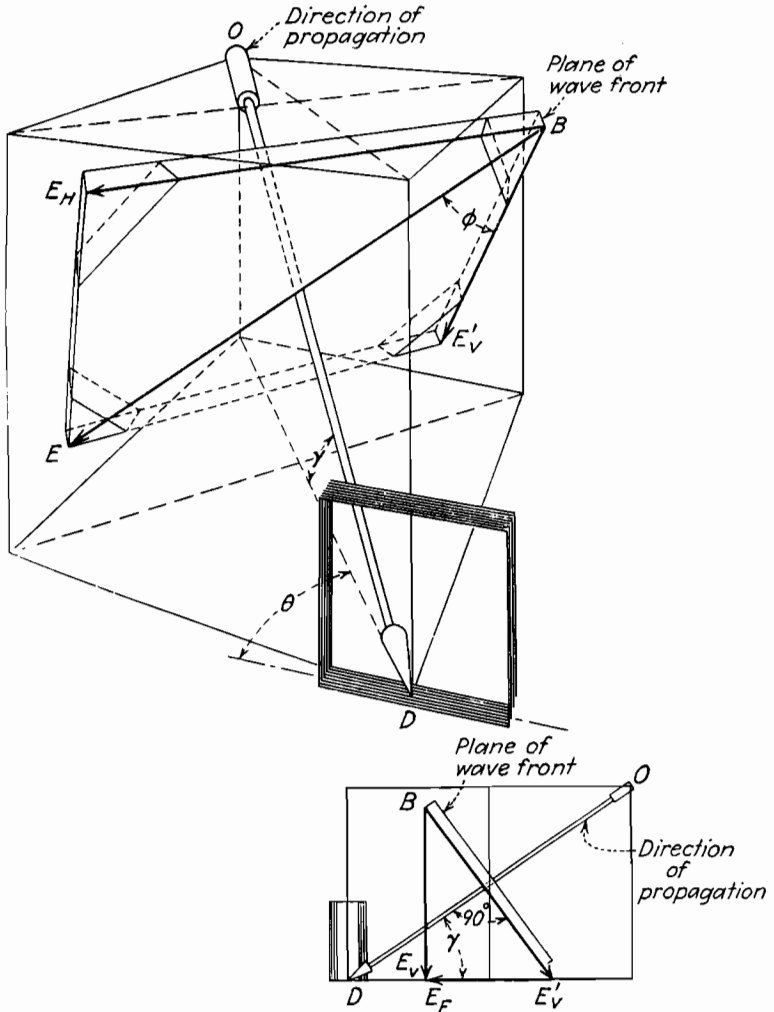

FIG. 147.—Abnormally polarized wave arriving at a direction finder from the ionosphere. The electric field, EB , is resolved into two components, E_HB and $E'VB$, in the plane of the wave front. The component $E'VB$ is further resolved into two components, E_F and E_V . The component, E_F , is horizontal and in the direction of propagation. The component, E_V , is vertical.

the time factor. Since large directive arrays with high gain values were involved, the presence of these "echo" signals was very predominant. In these studies three types of echoes were noticed and classified as "multiple," "random," and "sharp." Echoes of the multiple type are those in which succeeding echoes have delays that are approximate multiples of the first. With the random echoes the direction of arrival is not closely associated with that of the transmitted beam. Sharp echoes have low amplitudes and short time delays.

Edwards and Jansky conclude that "random" echoes are caused by scattering from sporadic ionosphere regions, or "clouds." Their findings further indicate that multiple echoes are produced by reflections from roughness in the earth's surface, and the presence of the sharp echoes was not explained. Bearing deviations in excess of 20 deg. were found to characterize the random echo.

In order that rough surfaces can act as regular reflectors, the following equation must be satisfied:

$$\frac{2H}{\lambda} \sin \delta \ll 1 \quad (142)$$

where H = difference in elevation

λ = wave length

δ = angle of incidence measured from the surface to the impinging ray

It can thus be seen that as the incident angle becomes small, conditions favoring regular reflection improve and those for scattering become less. That is to say, scattering is more likely to be present at a distance close to the transmitting station.

The characteristics of radio transmission received from the ionosphere having been described, the effects of these upon direction-finding equipment will now be discussed.

Effect of Horizontal Polarization on Loop Direction Finders.—

In Fig. 147 is shown a line OD which represents the direction of propagation of an abnormally polarized wave. The electric field of this wave is in the direction EB . This field can be resolved into one vertical and two horizontal components. These are

$$E_H = E \sin \phi \quad (143)$$

$$E_v = E \cos \phi \cos \gamma \quad (144)$$

$$E_f = E \cos \phi \sin \gamma \quad (145)$$

where ϕ is the angle of polarization and γ the incident angle. With time, the vertical component propagates toward the reader while the horizontal components move downward. Coinciding with the vertical projection of the direction of propagation is the vertical axis of a square loop antenna. The angle between the plane of the loop and the horizontal projection of the direction of propagation is θ . The loop is rotated for direction finding until a minimum signal is heard, and the value of θ required to produce this minimum signal is then observed. If the horizontal component of the wave is neglected, it can be seen that the conditions exactly follow those discussed in Chap. IV, and the resulting equation for the received voltage will be

$$E_L = E_v K \cos \theta \quad (146)$$

where E_L is the resulting loop voltage and K is a constant dependent on the structure of the loop, the wave length of the received signals, etc. Under the foregoing conditions it can be seen that the voltage output of the loop is a minimum when the angle θ equals 90 deg., that is, when the plane of the loop antenna is at right angles to the direction of the oncoming wave.

If now the vertical component is neglected and the reaction of the loop to the horizontal components is studied with the loop in a position for minimum reception of the vertical component, it will be seen that the conditions are exactly as they were except that the horizontal angle θ has been replaced by the vertical angle γ . The pickup of the loop, however, is maximum when its plane is parallel to any field component and minimum when at right angles to this component; hence the following equation may be written:

$$E'_L = KE_H \sin \gamma \sin \theta \quad (147)$$

For a given vertical angle, the value of $\sin \gamma$ is constant. It can be seen that minimum reception from the horizontal component at right angles to the horizontal projection of the direction of propagation occurs when θ is zero. Reception of the horizontal component in line with the horizontal projection of the direction of propagation is exactly the same as for the previous

horizontal component except that the latter, being at right angles to the former, will necessarily change $\sin \theta$ to $\cos \theta$ or

$$E''_L = KE_F \sin \gamma \cos \theta \quad (148)$$

It follows, therefore, that a null taken on this component of the radio field will coincide with that taken on the vertical field. The complete voltage induced at any one time from all components is

$$E'''_L = E_L + E'_L + E''_L \quad (149)$$

$$E'''_L = E_V K' \cos \theta + E_H K'' \sin \gamma \sin \theta + E_F K''' \sin \gamma \cos \theta \quad (149a)$$

$$E'''_L = EK''''(\cos \phi \cos \gamma \cos \theta + \sin \phi \sin \gamma \sin \theta + \cos \phi \sin^2 \gamma \cos \theta) \quad (150)$$

From this expression it can be seen that unless the angle of polarization is zero (normal) it will never be possible to obtain a true null signal, but the minimum signal will occur for some angle of the loop that will be a function of the angle of polarization. The loop antenna is, then, clearly useless as a direction finder to be used with ionosphere-propagated waves in that it no longer produces a null in the presence of one of the peculiarities of this type of reception. It is possible also from the foregoing discussion to draw a second conclusion, namely, that in order for a direction finder to give true bearings in the presence of abnormally polarized waves it must be unaffected by the horizontal component of the wave.

The Adcock Direction Finder.—In 1919, an English patent(15) was granted to Adcock for a direction-finder antenna system having for its purpose the elimination of polarization error. Fundamentally, the principle behind the system was the use of elements sensitive only to the vertically polarized component of the radio wave and completely insensitive to the horizontal component. Various forms(12) of this antenna system are shown in Fig. 148. In this figure the antenna shown under (A) is the original or *U*-type form. The other forms shown are modifications added by later inventors for the purpose of reducing the system's sensitivity to the horizontally polarized component of the radio wave.

The theory of the space pattern of a loop antenna has previously been discussed assuming vertically polarized waves,

and this same theory applies to the Adcock antenna. If the space between elements is small compared with the wave length of the received signal, the following equation will hold:

$$E_A = E_V K' \cos \theta \quad (151)$$

In this equation, E_A is the resulting voltage induced in the Adcock system, E_V the vertical component of the radio field, K' a constant dependent on the effective height of the antenna, and θ the angle between the vertical plane containing the two

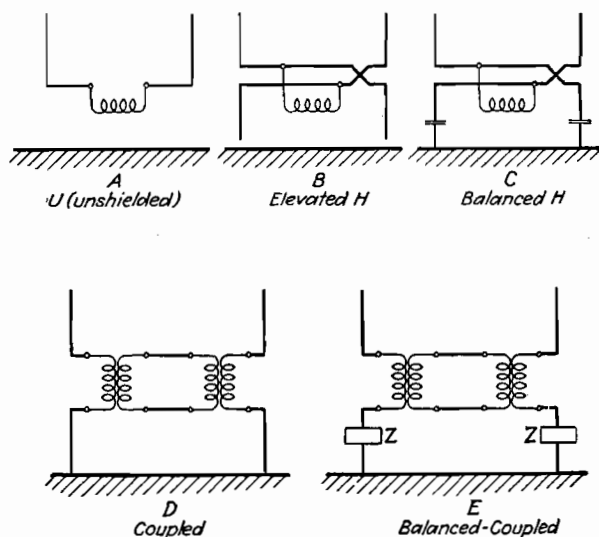

FIG. 148.—Various forms of Adcock antenna systems.

elements of the Adcock and the plane of polarization of the radio wave. If the spacing between elements is great compared with the wave length, the deviation of the actual field pattern from that given by Eq. (151) may be as great as 6 per cent, provided that this spacing does not exceed one-half wave length(11). If the spacing is greater than one-half wave length, the field pattern may greatly violate this equation and even produce a four-lobed pattern rather than the clover leaf. In all the discussion on Adcock antennas it will be assumed that the field pattern (as far as vertically polarized waves are concerned) follows Eq. (151), thereby producing the familiar figure-8 pattern consisting of two tangential circles.

For an abnormally polarized wave, assuming that the system not sensitive to the horizontal component, Eq. (144) may be substituted in (151):

$$E_A = EK' \cos \theta \cos \phi \cos \gamma \quad (152)$$

Another factor must be considered in writing the complete equation for the Adcock system. It was seen in the discussion for the loop that the voltage output was proportional (within the limits previously discussed) to the spacing between the sides of the loop, or in this case between the two vertical antennas.

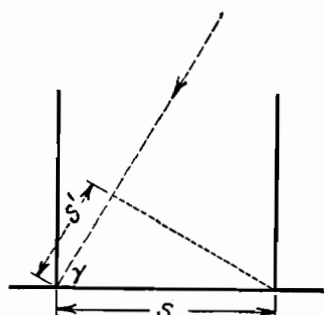

FIG. 149.—When the radio wave arrives at an angle greater than grazing incidence, the effective spacing between Adcock elements is reduced from S to S' .

Referring to Fig. 149 it can be seen that for waves arriving at an angle to the ground the effective distance between the elements is reduced and is now S' rather than S . This spacing entered into the factor K' of Eq. (151); hence,

$$S' = S \cos \gamma \quad (153)$$

or

$$E_A = EKS \cos \theta \cos \phi \cos^2 \gamma \quad (154)$$

From this equation it can be seen that it is possible to obtain a null (by varying θ) regardless of the incident and polarization angles. It must be pointed out, however, that for certain values of these angles the induced voltage may be very small, and hence it may not be possible to secure a satisfactory null.

In Fig. 148 the antennas are shown connected to coils which are presumably connected to receivers. In a common form of direction finder using the Adcock antennas these coils are a portion of a goniometer. The goniometer was adopted from the Bellini-Tosi loop system and has previously been mentioned in connection with the radio range. When the goniometer is used, two pairs of Adcock antennas are employed. They are so located that the vertical planes containing them are at right angles to each other. Each antenna pair connects to one coil of the goniometer field as shown in Fig. 150. From Figs. 151 and 152, and from previous discussions, the currents in antennas AA'

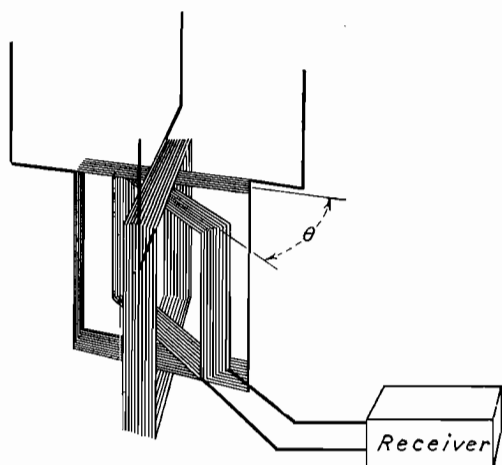

FIG. 150.—Mechanical structure of a goniometer used for direction finding and its method of connection. The coils connecting to the antennas are fixed and bear a 90-deg. relation to each other. The inner coil rotates.

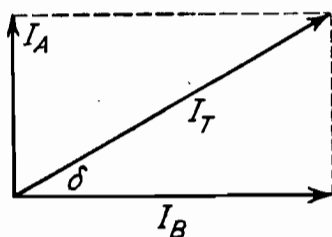

FIG. 151.

FIG. 151.—Addition of vectors representing the currents and hence the fields of the fixed goniometer coils. The resulting current (and hence field) makes an angle δ with respect to one current.

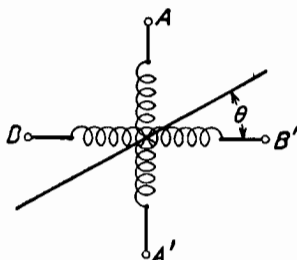

FIG. 152.

FIG. 152.—Position of the field resulting from vectorial addition. The angle θ corresponds to δ of Fig. 151.

and BB' and hence in the respective goniometer field coils can be written as

$$I_A = I_{\max} \cos \theta \tag{155a}$$

$$\begin{aligned} I_B &= I_{\max} \cos (90^\circ - \theta) \\ &= I_{\max} \sin \theta \end{aligned} \tag{155b}$$

θ is the angle between the plane containing one pair of antennas and the plane of propagation of the radio wave. The resultant flux in the goniometer will be the vector sum of the flux pro-

duced by each field coil. Since this flux is proportional to the current in the coils, the flux resultant will occupy the same position as the resultant current vector, that is

$$\tan \delta = \frac{I_{\max} \sin \theta}{I_{\max} \cos \theta} = \tan \theta \quad (156)$$

The angle δ is then equal to the angle θ ; that is, if a search coil is rotated until the voltage induced in it is maximum, it will be in a position with respect to the plane of the goniometer coils corresponding to that of the plane of propagation of the radio waves with respect to the plane of the Adcock antennas. Of course, zero voltage is induced with the plane of the search coil at right angles to this maximum position; hence, the bearing can be located by rotating the search coil until a null is received and noting the position of the coil at this time.

Polarization Errors in Adcock Direction Finders.—In spite of the fact that the Adcock elements are supposedly insensitive to horizontal polarization, reception of this undesirable component of the radio wave cannot be completely eliminated for several reasons. In attempting to develop a figure of merit for direction finders (with respect to their action under conditions of abnormally polarized waves), Barfield(12) developed a "standard wave" having angles of polarization and incidence of 45 deg. each. The antenna response under the influence of this wave was then calculated. This calculation yielded the tangent of an angle which is the ratio between the magnitude of the wanted and unwanted response. The angle corresponding to this tangent is the figure of merit. For the loop antenna (single loop) this angle is 35 deg.

If the error produced by a wave is an angle ϵ , and if W is the wanted and U the unwanted response, then

$$\tan \epsilon = \frac{U}{W} \quad (157)$$

The unwanted response is given for only those cases where the spacing between Adcock elements is small compared with the wave length as

$$U = E_H S \quad (158)$$

In this expression, E_H has previously been defined and S is the

spacing between the elements of the Adcock. The wanted response is

$$W = h \sin \frac{(2\pi S \sin \gamma)}{\lambda} E_V \tag{159}$$

In this equation, h is the height of each Adcock element, γ is the incident angle, and λ is the wave length. If the spacing is small compared with the wave length and Eqs. (158) and (159) are substituted in Eq. (157), the following results:

$$\tan \epsilon = \frac{E_H \lambda}{2E_V \pi h} \cos \gamma \tag{160}$$

For the standard wave previously described Eq. (160) reduces to

$$\tan \epsilon = 0.225 \frac{E_H \lambda}{E_V h} \tag{161}$$

The value of E_H/E_V in this expression can be derived from electromagnetic theory, but it is a function of the reflection coefficient of the ground and, hence, a function of the dielectric constant and conductivity of the ground. Barfield calculated this standard wave error and found it to vary from 1 to 12 deg., depending on the particular forms of the Adcock involved.

Watson Watt(13) made some checks of Barfield's calculations and arrived at some interesting results. In Watt's experiments a large number of bearings (more than 2,000) were taken with Adcock and loop direction finders on stations of known locations. Since the loop standard wave error was accurately known, the results obtained with the loop and Adcock systems were compared and the standard wave errors of the Adcocks calculated. The results are shown in the following table:

Adcock system	Calculated error, degrees	Measured error, degrees
Balanced-coupled.....	1	4
Unbalanced-coupled....	3	4
Screened U.....	6	7

From this table it can be seen that the "residual" error due to misadjustment was larger than had been predicted by theory.

If the theoretical calculation showed a large error, the actual measurement was in good agreement, but when the calculation showed a small error, the measurement showed larger figures.

It must not be inferred that the standard wave error is the actual error that would be encountered when using Adcock antennas. The standard error is merely the figure of merit of the system, and the actual error can be greater or smaller, depending on the exact characteristics of the radio wave that is being received. It can be concluded, however, both from the theoretical discussions and the Watt measurements, that the Adcock systems do not completely eliminate horizontal component bearing errors.

The Spaced-loop Direction Finder.

FIG. 153.—Mechanical construction and connection of the spaced loop antenna system. The loops may be covered with a metallic shield if this shield is not continuous.

A means for eliminating the effects of the abnormally polarized waves on the accuracy of direction finding, which differs both in principle and construction from the Adcock system previously described, is the spaced-loop system

devised independently by R. A. Weagant in America and C. S. Franklin in England, and later investigated and developed for direction finding by T. L. Eckersley(9). In this system two loop antennas are so connected that the output

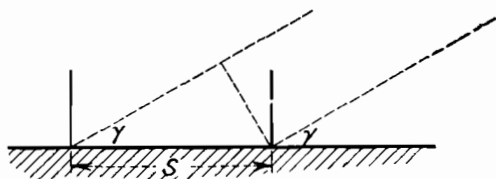

FIG. 154.—A radio wave arriving from the ionosphere and impinging on a spaced-loop system. It makes an incident angle γ with the ground.

voltages cancel; then this combined output is connected to a radio receiver. This system is illustrated in Fig. 153. In Figs. 154 and 155 the theory of the system is illustrated. In Fig. 154 is shown a radio wave with its plane of propagation

making an angle γ to the ground. This wave induces voltage in the two loop antennas. It is assumed that the distance to the transmitter is great as compared with the spacing between the antennas, so that the angles between each antenna and the direction of propagation are equal. Because of the spacing between the two antennas, a phase difference will exist which will be

$$\text{Phase difference} = \frac{2\pi}{\lambda} S \cos \gamma \quad (162)$$

In Fig. 155 the spaced-antenna system is shown subjected to radio waves arriving at an angle to the plane at right angles to

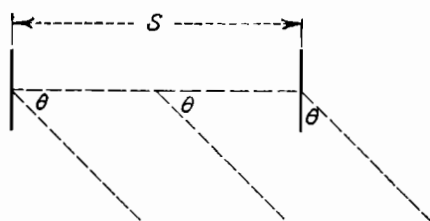

FIG. 155.—A radio wave impinging on a spaced-loop system at an angle θ with respect to the vertical plane perpendicular to the planes containing the loops. The angle θ is an azimuth angle and is contained in the horizontal plane.

the plane of the loops. The phase difference between the voltages induced in the two loops will be

$$\text{Phase difference} = \frac{2\pi}{\lambda} S \cos \theta \quad (163)$$

For a wave arriving at an angle to the ground and simultaneously at an angle to the plane at right angles to the plane of the loop antennas, the total phase difference between the voltages induced in the two antennas will be

$$\text{Phase difference} = \frac{2\pi}{\lambda} S \cos \gamma \cos \theta \quad (164)$$

For a constant known value of γ , a measurement of the angle θ indicates the direction of the transmitting station.

Effect of Abnormal Polarization on the Spaced Loop.—The resultant voltage measured at the terminals of the antenna system shown in Fig. 153 is the vector difference of the two

voltages induced. The voltage induced in each loop is expressed by Eq. (150) because each individual loop of this spaced-loop system is of the conventional type. If now the loops are rotated so that θ equals 90 deg., then the cosine is zero and the voltages induced will be in phase *regardless of the characteristics of the inducing source*; however, the connections were made in opposition so that these voltages cancel and a null is obtained. With a normally polarized wave, four nulls result—two from the positions of θ that make the loop pickup zero, and two from the positions where θ makes the phase difference between the loops zero. For the abnormally polarized wave, only two well-defined nulls result because, as has previously been explained, the presence of a horizontally polarized wave eliminates the loop nulls, and the only nulls remaining are those caused by the phase difference between the induced voltages being made zero. This, then, is an important difference between the spaced-loop and the Adcock system. The Adcock attempts to render a null by being insensitive to horizontally polarized components, whereas the spaced loops do not differentiate between the vertically and horizontally polarized components, but produce a null by making zero the phase difference between whatever voltages are induced in the two loops.

As in the Adcock, voltages induced in the horizontal components associated with the loops are sources of bearing errors, even though these components are enclosed in a grounded shield. In an attempt to eliminate this error, Eckersley arranged his loops so that they are coaxial, and hence the coupling between them and the voltage induced in the horizontal components is zero. This arrangement has the further advantage of simultaneously subjecting both loops to the same wave front.

Corrections for Other Ionosphere-propagated Wave Characteristics.—The Adcock and spaced-loop systems have as their primary purpose the elimination of the effects of the abnormally polarized components of the radio wave in direction finding, but corrections for other ionosphere-propagated wave characteristics must also be made. One of these undesirable characteristics is path deviation. Naturally, it is not possible to change this path, but it has been found that this deviation varies with time, centering about the great circle path as a norm. This statement may be subject to question, but the correction methods

are based on the theory given by it. With a direction finder employing an aural detector and manual operation, the radio operator takes as many bearings as possible in a given time. He does not attempt to determine the bearing of the null but locates bearings on either side of it. After having obtained a number of bearings in this manner, the results are averaged to obtain the actual bearing. When a cathode-ray indicator is used, the operator notices the movement of the spot and attempts to determine its center of movement.

Fading causes errors when bearings are taken manually, unless they are taken at a rate so rapid that the signal intensity does not change during the process. This, of course, is not always possible, so corrections must be supplied by the averaging system. In automatic direction finders using cathode-ray indicators, fading does not have a direct effect on the accuracy.

Attempts to correct for scattering when using the aural detector have been made by training the operators to determine bearing quality. Scattered bearings (from ground reflection) are said to have a "hollow" sound, and so are discarded. The traces of the cathode-ray indicator deviate from linear to elliptical patterns and indicate poor quality in this manner.

All the foregoing corrections hinge on methods for rejection of the bearing after it has been recorded. This type of correction is in direct contrast to the methods used for eliminating polarization errors. It is unfortunate that more direct methods have not yet been devised.

The majority of the erroneous bearings recorded with good direction finders operating at medium-high frequencies are probably caused by scattering. Fortunately, however, this phenomenon does not play an important part in the reception of radio transmissions from airplanes. Normally, the ground wave of medium-high-frequency transmitters does not traverse great distances but is rapidly absorbed. With aircraft transmitters operating on these frequencies, however, the distance from the ground is great and direct wave reception is possible up to the point where the skip zone has ended and strong reflected signals from the ionosphere appear. That is, there is no zone where strong signals (either direct or reflected) are not present (absorption of the sky wave not included). The stronger direct or ionosphere-reflected wave completely blankets the weak, scat-

tered energy which has been described as giving erroneous bearings. This is not true for reception from ground aeronautical transmissions.

Unbalanced Current Effects.—The destruction of nulls due to unbalanced currents in loop direction finders has previously been discussed in Chap. IV. These same effects are present in both the Adcock and spaced-loop direction finders. The effect may be readily minimized in the spaced-loop system by using shields around the loops, but this cannot be done with the Adcock elements. With the Adcock antenna it is necessary to preserve the balance by making the impedance of the various elements symmetrical. This is not always readily possible, because equal impedances for one frequency may unbalance at other frequencies.

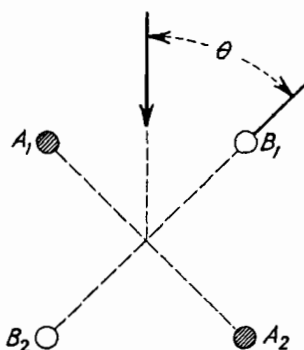

FIG. 156.—Radio wave arriving at an Adcock array from an angle θ .

Diversity Errors.—A classical paper on this subject with each proof mathematically rigorous was written by J. F. Coales(14) in 1932. This theory may be briefly illustrated by referring to Fig. 156. In this figure two pairs of Adcock antennas, A_1A_2 and B_1B_2 , are shown. Suppose now that a signal is being received from such a direction that θ equals 45 deg. During

this condition, the wave front will reach antennas A_1 and B_1 simultaneously and antennas B_2 and A_2 simultaneously. It will, however, reach antennas A_1 and B_1 before it reaches antennas A_2 and B_2 . If all four antennas are identical, the voltages induced in A_1 and B_1 will be equal and those induced in B_2 and A_2 will be equal. It does not follow, however, that the voltage induced in A_1 will be the same as that induced in A_2 . In the time interval required for the radio wave to travel from A_1 to B_2 , the reflecting layer may have changed, or the ground constants may be different along the path of propagation, thereby causing a change in the radio wave. Assume that the voltages induced in A_1 and B_1 have a magnitude of one and those induced in B_2 and A_2 a magnitude of two. The resultant voltage will be three for both pairs of antennas; hence the resultant maximum field will occur in the goniometer with the search coil at 45 deg.,

and a true bearing will result. Suppose, however, that in the second case the radio wave arrives at the fixed Adcock array from such a direction that θ equals zero. It will reach the antenna B_1 first, the antennas A_1 and A_2 simultaneously but later, and the antenna B_2 last. If for the reasons given above the voltage induced in antenna B_1 is one, that induced in A_1 and A_2 is two, and that induced in B_2 is three, the resultant voltage at the terminals of the goniometer coils will be four for each coil. The resultant field will be midway between the two coils as before, and a bearing of 45 deg. again results. This bearing is, of course, in error by 45 deg.

The foregoing discussion is not rigorous but is given to illustrate the principles involved. It is known that there are many factors which vary the magnitude of an ionosphere-propagated radio wave with time. Coales discusses at length the case where both a direct and an abnormally polarized sky wave are present. Referring to Fig. 157, a wave strikes point P' on the ground, which in this case is assumed to be a perfect reflecting surface. It is reflected and reaches a point P directly above a point O where it combines with the direct sky wave. The combined wave has a component perpendicular to the plane of incidence given by

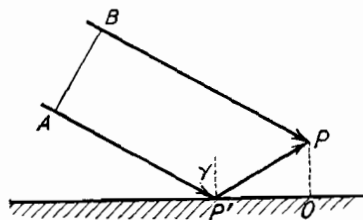

FIG. 157.—Ray of energy from an ionosphere wave reflecting from ground and combining with a direct ray from the same wave.

$$E_z = 2E_1 \sin \gamma \cos \left(\frac{2\pi h}{\lambda} \cos \gamma \right) \sin \left(\omega t + \frac{2\pi D_1}{\lambda} \right) \quad (165)$$

The ground wave is normally polarized and given by the expression

$$E'_z = E_0 \sin \left(\omega t + \frac{2\pi D_0}{\lambda} \right) \quad (166)$$

In these expressions, D_1 and D_0 are optical paths measured to point P from a common starting point. Upon striking the Adcock elements, voltages will be induced which are functions of the Adcock antenna heights h . If E_G and E_A are defined as

$$E_G = 2E_0 \int_0^h f(h) dh \quad (167)$$

$$E_A = 4E_1 \sin \gamma \int_0^\lambda f(h) \cos \left(\frac{2\pi h}{\lambda} \cos \gamma \right) dh \quad (168)$$

then the current flowing in the coil connected between the antennas A_1 and A_2 will be

$$I_A = E_G \sin \left(\frac{\pi D}{\lambda} \cos \theta \right) \cos \left(wt + \frac{2\pi D_0}{\lambda} \right) + E_A \sin \left(\frac{\pi D}{\lambda} \cos \theta \sin \gamma \right) \cos \left(wt + \frac{2\pi D_1}{\lambda} \right) \quad (169)$$

and that flowing in coils connected between antennas B_1 and B_2 will be

$$I_B = E_G \sin \left(\frac{\pi D}{\lambda} \sin \theta \right) \cos \left(wt + \frac{2\pi D_0}{\lambda} \right) + E_A \sin \left(\frac{\pi D}{\lambda} \sin \theta \sin \gamma \right) \cos \left(wt + \frac{2\pi D_1}{\lambda} \right) \quad (170)$$

In this expression, D is the spacing between Adcock elements. If the coils mentioned above had been the fixed coils of a goniometer, they would induce voltage in the rotating coil. The voltage so induced will be some linear function of the current in the fixed coils; hence,

$$EK = I_B \cos \psi - I_A \sin \psi \quad (171)$$

In this expression, the angle ψ is the angle between the axis of the rotatable coil and the axis of one of the fixed coils. It corresponds to the angle θ for the Adcock in Fig. 160. Substituting in Eq. (171) the values of I_A and I_B given by Eqs. (169) and (170), the following equation results:

$$EK = E_G \left[\cos \psi \sin \left(\frac{\pi D}{\lambda} \sin \theta \right) - \sin \psi \sin \left(\frac{\pi D}{\lambda} \cos \theta \right) \right] \cos \left(wt + \frac{2\pi D_0}{\lambda} \right) + E_A \left[\cos \psi \sin \left(\frac{\pi D}{\lambda} \sin \theta \sin \gamma \right) - \sin \psi \sin \left(\frac{\pi D}{\lambda} \cos \theta \sin \gamma \right) \right] \cos \left(wt + \frac{2\pi D_1}{\lambda} \right) \quad (172)$$

In order to secure a null the rotatable coil is adjusted, thereby changing the angle ψ . An examination of Eq. (172) shows

that it is hardly possible to find a value for ψ that will give a clear null.

Coales calculated the possible magnitude of error due to diversity and arrived at an angle of as much as 90 deg. Although his discussion centered around the presence of both a sky wave and a ground wave, two or more sky waves (as discussed under Fading) could cause similar effects. The discussion of diversity error was based on fixed Adcock antennas, but the same effect could be true for any fixed direction-finding array. This error may be minimized by using small spacing between antenna elements, but the true solution consists in rotating the array so that the wave front always strikes both antennas of a significant pair simultaneously.

Minimum Signal-strength Error.—Errors due to insufficient signal have been mentioned previously and are discussed here only to contrast the spaced-loop and Adcock systems. On the assumption that a bearing is to be located by determining the direction of the null, it is evident that a null cannot be obtained unless a signal is present. If no noise (caused by atmospherics or apparatus or both) is present, only a slight amount of signal is necessary in order to obtain a satisfactory bearing. If, however, the value of the noise is high, an appreciable signal is required in order to obtain a sharp null.

Referring to Eq. (154), the voltage output of an Adcock system was given as

$$E_A = LK' \cos \theta \cos \phi \cos^2 \gamma \quad (154)$$

The difference between the voltages induced in the loops of a spaced-loop system is, under certain limited conditions, proportional to the phase difference, or

$$E_{SL} = LK'' \cos \gamma \cos \theta \quad (173)$$

The voltage pickup by the loops (individually) is also a function of the angles of incidence, polarization, and direction as shown by Eq. (150); hence the total output voltage of the spaced loops is

$$E_{SL} = EK''' \cos \gamma \cos \theta (\cos \phi \cos \gamma \cos \theta + \sin \phi \sin \gamma \sin \theta + \cos \phi \sin^2 \gamma \cos \theta) \quad (174)$$

The relative voltage output of the spaced-loop and Adcock system is obtained by dividing Eq. (174) by Eq. (154), assuming that the field strength is the same for both cases.

$$\frac{E_{SL}}{E_A} = \frac{K'''}{K'} (\cos \theta \tan \phi \tan \gamma \sin \theta + \tan \gamma \sin \gamma \cos \theta) \quad (175)$$

All the angles mentioned in the preceding discussion refer to Fig. 147.

From the foregoing expression it can be seen that as the angle of polarization ϕ approaches a value of 90 deg., the output of the loop system becomes much greater than that of the Adcock system. That is, for abnormally polarized waves the output of the spaced-loop system will be greater than that of the Adcock system for the same effective height of antennas. This conclusion agrees with what has previously been said about the Adcock. This system is not sensitive to horizontally polarized waves; so if a wave is purely horizontally polarized it would make no impression on the Adcock antenna, but it could still be received with the spaced loops.

Equation (175) reveals another interesting fact regarding the relative output signals of the Adcock and spaced-loop systems. From the second term in Eq. (175), it can be seen that as the incident angle γ approaches 90 deg. the output of the spaced-loop system becomes infinitely greater than that of the Adcock system. Referring to the physical aspect, with reception within or just on the border of the skip zone, it is very difficult to obtain sufficient signal strength to determine a null with the Adcock, but the spaced loops may still produce a usable signal.

Terrain Errors.—The terrain surrounding a medium-high-frequency direction finder is an important factor in determining the accuracy of bearings obtained with any unit regardless of its principle of design.

Errors caused by the terrain may be classified under the three general headings of surface, obstruction, and substrata.

Surface errors have already been discussed in Chap. III. Briefly, they appear to be caused by skewing of the wave front as the energy travels from terrain of one conductivity and dielectric constant to that having a different conductivity and dielectric constant. Surface errors have been recognized with

long-wave direction finders located some distance in from a sea-shore. The abrupt change in conductivity between ocean water and land presents a situation analogous to the bending of the rays of light as they pass from air through water. This effect is also found in mountainous terrain, where apparently there are abrupt changes in conductivity from the watered valleys to the rocky formations of the mountains. Since the medium-high-frequency waves are rapidly attenuated by the terrain, the importance of this surface-of-the-ground phenomenon in causing bearing errors is subject to question. The ground plays a part in determining the accuracy of bearings from the direct wave (ground wave) of a transmitter. However, in the introduction it was stated that this chapter would be confined to the discussion of waves propagated via the layer, so this effect will not be considered. In transmission at great distances it has been proved that radio waves reflected to earth from the ionosphere are often reflected back by the earth and then again rereflected by the ionosphere. It is possible to think of the terrain at this time skewing the wave front, and in this case the results would be indistinguishable from those produced by *path deviation* (previously discussed). Certain radio waves strike the earth in front of the direction finder and are reflected to the antenna array as is shown in Fig. 157. At the antenna array they meet the stronger rays which have arrived directly from the ionosphere, and it is important, therefore, that the terrain surrounding the direction finder does not have great discontinuities in its electrical characteristics. If the distance from which bearings are to be taken and the height of the reflecting layers are known, it is easily possible to calculate the distance adjacent to the direction finder, where uniform ground characteristics should prevail, in order that errors may be avoided. Substrata layers deal with the same propagating phenomena that have been mentioned for surface errors. That is, errors from substrata affect only those rays which are reflected from the ground. These errors occur when (because of the very poor electrical-conducting properties) the wave enters the ground and strikes a better conducting layer. This layer may lie at nonuniform depths and possibly may have an outcropping at some portion of the terrain about the direction finder and thus serve to produce a distorted wave front upon reflection. As far as the medium-high-frequency waves are con-

cerned, the effects of the substrata and surface are hardly distinguishable. One difficulty is corrected by surrounding the direction finder with uniform terrain, whereas the solution of the other requires uniform ground characteristics in the vertical plane below the surface of the earth. Where the ground is suspected of being a poor conductor, the effects of these phenomena may be guarded against by the use of an extensive ground screen.

Obstructions are probably the most significant factor in causing terrain errors of medium-high-frequency bearing. Conducting members (such as telephone and power wires, as well as semiconductors such as trees) serve to absorb and reradiate energy and by so doing affect the normal field of the radio waves. This phenomenon is analogous to the effects of a bridge pier on the normal flow of a stream. Like the stream, however, the field pattern of the waves returns to normal at some distance from the obstruction. An example of this phenomenon has been observed in one case where a direction finder located under some wires produced a bearing error of 70 deg., but at less than one wave length from the wires, the error was reduced to some 3 deg. A rule(16) established by Eckersley(9) is that the obstruction should not subtend an angle of more than 3 deg. at the direction-finder site. By following this rule it has been possible to obtain some good bearings when locating a direction finder on a plateau in mountainous terrain.

Instrument Errors.—Instrument errors are those inherent in the design or manufacture of the device. These errors can be caused by any of the following conditions or combinations of them:

1. Indicator nonlinearity
2. Amplitude unbalance between two members of an antenna pair
3. Phase unbalance between two members of an antenna pair
4. Phase or amplitude differences of one pair of antennas (in an Adcock) relative to the other pair

All these errors can be eliminated by moving an oscillator around the periphery of a circle having the direction finder at its center and determining the error curve. The errors read from this curve are then applied to correct bearings.

In order to avoid errors during this calibration because of the proximity of the oscillator to the direction-finder antenna, it

is necessary that it be located at a distance from the direction finder. Ideally, this distance should be very great. Actually, however, if the oscillator is moved too far from the direction finder, the radio waves generated by it will be affected by obstructions at most of the usual locations. There is, then, a compromise distance at which the oscillator may be located. Curves showing this distance as a function of spacing between antenna elements for errors of $\frac{1}{2}$ and $\frac{1}{4}$ deg. have been calculated by Ross(17) and are shown in Figs. 158 and 159. These curves may be summarized by stating that for spacing between direction-

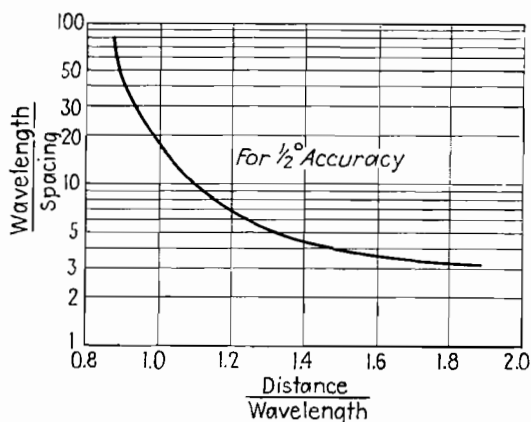

FIG. 158.—Relation between antenna element spacing and proximity of oscillator to antenna to result in calibration errors of one-half degree or less. (Courtesy of Institution of Electrical Engineers.)

finder antenna elements not exceeding one-quarter wave length the oscillator should be placed at a distance of 1.4 wave lengths for an error of $\frac{1}{2}$ deg. and 2.4 wave lengths for an error of $\frac{1}{4}$ deg.

Medium-high-frequency Direction Finders Used in the United States.—There are three types of medium-high-frequency direction finders used for commercial aviation in the United States. One system was developed by the Pan American Supply Corporation, one was manufactured by the Western Electric Company, and one was developed by United Air Lines. A brief description of these systems follows.

Pan-American System.—This system consists of two sets of Adcock antennas. The spacing between the antennas of one set is approximately 200 ft., and between the other set it is

approximately 80 ft. The outer set is intended for use in the band 200 to 2,000 kc. and the inner set operates from 2,000 to 6,000 kc. These antennas take the form of vertical dipoles and are made of 1 in. diameter brass rod with an over-all length of about 18 ft. Each rod is supported by wooden crossbars mounted to two wooden poles (per antenna). The height of these poles is about 25 ft. At the center of each vertical dipole is located a cast-aluminum box containing an adjustment. The controls of this adjustment can be manipulated from the ground by a long wooden pole. Unshielded twisted pairs run from each

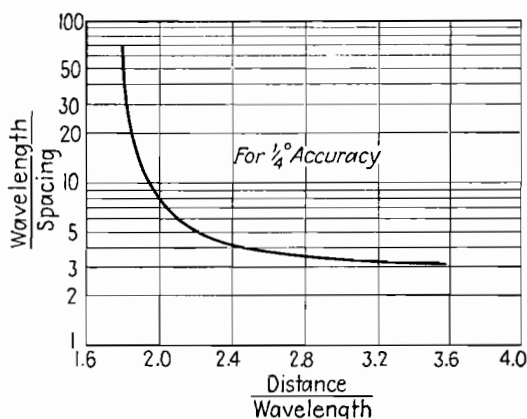

FIG. 159.—Relation between antenna element spacing and proximity of oscillator to antenna to result in calibration errors of one-quarter degree or less. (Courtesy of Institution of Electrical Engineers.)

of these boxes to the equipment house which is located in the center of the diagonals between the antennas. Here they connect to a manually operated goniometer which, in turn, is connected to a suitable receiver. The bearing is indicated by an aural null. In taking bearings the operator makes a number of observations over a period of 2 to 3 min. In making these observations the bearing of the null is not recorded, but the positions are recorded on each side of it where convenient sound levels exist. The average of these readings is assumed to be the true bearing.

Western Electric System.—This system utilizes an H type Adcock antenna together with a vertical or sense antenna. A number of poles about 25 ft. high support both the antennas and a house in which the receiving apparatus is contained. These antennas are about 20 ft. high and are only 12 ft. apart.

The indicator is located some distance from the direction finder and receives its actuating energy via a telephone line. The indication is a direct-reading pattern on a cathode-ray oscilloscope. Its operation is based on a principle somewhat as follows: Audio frequencies are generated at the observation station and are sent down the telephone line to modulate four cardioid patterns produced by the energy from the vertical antenna and the Adcocks taken in various relations. The modulated energy is detected and the resulting audio frequencies are returned to their originating source. Here they actuate the four deflecting plates of the cathode-ray tube, and hence the cathode spot is made to assume a position proportional to the relative phase and amplitudes of the four audio signals. Since these are, in turn, a function of the relative amplitudes and phase of the four cardioid patterns, the position must be the bearing.

A remote transmitter operating on the frequencies to be received is located at a known point. Prior to taking a bearing, this transmitter is operated and an initial adjustment is made by the observer. The cathode spot gives a steady deflection on the scale of the tube under certain conditions, but often it varies in direction and amplitude. Under these latter conditions it is necessary for the operator to interpret the results.

United Air Lines System.—This system consists of two units. One of these is the direction finder proper located in an area clear of obstructions, and the other is the indicator unit located at the airport. The direction finder makes use of a pair of large spaced loops mounted on a wooden house. This house serves both as an antenna mounting and as a cabinet for the receiving equipment.

Problems

1. At what azimuthal angle will a minimum signal taken with a loop direction finder occur if the angles of polarization and incidence are both 45 deg.?

2. The difference between the response of an Adcock antenna to a wave when horizontally and when vertically polarized was measured to be 30 db. What will be the polarization error of this antenna to this wave?

3. An ionic cloud is located 30 km. above the earth and has irregularities in its surface with depths of one wave length. Beyond what distance could scattering be expected to be absent? Disregard characteristics of the cloud other than the depth of its irregularities.

4. A direction-finder antenna is located 20 ft. above the ground and is to take bearings on stations located 1,000 miles away. Reception of these

waves is expected from a layer at a height of 250 km. How far from the direction finder should a ground screen extend in order to assure freedom from surface and subterranean terrain errors?

Bibliography

1. TERMAN, F. E.: "Radio Engineering," p. 555, McGraw-Hill Book Company, Inc., New York, 1932.
2. NAMBA, SHOGO, EIJI ISO, and SHIGETOSHI UENO: Polarization of High Frequency Waves, *Proc. I.R.E.*, Vol. 19, No. 11, p. 2000, November, 1931.
3. HEISING, R. A., J. C. SCHELLENG, and G. C. SOUTHWORTH: Some Measurements of Short Wave Transmissions, *Proc. I.R.E.*, Vol. 14, pp. 613-697, October, 1926.
4. BREIT, S.: A Suggestion of a Connection between Radio Fading and Small Fluctuation in the Earth's Magnetic Field, *Proc. I.R.E.*, August, 1927, p. 709.
5. FRIS, H. T.: Scillographic Observations on the Direction of Propagation and Fading of Short Waves, *Proc. I.R.E.*, May, 1928, p. 658.
6. BARFIELD, R. H., and W. ROSS: The Measurement of the Lateral Deviations of Radio Waves by Means of a Spaced Loop Direction Finder, *Jour. I.E.E.*, Vol. 83, p. 99, 1938.
7. FELDMAN, C. B.: Deviation of Short Radio Waves from the London-New York Great Circle Path, *Proc. I.R.E.*, October, 1939, pp. 635-645.
8. TAYLOR, A. HOYT, and L. C. YOUNG: Studies of Echo Signals, *Proc. I.R.E.*, September, 1929, p. 1491.
9. ECKERSLEY, T. L.: Scattering, Polarization Errors and the Accuracy of Short Wave Direction Finding, *Marconi Rev.*, Vol. 53, pp. 1-8, Vol. 54, pp. 20-30, 1935.
10. EDWARDS, C. F., and KARL G. JANSKY: Measurements of the Delay and Direction of Arrival of Echoes from Nearby Short-wave Transmitters, *Proc. I.R.E.*, June, 1941, pp. 322-329.
11. KEEN, R.: "Wireless Direction Finding," 3d ed., p. 252, Iliffe & Sons, London, 1938.
12. BARFIELD, R. H.: Some Principles Underlying the Design of Spaced-aerial Direction Finders, *Jour. I.E.E.*, Vol. 76, p. 423, 1935.
13. WATT, WATSON: Polarization Errors in Direction Finders, *Wireless Engineer*, Vol. 13, p. 3, 1936.
14. COALES, J. F.: A Note on the Theory of Night Errors in Adcock Direction Finding Systems, *Jour. I.E.E.*, Vol. 71, p. 497, 1932.
15. ADCOCK, F.: Improvement in Means of Determining the Direction of a Distant Source of Electromagnetic Radiation, British Patent 130,490, 1919.
16. KEEN, R.: "Wireless Direction Finding," 3d ed., p. 288, Iliffe & Sons, London, 1938.
17. ROSS, W.: The Calibration of Four Aerial Adcock Direction Finders, *Proc. I.E.E. Wireless Sec.*, Vol. 14, p. 299, 1939.

CHAPTER IX

MEDIUM-HIGH-FREQUENCY COMMUNICATION

In 1929, the Post Office Department encouraged air-mail carriers (which at that time were practically the only commercial transport operators in existence in this country) to install two-way radio communication by increasing mileage pay for airplanes equipped with both radio receivers and transmitters. Why the Post Office Department made this move is not known, but it probably had to do with the necessity for airplane-arrival information. Flying in those early days was greatly dependent on the weather, and a headwind meant large departures from schedule. If an overcast was encountered, the airplane landed at the nearest emergency field and waited. Sometimes this emergency field was a regular government-maintained airport, but often it was any open area. When the transport operators installed this communication equipment, they asked the pilots to make periodic reports, and for the first time the progress of the flight was known to the ground personnel. This information was very important, because when the pilot decided to make an unscheduled landing, a crew could be sent out to take care of the mail and the airplane. When a few passengers began to appear on the lines, radio communication was the means that saved them from undue hardships attending an unscheduled landing in mountainous terrain.

As the airlines grew and transport flying became a more precise business, accurate knowledge of the airplane's progress was absolutely essential. The introduction of meteorologists and qualified flight personnel on the ground made a communications system between pilots and these ground people imperative. The ability of two pilots, one ahead of the other, to discuss while en route the weather conditions encountered is another valuable facility provided by two-way communications. The present crowded airports and airways have made imperative accurate knowledge of the position of each airplane, and a

maneuver by any airplane cannot be made until the plans of the pilot are first transmitted to and approved by control groups on the ground.

Naturally, the development of this communications system required a period of time. Besides determining the mode of communication to be used and the frequency that this mode was to employ, reliable transmitters and receivers capable of giving satisfactory service under these new conditions had to be designed. The term "new" may be subject to question, for it is a fact that two-way radio-telephone communication was used in the latter days of the First World War; however, the development was stopped with the cessation of hostilities, and the conditions peculiar to long-range airplane-to-ground communications required much added development.

Some of the problems that were solved were discussed in the first chapter. The outcome of all the investigations was, for the continental airlines of the United States, radio telephony using two frequencies. A frequency of about 6 megacycles is employed during the daylight hours and exchanged for a frequency of about 3 megacycles during the night hours. The transmitter power used was originally 50 watts. This means that the transmitter was capable of delivering 50 watts of power into a good antenna (but not necessarily an airplane antenna). With the arrival of the newer art in vacuum tubes, the power of these transmitters has increased so that the common power output is now about 100 watts. One transmitter with a power output of 250 watts has been designed. Frequency control using quartz piezoelectric plates was incorporated in the first of the transmitters and later was extended to control the tuning of fixed-frequency receivers. The first antennas used were trailing wires which were electrically efficient but operationally impractical. These were short-lived and were soon replaced by fixed structures. The earlier requirements for small airplanes barred the radio operator, and the advantages of equipment that the pilot can use without the necessity of an intermediary have been reasserted over and over since those early days.

The transport operator, contrary to the European practice of government-operated ground stations, installed his own ground facilities. The installation of the radio station on the ground

also involved much development. The questions of how much power and what spacing between stations had to be answered. As commonplace as it is today, in 1928 to 1930 the medium-high-frequency high-powered station was still a somewhat mysterious quantity. The early ground station consisted of an aircraft transmitter equipped with a power amplifier. The same receiver used in the aircraft was also used for reception on the ground.

The history and character of this commonly used communication system having been sketched, its propagation characteristics will now be discussed.

Calculating the Strength of Airplane Signals.—Means for calculating the field strengths of these signals have recently become available but were unknown when the first installations were made. One of the methods(1) which has given results that are in good agreement with measurements is that developed by Charles R. Burrows and Marion C. Gray. The portion of their method that applies to the transmission of radio waves between an airplane and ground will be described without attempting to show its mathematical derivation. The following equation for field strength E is a modified form of the Burrows and Gray original:

$$E = E_0 \left(\frac{A F_s G_1 C_2}{d} \right) \quad (176)$$

In this expression, there are two factors for the field strength at any given point. The first is the term E_0 expressing the value of the *radiation* field near an antenna. This term is a function of the current flowing in the antenna and its effectiveness as a radiator. It has no bearing on the characteristics of the ground, since the distance from the antenna to the point where E_0 was measured is very short. This field strength must, however, be that at a distance that is large compared with the dimensions of the antenna; furthermore, it must be at a distance sufficiently great (more than two wave lengths) so that it cannot be confused with the induction field of the antenna. At medium-high and lower frequencies the convenient distance of 1 mile can be used for this measurement. The value of E_0 can be calculated if the power into the antenna and its efficiency are known. One watt of power into a 100 per cent efficient quarter-wave antenna will produce a field strength of 6,140 μv per meter at a distance

of 1 mile(2). This figure multiplied by the square root of the power will be the field strength produced by the same antenna for any amount of power. The subject of aircraft-antenna efficiency and aircraft-transmitter power will be discussed later. Both E and E_0 should be expressed in the same units.

The second factor in the foregoing expression is the attenuation factor. This factor consists of five terms. The term $1/d$ gives the "natural" attenuation of the wave due to its propagation in free space. The letter d is the distance from the antenna to the point in question. This distance is expressed in units corresponding to the distance from the antenna at which E_0 was measured. That is, if E_0 was measured 1 mile from the antenna, then d is in 1-mile units; if at a distance of 5 miles, then d is in 5-mile units, etc.

The term A_1 is the plane earth attenuation factor and is read directly from the curve of Fig. 163A. This figure shows eight curves. Six of these curves apply to vertical, one to horizontal, and one to both types of transmission. The usual transmission from airplanes makes use of vertical polarization. The proper curve is selected by determining the value of the auxiliary quantity Q from

$$Q = \frac{\epsilon}{60\sigma\lambda} \quad (177)$$

In this expression, ϵ = dielectric constant of the terrain as given in Table III

σ = conductivity of the terrain, mhos per meter

λ = wave length, meters

After having determined Q , it is necessary to determine the distance parameter ζ . This parameter for vertically polarized waves can be calculated from the formula

$$\zeta = \frac{3,218d}{\lambda} \left[\frac{\pi}{\sqrt{\epsilon^2 + (60\sigma\lambda)^2}} \sqrt{\frac{(\epsilon - 1)^2 + (60\sigma\lambda)^2}{\epsilon^2 + (60\sigma\lambda)^2}} \right] \quad (178)$$

In this expression d is the distance from the transmitter to point of reception in miles. All other symbols have been defined previously.

The term F_s in Eq. (176) is the shadow factor due to the earth. Burrows and Gray give this factor in Figs. 2 and 3 of the paper

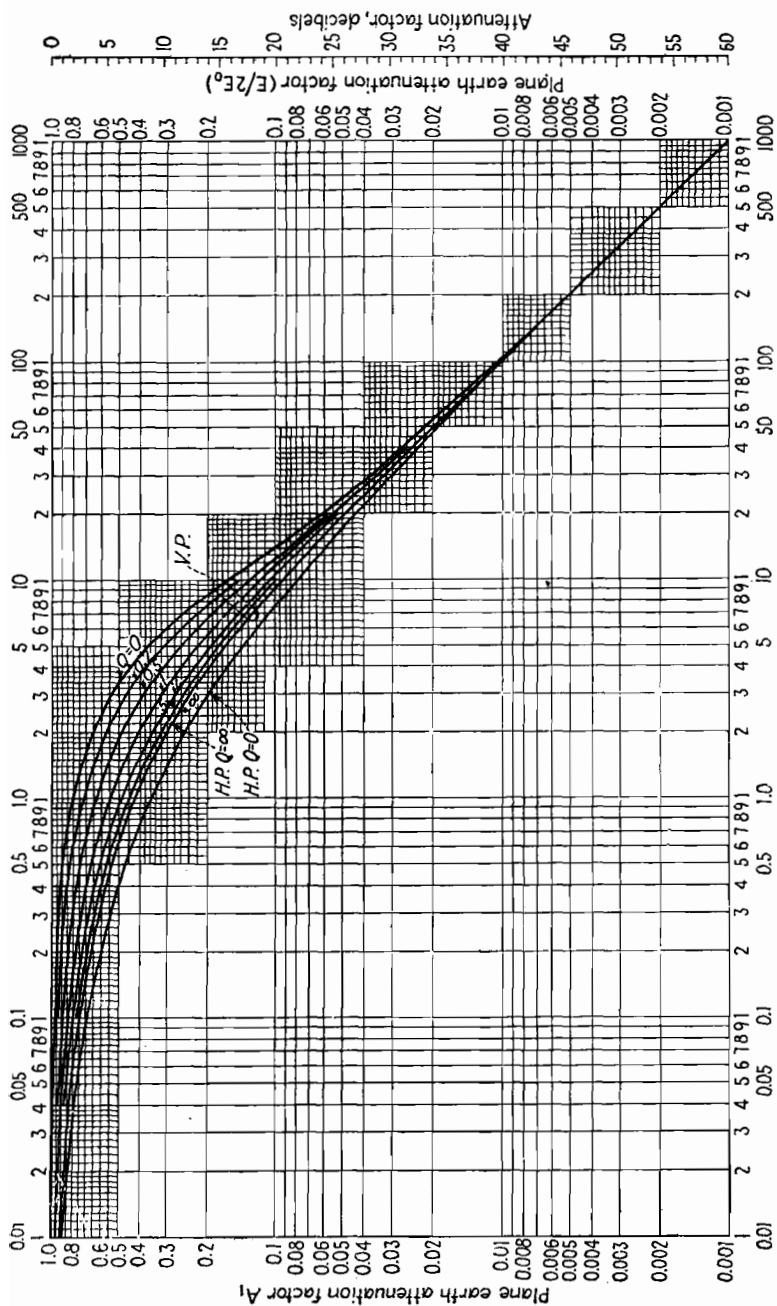

Fig. 160A.—Plane earth attenuation factor as a function of the distance parameter ξ . (Courtesy of Institute of Radio Engineers.)

previously referred to(1). The curves of Fig. 3 apply to terrain of any character, but in order to use them it is necessary to determine the auxiliary quantities ζ_a and $f(\delta)$. The curves of Fig. 2 apply only to the limiting conditions where the ground is either a pure dielectric or a perfect conductor; however, these curves can be used merely by determining the quantity ζ_a (to be

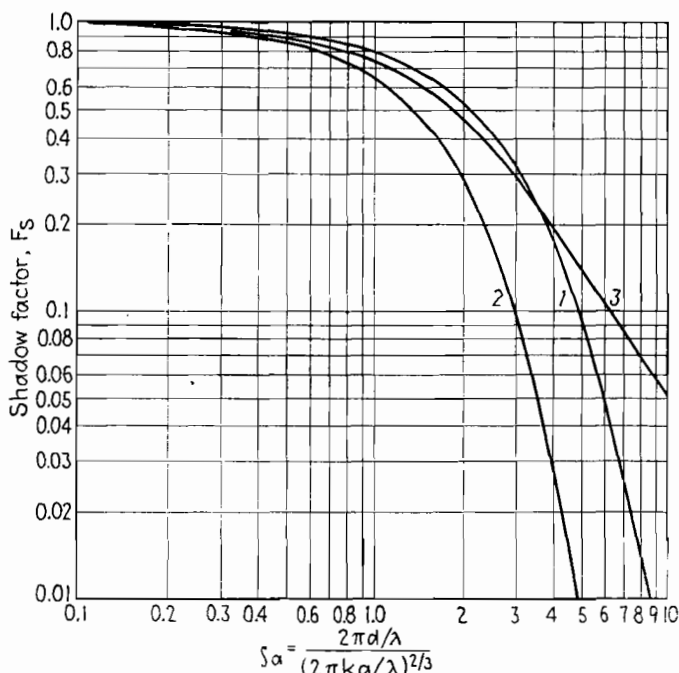

FIG. 160B.—The shadow factor as a function of ζ_a . Curve 1 applies for vertical polarization over perfectly conducting earth. Curve 2 applies for vertical polarization over perfectly absorbing earth. Curve 3 is the approximate shadow factor derived from ultra-high-frequency propagation over land. (Courtesy of Institute of Radio Engineers.)

later defined). Figure 2 of the Burrows and Gray paper is reproduced as Fig. 160B. This curve can be used without appreciable error if ζ_a is not larger than unity. For values of ζ_a larger than unity, Fig. 160B can still be used for estimating purposes.

The distance parameter can be determined from

$$\zeta_a = \frac{0.072d}{\sqrt[3]{\lambda}}$$

In this expression, d and λ have been previously defined.

The last two factors in Eq. (176) represent the gains of the transmitting and receiving sites. These factors are obtained by calculating the factor χ from

$$\chi = \frac{0.6096\pi h}{\lambda \sqrt{\epsilon^2 + (60\sigma\lambda)^2}} \sqrt[4]{\frac{(\epsilon - 1)^2 + (60\sigma\lambda)^2}{\epsilon^2 + (60\sigma\lambda)^2}} \quad (179)$$

In this expression h is the height of the antenna from the earth expressed in feet. After χ has been calculated and found to have

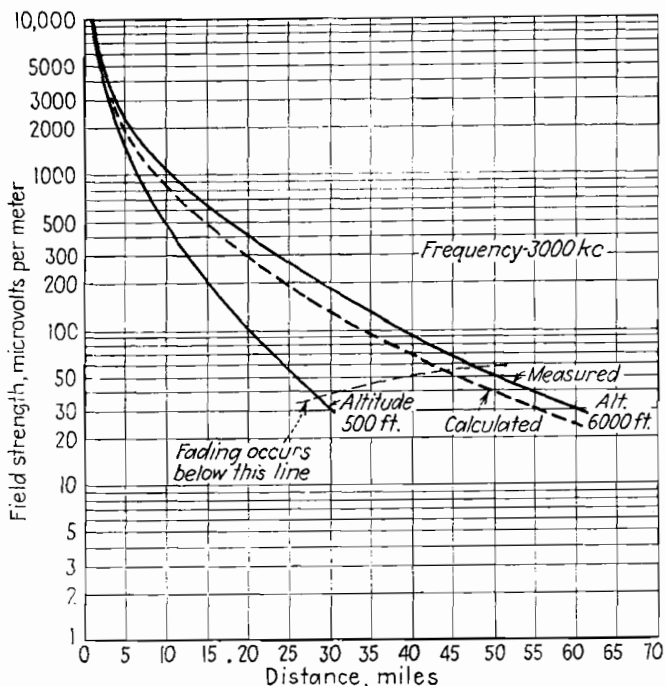

FIG. 161.—Field strength of airplane signals at a frequency of 3000 kc. [Measured data courtesy of American Institute of Electrical Engineers. See Ref. (3).]

a value less than five, it may be applied to Fig. 7 of the Burrows and Gray paper to obtain the gain factor. If it has a value greater than five, then χ equals G . For the usual aircraft-to-ground communication the ground-antenna site will have a value of G approximately equal to unity, and the aircraft-antenna site will have a large gain value; so in Eq. (176) unity may be substituted for the value of G_1 , and the value of χ in Eq. (179) may be substituted for G_2 .

Several computations have been made, and the resulting data are shown by dotted curves on Figs. 161 and 162. In these calculations the field strength at 1 mile was taken from measured values, but with this knowledge it can be seen that the correlation between measured and calculated values is well within the limits of experimental error.

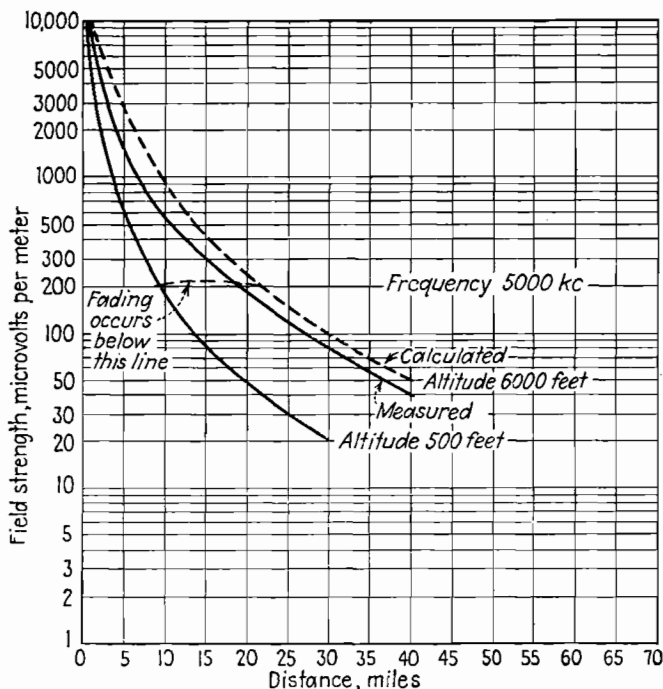

FIG. 162.—Field strength of airplane signals at a frequency of 3,000 kc. [Measured data courtesy of American Institute of Electrical Engineers. See Ref. (3).]

Characteristics of Airplane Signals.—In Figs. 161 and 162 are shown the strengths of signals from airplanes(3). The data shown in the solid lines were measured, and those shown in dotted lines were computed by the method just described. One of the first principles illustrated by these figures is the variations in signal strength with airplane altitude. In Fig. 161 is shown an increase in signal strength from 30 to 180 μ v per meter by an increase in altitude from 500 to 6,000 ft.

TABLE III

Terrain	Dielectric constant	Conductivity, mhos per meter
Sea water.....	80	4
Fresh water.....	80	5×10^{-3}
Moist soil.....	30	0.02
Fertile land.....	15	5×10^{-3}
Rocky ground.....	7	1×10^{-3}
Dry soil.....	4	1×10^{-2}
Very dry soil.....	4	1×10^{-3}

Referring to the relative values of the field strengths in Figs. 161 and 162, it will be seen that the higher frequency transmission attenuates more rapidly than that of the lower frequency signals. This characteristic is, of course, also true of transmissions on the ground. The question naturally arises as to the signal strength that is required for satisfactory reception. With present-day technique it is possible to amplify signals tremendously. The only limitation is the noise produced in the amplifiers or present in the atmosphere and incapable of being filtered out in the selective circuits of the receiver. The inherent noise in a receiver still permits reception at inputs as low as $1 \mu\text{v}$; however, atmospheric noises are often much greater than $1 \mu\text{v}$. One measurement of atmospheric noise shows $3.5 \mu\text{v}$ per meter at noon to $12 \mu\text{v}$ per meter at midnight for a 6-megacycle signal, and $1.4 \mu\text{v}$ per meter at noon to $14.5 \mu\text{v}$ per meter at midnight on 3 megacycles. Referring to Figs. 161 and 162, it can be estimated that a 1 to 1 (or better) signal-to-noise ratio can be maintained for distances up to 75 miles on 3 megacycles and up to 60 miles at 6 megacycles with a minimum altitude of 6,000 ft. This is approximately the minimum flight altitude used by commercial airplanes.

For economical reasons the necessity for locating radio stations at points solely for communication purposes is undesirable. That is, although communication stations are desired at all the terminals that an air transport uses in the course of its regular flight, the expense of operating radio stations at intermediate points solely because they are required in order to furnish communications is to be avoided. In the past, however, certain

stations have been established primarily because of the necessity for communications. As an average, air-transport terminal points are spaced about 200 miles apart. Communications are desired from the terminal from which the craft departs to the airplane until it reaches a point midway from the place of departure to the next terminal. At this time communication is transferred from the station behind to that ahead. It can be seen that the minimum necessary range is 100 miles. In order that reports and requests from the aircraft be relayed back to the point of departure, it is necessary that the ground stations maintain communication at distances of 200 miles. In recent years there have been established long nonstop flights, and with these the service to many of the less important (from a commercial standpoint) terminals has been curtailed. When this is done, the station personnel number only those that are required to handle the infrequent trips; hence, it is necessary that the terminal station communicate with the airplane at distances up to 200 miles. With the present trend toward centralized ground control, the demand has arisen (but has not been met altogether) for communications at distances up to 1,000 miles.

Bearing these factors in mind and referring to Figs. 161 and 162, it can be seen that direct transmission can furnish only marginal service.

Characteristics of the Ionosphere.—The selection of frequencies in the medium-high range brings in a phenomenon that makes possible transmission over long distances with a transmitter having an output field strength as pictured in Figs. 161 and 162. This phenomenon is the reflection of radio waves from ionized gas layers which exist above the surface of the earth. The presence of such layers was predicted(4) in 1902 by A. E. Kennelly in this country and independently by Oliver Heaviside in England. In 1925, Appleton and Barnett reported direct evidence of such a layer, and in 1927 Appleton detected a sudden change in the virtual height of the layer and concluded that two layers were present. Subsequent to that time, workers have found the presence of a third layer, and some recent work indicates that a lower layer is also present. Although it is common practice to speak of the existence of a number of reflecting layers, actually it is not believed that separate gas layers with un-ionized spaces between them exist. Rather, it is believed

that there is a single ionized gas region in which the ionization varies with height in such a manner that more or less well-defined boundaries exist. As the radio wave propagates in all directions from the transmitting antenna, some ray may reach the receiver in the manner evaluated in the previous discussion, but some of the remaining rays reach the ionized area discussed above and referred to as the ionosphere. Where the ray reaches this area, it is bent back to earth with but slight attenuation. The effect is as if it had struck a perfect reflector located at a certain

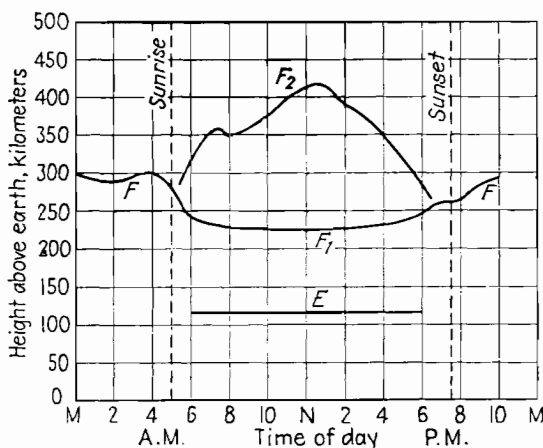

FIG. 163.—Variation in the virtual height of the ionosphere layers with time of day. (Courtesy of Institute of Radio Engineers.)

height. This concept is an easy one to picture, and all measurements of these layers have been made on this basis.

The present concept of the ionosphere assigns to it three daytime layers and two night layers. The day layers are designated by the letters E , F_1 , and F_2 . The night layers are designated as E and F . The F night layer is formed from the combination of the F_1 and F_2 daytime layers. The E layer has a height of 100 km. plus or minus 20 for day, night, changes in seasons, and latitudes. The F layer has a height of 250 km. plus or minus 50 for changes in seasons and latitudes. The F_1 layer has a height of 200 km. plus or minus 30 for seasons and latitudes. The F_2 layer has a height from 250 to 450 km., and this height varies with time, latitude, and seasons. The variation of the height of these layers with time of day is shown in Fig. 163.

Another characteristic of the gas layers is their density, which is very important in so far as communication is concerned. The measurement of this density is made daily by the Bureau of Standards. This density is ascertained by determining the frequency of the radio wave which, when striking the layer at *normal incidence*, just passes through the layer. This frequency is termed the "critical" frequency of the layer(5). With this knowledge, it is possible to determine the density in electrons

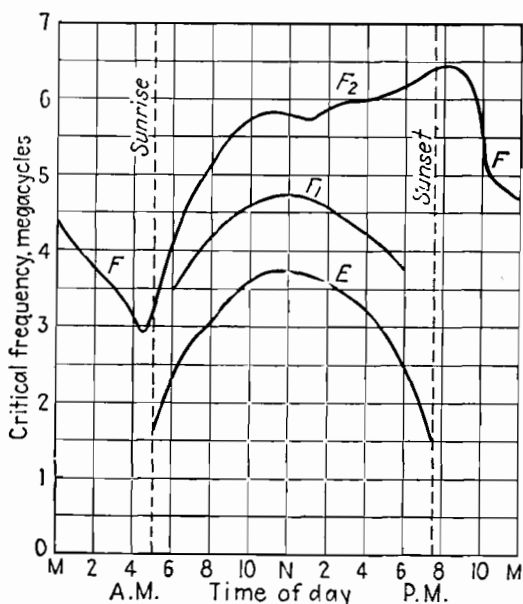

FIG. 164.—Critical frequency of the ionosphere layer with time of day. (Courtesy of Institute of Radio Engineers.)

per cubic centimeter; however, the density of the layer in terms of its ionic content is no longer published, as the critical frequency is of greater interest to the engineer.

Curves giving critical frequency for various hours are shown in Fig. 164. The data represented in Fig. 164 are the average for the month(6) of July, 1941. It can be seen from this curve that the density of the layers varies greatly with time of day. With the exception of the F_2 layer, the greater density (that density which passes the smallest wave length or the highest frequency) occurs at noon when the rays of the sun are exerting

their greatest influence. From this observation it would be expected that the density would also vary with the seasons, and this is actually the case.

The density of the layers also varies with sunspot activity. In 1933, a year of low sunspot activity, the critical frequencies measured for the layers were low, whereas in 1937 they were much higher. Certain correlation has also been found between layer density and the square of the exposed sun area during eclipse. The density is apparently also affected by terrestrial magnetism.

The Ionosphere in Aircraft Communications.—In Figs. 161 and 162 are lines marked with the wording “severe fading occurs below this line.” These lines mark the areas where the first energy reflected from the ionosphere is received. This energy, for the cases shown, arrives in an area where the direct transmission is still strong. It combines with the direct energy and, depending on the relative phase of the two, either enforces or detracts from the original signal strength, thereby causing fading. For ground transmission on certain frequencies, there is sometimes an area where neither direct nor ionosphere waves are present. This sometimes happened when the early airplanes flew at low altitudes in mountainous terrain. For the high-altitude modern-day flights, there is no gap where the direct wave is insufficiently strong to produce intelligible signals and where the wave from the ionosphere is yet to be received.

As the airplane progresses away from the transmitting station, the direct wave grows weaker rapidly, and the only remaining transmission is that of signals received from the ionosphere. At this time the fading mentioned above is absent and the fading experienced is caused by the vagaries of the ionosphere as discussed in Chap. VIII.

The effectiveness of this ionosphere transmission is pictured on the graph of Fig. 165. The information on this figure is the result of a study between the ground stations of an aeronautical communication system. The station operators reported, hour by hour, the stations with which they were able to maintain satisfactory two-way communication (using voice). The curve shows conditions that existed for the case of extremely high ionic densities of August, 1937. It can be seen that at noon it was still possible to maintain satisfactory communication

with stations 200 miles distant, and communication existed for distances in excess of 1,000 miles during certain portions of the day. The communication conditions pictured in Fig. 165 were considered very poor. It is an axiom that communication between the airplane and the ground is always equal to or better than that between the ground stations; therefore, it can be seen that by means of the ionosphere the requirements for aeronautical communication previously discussed are met.

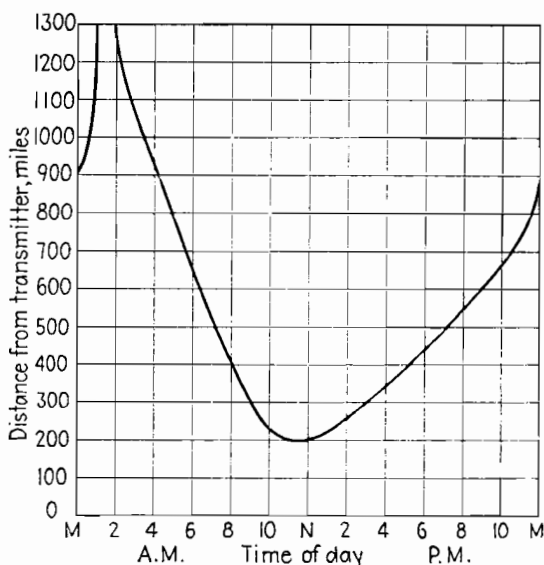

FIG. 165.—Distances over which two-way communications between aeronautical ground stations prevail for various times of day. This study represents the conditions that existed during Aug. 1 to Aug. 8, 1937.

Predicting the Behavior of an Ionosphere-propagated Wave.—

Methods for determining the field strength of a wave reflected from the ionosphere are now in the process of development but are not yet available; however, the ionosphere data published each month by the Bureau of Standards make possible the prediction of the behavior of an ionosphere-propagated wave and the selection of appropriate frequencies to be used for this type of communication. In order to do this it is necessary to consider the action of the gas layers upon a ray of energy which enters them.

It has previously been stated that this ray of energy from the transmitting antenna in passing through the ionized layer is bent back and returns to earth. This is not always the case, however, as the ray in some instances passes through the gas layer and travels outward through space never to return. There are three factors that determine whether the ray will return or whether it will pass through the layer. These are the ionic or electronic density of the layer, the frequency of the radio ray, and the angle of incidence made by the ray as it impinges upon the gas layer. It is the usual practice in discussing this subject

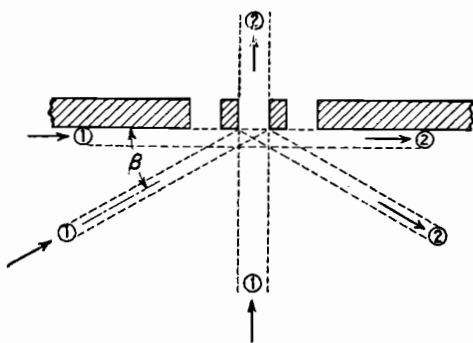

Fig. 166.—Action of a reflecting surface with angle of incidence for a given size of missile and surface opening. This illustration serves as an analogy portraying the relation between the density of the ionosphere layer and the wave length of the impinging wave upon the transmission and reflection of the wave by the layer.

to show the mathematics illustrating the principles just stated, but since the understanding of these mathematics by the communications engineer is not of prime importance, a crude analogy will be used instead. Referring to Fig. 166, a board with drilled holes of a certain diameter will be seen. The diameter of these holes relates to the ionic density of the gas layer, for if the diameter of these were very large, the entire board would be holes and its density that of air only. So with the gas layer, if there were but a few ions, the space would be unoccupied and all radio waves would travel through unimpeded. Also shown in Fig. 166 is a ball which is thrown at the board so that it strikes at various angles. The diameter of this ball is smaller than that of the holes. The diameter corresponds to wave length. If the ball is thrown at normal incidence to the surface of the board, it will

pass through it easily. When thrown at an angle B , the projection of the hole diameter is smaller than that of the ball, so it strikes the edge of the board and rebounds. If the ball is thrown at grazing incidence (parallel to the surface of the board), its progress will be unaffected by the presence of the board. In this

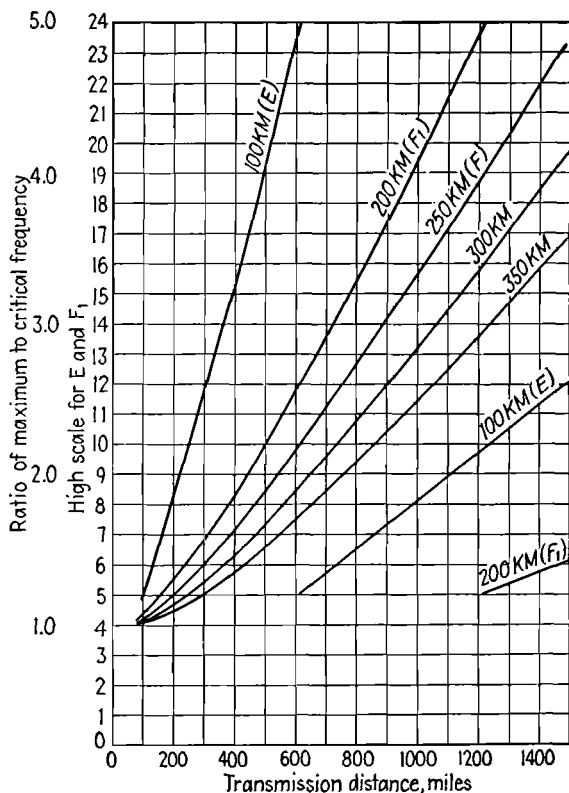

FIG. 167.—Ratio of maximum to critical frequency as a function of the distance between the point of transmission and point of reception for various ionosphere layer heights.

crude analogy it can be seen that not only are the relative diameters of ball and hole important, but the angle of projection also enters.

Referring to Fig. 164, it can be seen that frequencies higher than 3,750 kc. will pass through the E layer during the noon hour if this energy is projected at right angles to the layer, but at a smaller incidence angle, a higher frequency would rebound

from the layer. The conversion of the critical frequency at normal incidence to that at any angle may be done to a first approximation by multiplying the critical frequency by the secant of the angle of incidence.

For convenience in calculating, these factors are shown in Fig. 167 for various distances up to 1,500 miles and for layer heights of 100, 200, 250, 300, and 350 km. An example of the manner in which the chart may be used is illustrated by determining the highest frequency that may be used to transmit 1,000 miles via the *E* layer. The factor on the chart corresponding to a layer height of 100 km. and a distance of 1,000 miles is 8.15. Referring to Fig. 164, it can be seen that the critical frequency for the noon hour is 3,750 kc. This frequency times the factor previously referred to gives 30,600 as the maximum frequency. Frequencies higher than 30,600 kc. would "skip" and return to earth beyond 1,000 miles. This frequency would, of course, be of no use for communicating via the ionosphere at distances less than 1,000 miles.

The more usual problem in aeronautical communications consists in predicting the performance of a given frequency. This is done by dividing the frequency in question by factors taken from Fig. 167 for all layer heights and all distances. If the resulting frequency is numerically less than the layer frequency, it will be reflected; if greater it will pass through the layer. As an example, suppose that the performance of the 5,600-kc. frequency is to be predicted for a distance of 1,000 miles, then the data obtained from the curves previously referred to and calculated will be as shown in Table IV.

TABLE IV

Layer	Assumed height, km.	Factors for 1,000 miles	Modified frequency
<i>E</i>	100	8.15	688
<i>F</i>	300	2.85	1975
<i>F</i> ₁	250	3.38	1660
<i>F</i> ₂	350	2.5	2240

For ease of interpretation, the modified frequencies may be plotted on a curve showing the critical frequencies of the various layers. This is done in Fig. 168.

In Fig. 168 the modified frequencies are designated by prime letters corresponding to the layers to which they apply. Whenever the line marked with the prime letter is below the plot of the corresponding critical frequency, reflection is indicated. If, however, the plot of the modified frequency is above the critical frequency line, passage of the transmitted frequency by that layer is indicated and it can then impinge upon the next higher layer. Figure 168 thus indicates that from midnight to

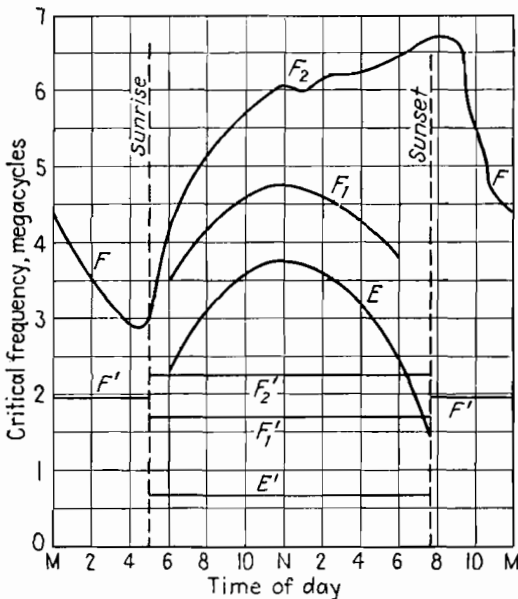

FIG. 168.—Method of predicting the performance of a 5,600-kc. frequency with time of day for a distance of 1,000 miles.

5:00 A.M. the wave would be successfully reflected by the then existing F layer. Between the hours of 6:00 A.M. and 7:30 P.M. the wave would be reflected by the E layer. It would also be reflected from the F_2 layer between 5:00 A.M. and 6:00 A.M. and between 6:30 P.M. and 7:30 P.M. It would not be reflected by this layer at other times, because the E layer would not allow the ray to penetrate so that it could be acted upon by the F_2 layer. The ray destined for the F_1 layer also would not be effective because the E layer would prevent it from reaching the F_1 layer. For a layer height greater than 350 km. and for

distances less than 1,000 miles, it can be seen that the F_2 layer would be quite effective.

The fact that a ray is reflected from a layer does not mean that it will be received with good intensity. The closer the transmitting frequency approaches the layer frequency, the greater will be the absorption. This accounts for the phenomena shown in Fig. 166. As the layer frequency approached the transmitting frequency, the latter was greatly attenuated during its transmission. There is no proved satisfactory method for making this calculation, but the absorption varies approximately as the square of the ratio of the transmitting and critical frequency. Also, the attenuation varies inversely with the angle of incidence between ray and layer. This is not because of absorption by the layer but because of absorption by the ground, since at grazing incidence the sky ray approaches the direct ray. This limiting angle is generally considered to be $3\frac{1}{2}$ deg.

It was early established that two frequencies—one near 3,000 and the other near 6,000 kc.—were required in order to maintain communication at all times and at distances between 200 and 1,000 miles. If the demand for 1,000-mile continuous communication is pressed, it will be necessary to add a third frequency in the vicinity of 8 megacycles.

The Aircraft Transmitting Antenna.—The character of the transmission has been discussed, and it is now necessary to turn attention to the mechanism employed for generating this transmission. One of the important factors in this mechanism is the aircraft transmitting antenna. The first antenna used for this purpose consisted of a long wire trailed below the airplane. To the end of this wire was attached a heavy weight so that the antenna would have a large vertical component. The other end of the antenna was attached to a reel, and resonance was produced by reeling out the correct amount of wire. An antenna of this type was reeled out to an electrical length of one-quarter or three-quarters wave length. It was often necessary to reel it out to the three-quarter wave-length point because the combined capacity of the fair-lead carrying the wire to the outside of the airplane and that of the reel was so high that only a short length of wire was needed to produce resonance, and most of the current from the transmitter returned via this high capacity, thereby making the *actual* antenna current low. This trailing

wire antenna had several disadvantages from an operating standpoint. The weight at the end of the wire was quite heavy (about 10 lb.). Also, the weights of the fair-lead and reel were appreciable. The aerodynamic drag was high and could not be tolerated with modern high-speed airplanes. The reason for removing this trailing wire antenna in the early days was, however, because of an operations problem. Since most of the airplanes were manned by a single pilot, the duty of remembering to reel in the antenna before landing fell upon him. With his many other duties, he invariably forgot to do this, thus creating a hazard both for the airplane and the people on the ground. The maintenance problem involved was also prominent when using this type of antenna.

The next antenna used in commercial practice was a mast made of streamlined aluminum-alloy tubing. For the purpose of suitably guying the mast and for furnishing necessary top capacity, a number of wires reached from the top of the mast back to insulators attached to the airplane's structure. Some of these masts had heights of as much as $7\frac{1}{2}$ ft. and were supported by three wires having lengths of 14 ft.

With the introduction of the high-speed transport airplane, it was realized that this type of antenna would have excessive drag. This type of flying equipment also marked the beginning of consistent flight under instrument conditions, which also meant icing conditions. The mast antennas were impractical under conditions of severe icing.

Two antennas with simple aerodynamic structures were worked out in answer to this problem. One of these was the short trailing wire developed by Transcontinental and Western Air Express. This consisted of a short wire trailing behind the airplane. No weight was attached to this antenna. This practice was in contrast with that previously described for the earlier trailing wire where an attempt was made to obtain a large vertical component. With this short wire the vertical component was not appreciable. No attempt was made to let out a given amount of wire. The wire was of a single length and attached to a tuning unit in the tail of the airplane. To this tuning unit was attached a transmission line from the transmitter. The antenna was not reeled in as no facilities for doing this were provided. The wire was allowed to trail behind the airplane at all times whether

in flight or on the ground. This wire was reasonably satisfactory, but a few disadvantages were assigned to it. Because it tended to transmit horizontally polarized waves, it did not produce good signal strengths when close to the station. The tuning units were not accurately adjusted, and the transmission lines to them were not correctly terminated, so the efficiency was not high. The maintenance problem was rather large. This antenna was removed from common use, however, due to the belief that it contributed to lightning strikes occurring to the airplanes. It is not in popular use today, but continues to constitute the best solution to the problem of a transmitting antenna for small craft.

The other antenna was a fixed structure worked out by United Air Lines. This structure consists simply of a wire connecting from a lead-in insulator near the nose of the airplane to another insulator attached to a short (6 in. approximately) mast located near the top of the vertical stabilizer. This type of antenna is in common use today.

Some experimental work has been done on the use of the wings of the airplane as a shunt-excited antenna. Such a radiator has proved itself to be successful; however, in order to do this it is necessary that a wire transmission line extend from the fuselage to the wing. For the low-wing airplane that is in extensive use by the airlines today, a wire of this type is not practical since it is in the way of the personnel responsible for servicing the airplane. The skew wire is also susceptible to icing.

Calculating the Characteristics of Aircraft Transmitting Antennas.—It is necessary that the characteristics of aircraft antennas be known in order to determine the transmitter power required, to predict the power that will be transferred to a given antenna by a transmitter, and to design the transmitter output and the communications receiver input circuits. These characteristics can, of course, be measured if the structure is already in existence, but for a new airplane existing only on the drawing boards of an airplane company's engineering department, even an approximate calculation is often helpful.

Referring to Fig. 169, a typical aircraft antenna is shown. This antenna has a length H , is at a mean distance h from the skin of the airplane, and is made of wire having a diameter d . The first step in this computation consists in calculating the

characteristic impedance. In order to do this it is necessary to calculate the capacity of the antenna by the following formula(8):

$$C = \frac{0.2416H}{\log_{10} (4h/d)} \quad (180)$$

The capacity given by this formula is in micromicrofarads, and it is assumed that $4h/H$ is equal to or less than unity.

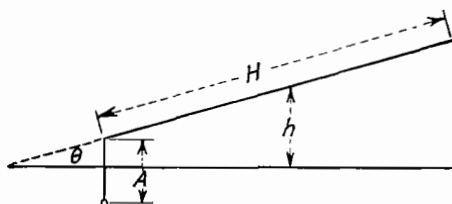

FIG. 169.—Diagram of typical nose to fin airplane antenna.

The inductance in microhenrys is given by(9)

$$L = 0.002H \left[2.303 \log_{10} \left(\frac{4H}{d} \right) - 1 \right] \quad (181)$$

The characteristic impedance may then be calculated from

$$Z_0 = \sqrt{\frac{L}{C}} \quad (182)$$

In this formula it is necessary that inductance and capacity be in henrys and farads, or microhenrys and microfarads. The lengths and diameters of Eqs. (180) and (181) are in centimeters.

It must be recognized that the structure of the airplane adds a conducting vertical member in the form of the vertical stabilizer to the antenna shown in Fig. 169. The presence of this conducting member may be accounted for by considering the capacity and inductance of the antenna wire to the vertical stabilizer separately and adding these resulting constants to those obtained when the fuselage of the airplane was considered alone.

The radiation from a transmitter produces standing waves on the antenna. These standing waves will have a wave length that is a function of the velocity of propagation of the radio wave on the antenna. Because of radiation and attenuation, this velocity will be less than that in air. In order to determine

the natural frequency (quarter-wave value) or that value when the reactance at the base of the antenna is zero, it is only necessary to convert the length of the antenna to meters, then convert to kilocycles by using the following expression:

$$F_0 = \frac{V}{4H} \quad (183)$$

In this expression, H is the total length of the antenna in meters and V is the velocity of the radio wave on the wire as obtained from the following empirical formula(10):

$$V = 300,000 \left(1 - \frac{2,680}{Z^2_0} \right) \quad (184)$$

The radiation resistance may now be computed for any frequency less than this natural frequency by an additional series of calculations. First compute the value K from

$$K = \frac{1}{\sin \theta + \cos \theta} \quad (185)$$

In this expression, θ is the angle between the antenna wire and the fuselage as shown in Fig. 169.

Then calculate a' from

$$a' = KH \sin \theta \quad (186)$$

In Eq. (186) the length H may be expressed in any unit desired provided that the same type of unit is used throughout the computation. Compute the total value of the quantity a by adding to it the length of the vertical leadin (see Fig. 169):

$$a = a' + A \quad (187)$$

Compute the auxiliary quantity b from

$$b = KH \cos \theta \quad (188)$$

Compute P from

$$P = \frac{b}{a + b} \quad (189)$$

Compute the value of F_0/F for any desired frequency F , and obtain the value of radiation resistance directly from the curve(11) of Fig. 170.

For frequencies higher than the natural or quarter-wave frequency the radiation resistance may be computed from(12)

$$R = 15 \left[-\frac{\pi}{2} \sin \frac{4\pi H'}{\lambda} + \left(2.303 \log_{10} \frac{2H}{\lambda} + 1.722 \right) \left(\cos \frac{4\pi H'}{\lambda} \right) + 2 \left(2.415 + 2.303 \log_{10} \frac{2H'}{\lambda} \right) \right] \quad (190)$$

In this expression, the symbol H' is used to denote the length of the antenna plus leadin. The units used for H' must correspond to those used for the wave length.

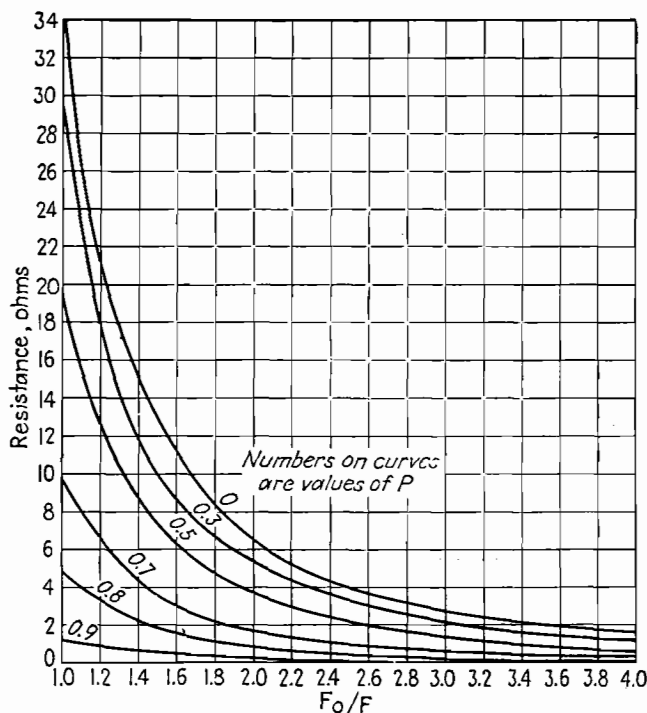

FIG. 170.—Resistance of antennas as a function of the ratio between fundamental and lower frequencies for various values of the auxiliary quantity P . (From Peirce, *Electrical Oscillations and Electric Waves*.)

The reactance of the antenna may be determined by calculating, first, two auxiliary quantities. The first of these is the equivalent resistance calculated from

$$r = \frac{4R}{1 - \frac{\sin(4\pi H'/\lambda)}{4\pi H'/\lambda}} \quad (191)$$

The attenuation constant may then be computed from

$$\alpha = \frac{r}{2Z_0} \quad (192)$$

With these two quantities known, the reactance at the base of the antenna may be calculated from

$$X = Z_0 \frac{\sin\left(\frac{4\pi H'}{\lambda}\right) + \frac{\alpha}{4\pi H'/\lambda} \sinh \alpha}{\cosh \alpha - \cos\left(\frac{4\pi H'}{\lambda}\right)} \quad (193)$$

Electrical Characteristics of Aircraft Transmitting Antennas.

Typical curves of reactance and resistance of aircraft antennas are shown in Fig. 171 for the Douglas model DC-3 and in Fig. 172 for the Douglas model DC-4 airplanes. Referring to Fig. 171, it can be seen that the natural frequency of this antenna is about 5,150 kc. At this point it does not have the radiation resistance of a quarter-wave vertical antenna, for its total resistance is only 3.8 ohms. At a frequency of 3 megacycles the resistance is only 0.8 ohm. This is the combined radiation and ohmic resistance. Within the range of 3 to 6 megacycles it can be seen that there is only one frequency for which the antenna is nonreactive.

The DC-3 is an airplane having a provisional gross weight of about 25,000 lb., whereas the provisional gross weight of the DC-4 (the antenna characteristics of which are shown in Fig. 172) was 65,000 lb. It can therefore be seen that the DC-4 was a much larger airplane than the DC-3 and the antennas were correspondingly greater. The DC-4, however, had a three-part rudder, so the height of the antenna was not much greater than that for the DC-3. Referring to Fig. 172, it can be seen that there were two frequencies in the range of 3 to 6 megacycles for which the antenna was resistive. One of these was a resonance point, and the other may be called an antiresonance (parallel resonance) point.

The resistance of this antenna at its natural frequency was about 5 ohms. This natural frequency resistance is higher

than for the DC-3 antenna, but more important, it occurs at only 3,300 kc. The resistance at the antiresonance point is high and reaches a measured value of approximately 10,000 ohms. It can also be seen that another resonance (three-quarter wave) point is reached by this antenna at about 8.8 megacycles. Antennas with characteristics similar to those shown for the DC-4

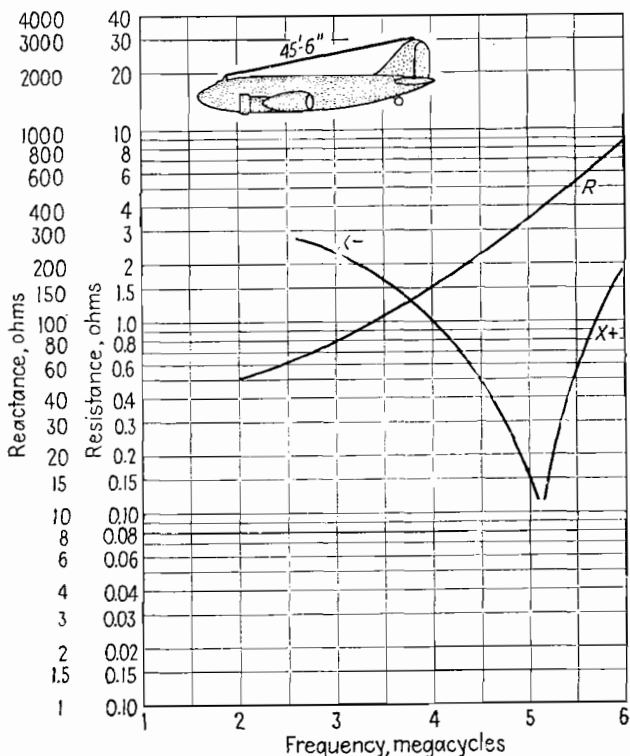

FIG. 171.—Electrical characteristics of transmitting antenna on Douglas Model DC-3 airplane.

are uncommon in this country, and until airplanes of the size of the DC-4 come into extensive use, it can be said that low-resistance values in the communications range of frequencies characterize the airplane transmitting antenna.

The airplane antenna in some respects represents an ideal. It is located away from all dielectric obstructions. The ground system is a perfect conductor, and the only loss (as far as energy

in the antenna is concerned) is the dielectric of the lead-in and rear-support insulators. These insulators can be so designed that their losses are not appreciable. The airplane antenna can be considered a highly efficient device. The truth of this statement was borne out in practice when it was found that some airplanes, equipped with antennas having such small effective

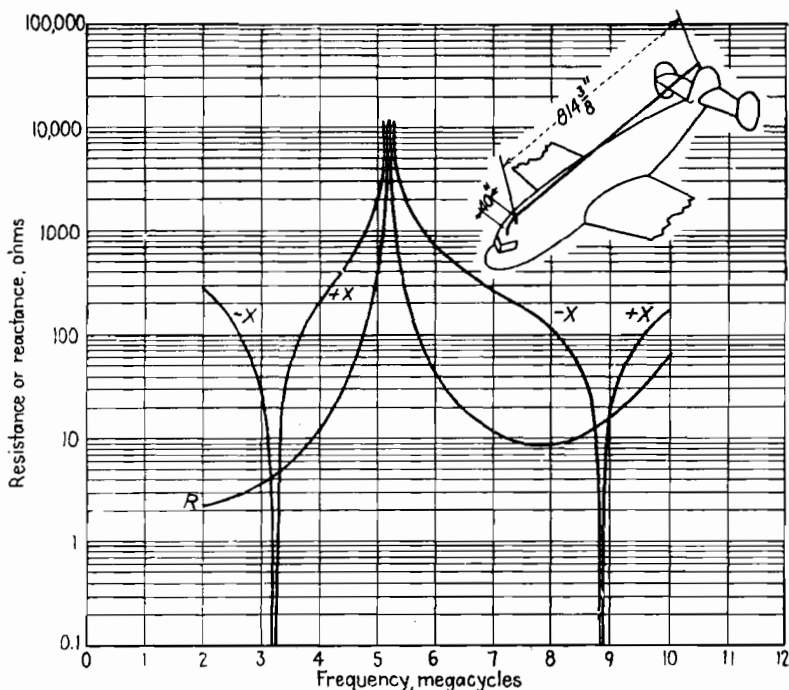

FIG. 172.—Electrical characteristics of transmitting antenna on experimental model of Douglas DC-4 airplane.

heights that they could hardly be considered much more than unterminated but otherwise conventional transmission lines, have radiated usable signals.

Space Patterns of Aircraft Communications Antennas.—Since the airplane is not a symmetrical body, transmission from it may have directional patterns. As far as is known, all the best methods for determining these patterns are experimental. One process consists in flying the airplane in circles about a point and recording the relative field strength received on the ground. A better method(13) consists of constructing small models and

equipping them with ultra-high-frequency oscillators. By using the principle of similitude it is possible to determine, with a small model and ultra-high frequencies, the performance of a full-scale antenna with medium frequencies.

If the antennas have appreciable vertical components, the patterns tend to be nondirectional. The trailing wire which projects directly back from the tail of the airplane emits hori-

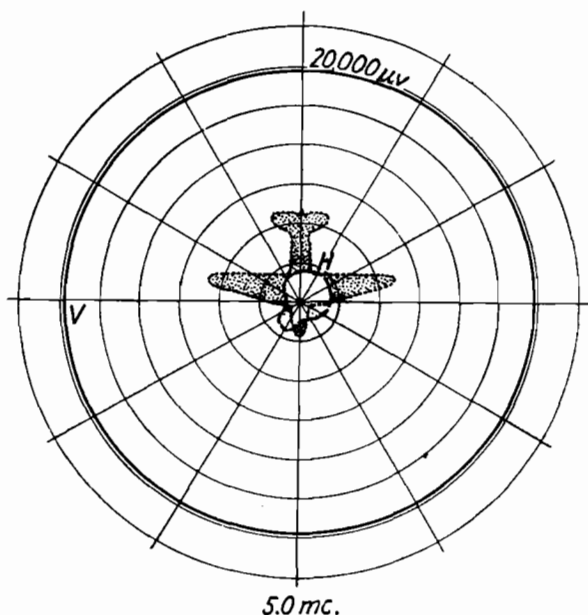

FIG. 173.—Horizontal-plane field pattern of a transmitting antenna on a small airplane. The dotted pattern is for the horizontally polarized and the solid pattern is for the vertically polarized components. Transmitting frequency is 5 megacycles. (Courtesy of U.S. War Department, A.R.L.)

zontally polarized waves in a directional pattern. The trailing wire with a weight emits an essentially nondirectional signal. The directive pattern may change with frequency. The characteristics of a fixed antenna mounted on a small airplane are shown in Figs. 173 and 174. This antenna consisted of a vertical mast 50 in. in height and a 15-ft. horizontal section mounted over the airplane. The directional patterns for both horizontally and vertically polarized radiation with a frequency of 5 megacycles are shown in Fig. 173. It will be seen that the greater

portion of the transmission is vertically polarized and nondirectional. A certain nonsymmetrical horizontally polarized component is present but has a magnitude which is only 16 per cent of that of the vertically polarized field strength. When the frequency of this antenna was increased to 10 megacycles, the field pattern changed greatly as is shown in Fig. 174. The horizontally polarized component became large and had an

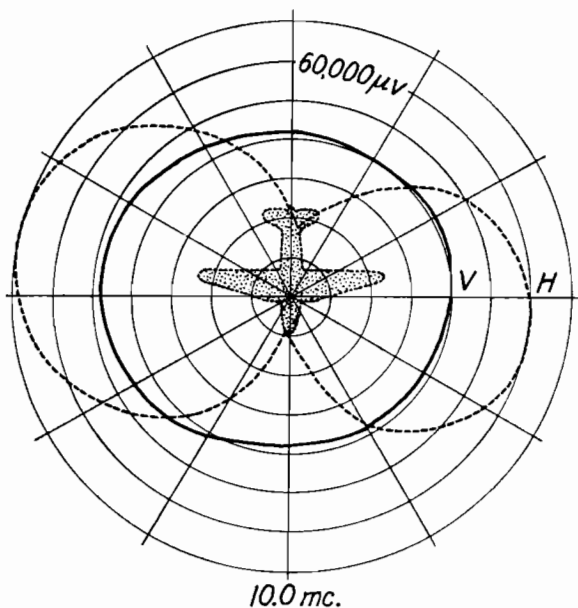

FIG. 174.—Horizontal-plane field pattern of the antenna of Fig. 173 with a transmitting frequency of 10 megacycles. The dotted pattern is for the horizontally polarized and the solid pattern is for the vertically polarized components. (Courtesy of U.S. War Department, A.R.L.)

essentially figure-8 pattern. The vertically polarized component decreased with respect to the horizontally polarized component. It now has a field strength that is 33 per cent less than the maximum of the horizontally polarized component although it continues to have a nondirectional configuration.

Aircraft-transmitter Output-circuit Design.—The low values of resistance that characterize aircraft transmitting antennas make necessary special output-circuit-design consideration. The problem involved is pictured in Fig. 175. In this picture a generator having a pure internal resistance which exactly

matches the external load is connected to an antenna. The antenna has a reactance of X_a and a resistance of R_a . It is necessary that the antenna reactance be canceled, so a reactor is added in series with the antenna. This reactor has a reactance X_0 which exactly matches X_a in magnitude but with opposite sign. Because X_0 is imperfect, it also has a resistance R_0 . The generator delivers all its power into R_0 and R_a , but the power delivered to the reactor is lost to the antenna. If the total output power from the generator is P_0 , P_1 is the power lost in the reactor, and P_a is the power delivered to the antenna, then the following equation can be written:

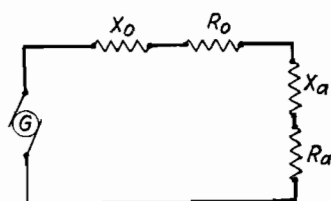

FIG. 175.—Electrical representation of the output circuit of an aircraft transmitter.

$$P_0 = P_1 + P_a \quad (194)$$

also

$$\frac{P_1}{P_a} = \frac{R_0}{R_a} \quad (195)$$

The efficiency will then be

$$\text{Eff} = \frac{P_a}{P_0} = \frac{P_a}{P_1 + P_a} \quad (196)$$

Substituting Eq. (195) in Eq. (196) the following results:

$$\text{Eff} = \frac{R_a^2}{R_0^2 + R_0 R_a} \quad (197)$$

If the ratio of reactance to resistance in the series reactor is Q , then

$$Q = \frac{X_a}{R_0} \quad (198)$$

or

$$\text{Eff} = \frac{R_a^2 Q^2}{X_a^2 + X_a R_a Q} \quad (199)$$

A figure of 300 represents an unusually high value of Q , but if this value is assumed and the values of reactance and resistance are obtained from Fig. 171 for the 3-megacycle frequency, an efficiency of only 53 per cent is calculated. This does not mean that the efficiency of the output stage is 53 per cent, for this value is the efficiency of the output circuit alone. This means that if a transmitter is rated to have an output of 100 watts

into a quarter-wave antenna, with a resistance of approximately 33 ohms, it will put only 53 watts into an aircraft antenna having the characteristics depicted in Fig. 171 (at 3 megacycles). As has previously been stated, a transmitter with the performance just described would be very well designed.

Because of the problems just discussed it is necessary that every effort be made to keep the output circuit free from extraneous resistance. As a result, the common aircraft-transmitter output circuit presents a simple configuration. This configuration, almost universally used, is shown on Fig. 176. A coil provided with taps acts as an autotransformer in order to produce the correct value of load for the output vacuum tube. One end of this coil is connected to ground via the by-pass condenser C_B . This practice permits the introduction of plate voltage without the necessity of using a parallel choke. In series with the other end of the coil is another condenser C_A which serves either one or two purposes. It serves to keep high direct-current voltage from the antenna where (in case of a broken antenna) it might cause

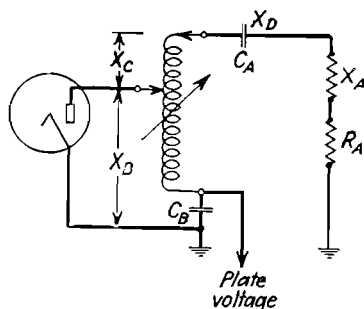

FIG. 176.—Schematic diagram of an aircraft transmitter output circuit.

damage to the skin of the airplane and where it would always be a hazard to personnel working near the equipment. In addition, this condenser sometimes acts to cancel out the positive reactance of the antenna (such as for frequencies above 5,150 kc. on the DC-3 antenna). Although the antenna reactance may not be positive, it is often necessary that condenser C_A add negative reactance so that X_B may be made large enough to provide the necessary output tube load. Adjustment for resonance is usually made by first moving taps on the antenna coil, then making small inductance adjustments such as are provided by coupling a short-circuited turn to the coil or varying a contact on three coil turns.

If the correct load for the output tube is Z_0 , then

$$Z_0 = \frac{X^2_B}{R} \tag{200}$$

In this expression, X_B is the reactance of the coil as pictured in Fig. 176 and R is the total series resistance, that is, the resistance of the coil and antenna, or

$$R = R_c + R_A \quad (201)$$

It is assumed that the condensers do not introduce appreciable resistance. Again using Q as the figure of merit of the coil,

$$Q = \frac{X_B + X_C}{R_c} \quad (202)$$

Substituting Eq. (202) in Eq. (201),

$$R = \frac{X_C + X_B + R_A Q}{Q} \quad (203)$$

Substituting Eq. (203) in Eq. (200),

$$Z_0 = \frac{X_B^2 Q}{X_C + X_B + R_A Q} \quad (204)$$

but

$$X_C + X_B + X_D = X_A \quad (205)$$

So, substituting Eq. (205) in Eq. (204) and solving for X_B , the following results:

$$X_B = \sqrt{\frac{Z_0}{Q} (X_A - X_D + R_A Q)} \quad (206)$$

Equation (206) gives all the parameters necessary for designing the circuit of Fig. 176.

Shunt capacitors across the antenna are to be avoided since they serve to reduce the effective series capacity of the antenna. It is, however, necessary to add such capacitors when the antenna assumes high reactance or resistance values such as those that occur near the antiresonance point of the DC-4 antenna.

Figure 177 shows such a condenser having a reactance $-jX_S$ shunting an antenna having a reactance X_A and a resistance R_A . This has the effect of altering the resistance and capacity so that the virtual reactance of X'_A now replaces X_A and R'_A

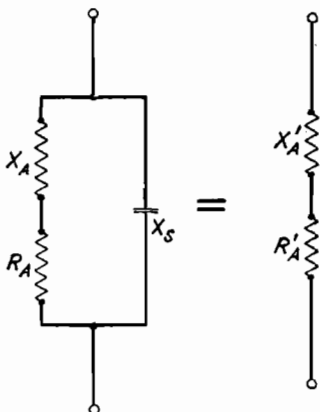

FIG. 177.—Effect of shunting a condenser across the terminals of an antenna.

replaces R_A . It can be shown that

$$R'_A = \frac{R_A X_S^2}{R^2_A + (X_A - X_S)^2} \quad (207)$$

and

$$X'_A = \frac{X_A X_S^2 - R^2_A X_S - X^2_A X_S}{R^2_A + (X_A - X_S)^2} \quad (208)$$

When shunt capacitors are used, they are arranged to connect to the antenna only on those occasions when the frequencies where the antenna presents high impedance are in use.

Aircraft-transmitter Frequency-changing Methods.—It has previously been stated that it is common practice to use two frequencies because of the changing ionosphere. Early transmitters were designed with two-frequency operation as a requirement; however, later practices in air transportation have modified this requirement. Because of the large amount of message traffic, it has been necessary to limit the length of airline using one set of frequencies. That is, a line 1,000 miles or less in length will use a given set of frequencies, and the next section of line will use a different set. In the early days, airplanes were changed often as a flight proceeded across the country, so the problem of changing communications frequencies consisted in merely furnishing the outbound airplane with equipment having the proper frequencies. Naturally a switching problem was involved in changing from the lower to the higher frequency, but this problem was comparatively simple. With the coming of modern airplanes a single craft completes more than a 2,000-mile trip and stops only for gasoline and for loading passengers and cargo. The necessity for changing radio equipment during stops is very undesirable because of the short time available. Modern airplanes have also introduced another factor. They often fly over a terminal point because of bad weather and operate into the next frequency division. On these occasions it is necessary that they be equipped with the appropriate frequencies. As a result of these factors, transmitters are being designed for 10 frequencies (five sets) and some of the airlines could well use 12 or 14.

Because the requirements for low weight and small space are always present, this frequency-changing problem has made some ingenious solutions necessary.

As has already been discussed, one of the first methods was the use of switches. The Boeing-type transmitter was an example of this means of providing for two frequencies. This method was also used in the Western Electric 13-type which was marketed in 1933 and provided three frequencies. Separate tuning elements were provided throughout the 13-type, and a series of three-point switches selected the appropriate set of elements. It can be seen that the necessary leads required to select 10 frequencies with this method would make the system impractical. One of the next methods evolved was the use of a "turret." This method was used in the Western Electric ATR transmitter, designed in 1936 and 1937, and it is also incorporated in their later models. In this equipment a wheel of rather large diameter mounted all the tuning elements. Beginning near the hub of the wheel, the crystals were mounted, followed by the intermediate stage tuning coils, and with the output circuits near the rim. No wire connections were provided to these various circuit elements. As the wheel rotated, pins attached to the elements made contact with spring clips connecting to the tubes, etc. The Bendix Company used a somewhat similar arrangement in some of their transmitters; however, the turret is horizontal, and only one set of elements is present in one wheel diameter. That is, one wheel has all the output circuits, the next the intermediate stage elements, and the next the crystals, etc. These wheels all have the same diameter and are mounted on a common rotating shaft.

A method differing entirely from those described was developed by Collins in their Autotune system. In this system a *single* set of tuning elements is used, and these elements are varied by a cam arrangement to the proper setting for each frequency. In the turret system there are 10 sets of tuning elements; therefore, a weight increase of only 1.6 oz. per set means a weight increase of 1 lb. in the transmitter. This is not true of the Collins type of control. It is believed that the possibilities of the Autotune method have not been fully explored, and a system based on this principle, if the cam mechanism weight can be made low, offers the best possibility for the transmitter of the future.

Other Considerations in Aircraft-transmitter Design.—In designing the early transmitters an effort was made to provide as much power as weight limitations would permit. This

resulted in a power of 50 watts. With advances in the electronic art, however, the modern transmitter has a power output of 100 watts. A transmitter designed in 1937 utilizing an alternating-current power supply had an output of 250 watts, and it is believed that, in the future, aircraft transmitters with output power of 200 to 300 watts will be common.

Early in the art it was found that only a transmitter with crystal-controlled frequency would provide satisfactory communication. This led to much development in crystals, which at that time were considered largely as laboratory curiosities rather than practical apparatus units. This development resulted in a crystal clamped at its extremities by raised edges on the crystal-holder plates. Several small temperature-controlled ovens for these crystals were also developed but were made unnecessary with the later development of the zero-temperature coefficient crystal cut.

Simplicity in the method of intermediate-stage tuning is very desirable. Simple tuning elements usually mean low weight and also lowered maintenance. The Western Electric 13-type transmitter employing two interstage transformers made use of band-pass filter design, and no tuning was necessary. One of the transmitters used interstage coils adjusted merely by manually removing turns, thus eliminating tuning adjustments.

The weight of aircraft transmitters must be as low as possible. Since their weight will, in general, be higher than that of receivers, an effort should be made to divide the transmitters into sections so that each section will not weigh more than 50 lb. This is a necessary requirement in order that the unit may be easily handled by one man in a narrow airplane companionway. Although this requirement is very important, it has not always been adhered to. One transmitter producing 100 watts has a weight of 42 lb. exclusive of power supply. The 250-watt transmitter previously referred to had a weight of 80 lb. including the power supply. One of the modern equipments combining transmitter, receiver, and power supply in a single unit has a weight of 75 lb. This latter unit is very economical in weight but subjects the personnel who must handle the equipment to an inconvenience.

The Aircraft Communications Receiver.—As important as emitting a satisfactory signal from the aircraft is the ability to

read the answer from the ground station. This problem has necessitated a receiver of special design.

Like the transmitter, the modern receiver is also equipped with 10 frequencies. The frequency-changing mechanism is usually connected directly to the transmitter so that the receiver changes frequency whenever the transmitter changes. Since component sizes are smaller in the receiver than in the transmitter, the usual method for frequency selection consists of the rotary switch; however, in the combined receiver-transmitter previously mentioned, the turret system is used.

The demand for the automatic-gain-control system is unusual. When an airplane is about to begin its flight, it is necessary to contact the local radio station. During this time the field strength will be very great, but as the flight progresses 200 miles, the field strengths will be much lower. It is necessary, therefore, that the output of the radio receiver be constant for input voltages of $1 \mu\text{v}$ to 1 volt. It is very undesirable that the pilot manipulate a gain control in order to compensate for changing field strengths, because if he turns the control to the low position for comfortable reception from a local station, a weaker station would not be able to attract his attention. As a corollary, it follows that such an excellent automatic gain control must have a carrier-controlled output suppressor. This feature is necessary because the automatic gain control would serve to greatly increase receiver gain during the time that no carrier is present, and under conditions of high atmospherics the noise would be unbearable.

The long-range automatic gain control is usually achieved by a two-part circuit. One portion of the circuit is more or less conventional, whereas the second circuit consists of a gain spoiler in the form of a diode connected across the grid circuit of the first tube. This diode is biased to some predetermined value, so that when the input voltage exceeds a certain value, it begins to conduct and lowers the impedance across the grid of the first tube, thereby lowering the gain of the first stage. There is at present no entirely satisfactory carrier-controlled output suppressor incorporated in aircraft receivers. The simpler types of control are responsive to static, so it is necessary to set them to a predetermined threshold of operation. This practice is undesirable because it prevents reception of weak

signals. The type employing additional oscillators, filters, etc., appears too involved to be satisfactory for aircraft use.

The receivers are of the superheterodyne type and use crystal-controlled oscillators. The use of a crystal in the transmitter and receiver gives nearly as much assurance that reception and transmission will be on the same channel as if a copper connection were used between the telephone instruments.

Because of the crowded channels it is necessary that the selectivity of the receiver be such that the response is down 40 db for a band width of 12 kc. (Frequencies in this communications band are allocated with a 6 kc. spacing.) Image-frequency responses are specified at between 70 and 80 db down.

Signal-to-noise ratio must be very good because the receiver is often used to receive very weak signals. This value is specified as 6 db with input signals as low as 1 μ v of carrier modulated 30 per cent.

Audio requirements are not high for this receiver because it is used for voice work alone. A response that is flat within 4 db for frequencies between 300 and 2,500 cycles is sufficient. The total harmonic distortion of the audio system should not exceed 5 to 10 per cent for 30 per cent modulated carriers with values up to 0.1 volt and not more than 20 per cent between 0.1 and 1 volt.

The complete weight of the receiver and power supply for a 10-frequency receiver is about 30 lb. This weight is for a receiver fully equipped with 10 pre-set frequencies operating in the range from 2 to 10 megacycles.

Characteristics of Ground-station Transmitters.—When the first ground-station transmitters were placed in service, they were equipped for only single-frequency operation. Later this was changed to allow for quickly shifting to any one of four frequencies. With the coming of newer equipment, means were provided for rapid selection of any one of 10 frequencies. The latest equipment, however, is arranged for only two or three frequencies. The considerations involved in determining the correct number of frequencies to be incorporated in ground-station transmitters are worthy of study. As has previously been stated, two or more frequencies are required because of ionosphere characteristics, so this frequency set (two or three) is the minimum required. As the number of flights over an

airline increases, the point is reached where the traffic cannot be handled by a single set of frequencies and so a second set is added. A point (usually a major terminal) is selected and becomes the frequency-division point; that is, the frequencies used on one side of the point belong to one set and those used on the other side belong to the second set. The number of contacts between ground stations and an airplane on a given frequency is, to a first approximation, a function of the length of the frequency division. Thus, the total number of contacts handled by a set of frequencies is proportional to the product of frequency-division miles and the number of airplanes scheduled to fly over those miles. It follows, then, that if one set of frequencies will take care of the traffic over a frequency division X miles in length over which N airplanes fly then another set of frequencies will take care of the traffic over a division $2X$ miles in length over which $N/2$ airplanes fly. The total time that a radio operator is busy, however, is not in proportion to the time that a frequency channel is occupied. This is because a radio station is responsible for contacts from an airplane half way from that station to those adjoining it on both sides. Since the distance between radio stations is approximately the same, the time of the operators is utilized in proportion only to the number of airplane schedules. That is, a radio operator at a terminal station is only half as busy (in so far as his radio-contact duties are concerned) as an operator at an intermediate station. This is because schedules extend to only one side of a terminal station, whereas they extend to both sides of an intermediate station. A radio station on a division $2X$ miles in length with $N/2$ schedules is only half as busy as a station handling a division of X miles with N airplanes scheduled over it. If a frequency-division point is so located that the same number of schedules operate over both sections and one operator can handle this number of schedules, then the transmitter should be equipped with two sets of frequencies. If, however, the division is made at a point so that the number of miles to one side of the point is $2X$ with $N/2$ airplanes and to the other side X with N airplanes, then the frequency channels will be equally utilized, but the radio operator should be able to handle another frequency division having $N/2$ schedules, and three sets of frequencies may well be included in the transmitter. As the

air-traffic business grows and the number of schedules is increased, the frequency divisions become shorter. An operator at this time can handle only one set, another operator being required to handle the additional frequencies. At this time the equipment with more than one set of frequencies is of no value.

The foregoing discussion, then, serves to explain the change in transmitter requirements with time. First, the frequency channels became saturated, and when the division was split, time became available for the radio operators. Upon further increase in schedules, the station time as well as the channel time became saturated. Thus, at the intermediate stage a multifrequency transmitter was required, but with further increase in business, a multimanned station was needed.

The method of providing multifrequency operation also varied with time. The earlier equipment consisted merely in providing a series of switches located throughout the transmitter and actuated by a number of cams and push rods. The switches were connected to taps on inductors or connected various condensers to coils, etc. The later type shift did not differ greatly in principle but was a tremendous improvement mechanically. All the switches were arranged in an orderly fashion and were actuated either by a single rotating rod or a series of parallel push rods. The latest innovation in multichannel transmitters is a radical departure from the systems used on aircraft and those just described for ground stations. Each channel consists of a transmitter complete in all respects except that it is not equipped with a power supply or an audio modulator. Switching frequencies merely consists in turning on the filament power to the desired channel. Such a method is particularly satisfactory for use with high-powered transmitters because the necessity for switching large voltages becomes a difficult problem. The solution described is made possible because of the comparatively low power-tube complement cost that is in vogue today.

All the earlier transmitters were operated locally. That is, they were usually located adjacent to the radio operator's position, but because of interference to receivers located on the airport and the difficulties involved in making suitable antenna installations at the airport, the practice of locating transmitters at a distance from the point of operation has been introduced. An attempt is made to keep the transmitter within 2 miles

of the airport, but at some of the larger terminals the transmitters have been located as far as 15 miles away due to the difficulties arising in securing proper sites. Control of the transmitter is usually accomplished with a telephone-dial system over the pair of wires also used for conveying the audio-modulating frequency.

The first ground stations in common use had a power output of 400 watts. This figure was chosen as a compromise among several factors. One of these factors was economy. Airlines maintain a comparatively large number of ground stations (as many as 40 for large airlines); hence, any tube-complement cost must be multiplied by the total number of stations. At the time that the early ground stations were designed, a 400-watt station constituted peak economy.

The most desirable power would be that which would allow communications between the terminals of the airline and to the airplanes at all times. Such a requirement, as was previously discussed, cannot be met by power alone; hence sufficient power is provided (consistent with economical considerations) to allow communications when atmospheric noise is high but with ionosphere conditions permitting. Experience has shown that 400 watts was not sufficient to accomplish this at all times. As the cost of vacuum-tube complements decreased, transmitters were constructed employing 1,000, 2,500, and 5,000 watts. The new power figures were chosen because they represent economical designs. The figures of 1,000 and 2,500 watts represent minimum powers that could be secured with minimum large-tube complements, whereas 5,000 watts represent a field-strength gain of 11 db, the approximate increase that broadcast (entertainment) stations have always considered the minimum necessary in order to produce a noticeable improvement. The transmitters employ crystal control, and, besides an oscillator, one or two intermediate stages of power amplification are necessary to drive the output tubes.

One of the problems that must be considered in designing ground-station transmitters is that of interference between adjacent channels. In the days before the practice of locating transmitters remotely came into general use, as many as 10 transmitters were often located around the airport, with separations between them of not more than one mile. If these trans-

mitters were allowed to overmodulate, they would produce spurious frequencies that fall in the adjacent bands. It is desirable that the transmitters be allowed to modulate completely in order that their efficiencies be greatest; therefore, it is necessary that a constant-level input amplifier be incorporated between the microphone and the transmitter. Such an amplifier had best include two sections. One of these sections should

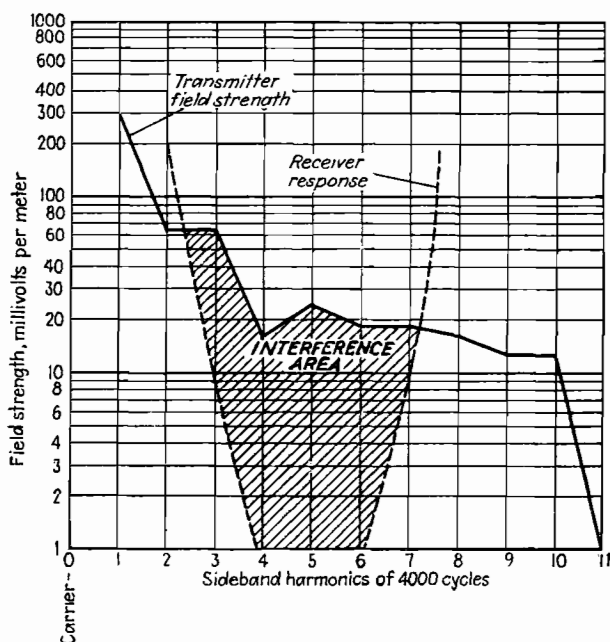

Fig. 178.—Audio distortion from aeronautical ground-station transmitter causing interference on adjacent channels.

have a slow time constant so that distortion will not occur by reason of too rapid gain change, and a second section should be rapid in its actions but should act only to cut off excessive audio peaks.

Even though a transmitter has comparatively low audio-harmonic distortion, the audio-frequency side bands generated by this distortion will fall in adjacent channels and will have signal intensities sufficient to produce disturbances. This phenomenon is pictured(14) graphically in Fig. 178. The higher the order of the fundamental frequency, the greater will be the

disturbance because a lower order harmonic will fall in the adjacent channel. As an example, suppose that the distortion of a transmitter is the same at all audio frequencies and that the second harmonic has a field strength value sufficient to cause disturbances in the adjacent channel, then when a 1,000-cycle note is present in the input, the 2,000-cycle harmonic will not cause a disturbance in a channel separated by 6 kc. The same will be true of a 2,000-cycle note producing a second harmonic of 4,000 cycles, but a 3,000-cycle note will have its second harmonic exactly in the adjacent band. The solution to this problem consists of connecting a low-pass audio filter in the circuit beyond the point where all audio amplification has taken place but before the point where modulation occurs. Such a filter may have a cutoff frequency of 3,500 cycles and not appreciably affect the quality of the transmitted speech, or it may have a cutoff frequency as low as 2,500 cycles for severe cases.

Another unusual phenomenon that has occurred in ground-station installations, which also concerns interference, is the generation of a single spurious frequency due to cross modulation between transmitters located adjacent to each other. Where two transmitters are located so that coupling exists between the antennas associated with them, and they employ slightly different frequencies, the second harmonic of one transmitter will modulate the second transmitter and produce a high field-strength signal of a frequency different from that assigned to either of the generating transmitters. The relation between these frequencies is such that the spurious frequency often falls in a band assigned to another service. Frequencies generated in this manner have been known to cause interference to services located more than 500 miles from the generating transmitters. The solution lies, of course, in decoupling the transmitters. This can be done either by moving the antennas apart or installing suitable wave filters. The proper solution is that which is most practical. If the frequency spacing is low, the filter may not be practical; on the other hand, if property allowing sufficient spacing between antennas is not available, filters designed with great care must be incorporated in the equipment.

The Ground-station Receiver.—The considerations involved in determining the proper number of frequencies to be incorporated in a ground-station receiver are quite different from those

involved in making the same determination for a transmitter. Although an operator needs to use his transmitter only when his station must make a transmission, it is necessary for him to know at all times when a channel is being used and, during the greater portion of the time, what is being said on the channel. It is not possible for him to shift from channel to channel because in so doing he may miss a call. If two or more channels are to be covered simultaneously, then it is necessary that two or more receivers be used. Thus, it is seen that one set of frequencies constitutes the most practical receiver design. This conclusion, however, requires some modification because of recent traffic conditions that have made mandatory the use of frequencies in combinations other than a set. Under these conditions, a certain number of contacts are made on the frequency opposite from that in regular use. This does not warrant the use of two single-frequency receivers, but the frequencies can be covered by arranging a receiver so that it can receive both frequencies simultaneously. This process is sometimes extended so that as many as six frequencies can be received simultaneously, but it is to be emphasized that this kind of operation appears to be consistent only with a transition period, after which a more regular operation will require reception on only one frequency.

Like the aircraft receiver, the unit for the ground station is of the superheterodyne type and its oscillators are controlled by a crystal. The method for accomplishing multifrequency operation is different from that used in the aircraft equipment because weight and space considerations are not of prime importance. The usual method consists in using separate radio-frequency amplifiers and separate first detectors and oscillators for each channel. The outputs from the second detectors are connected in parallel to the input of a common intermediate-frequency amplifier system, which in turn connects to a suitable second detector, automatic-gain-control system, audio amplifier, etc. The selection of the desired frequency (or frequencies) is accomplished by merely applying plate power to the proper set of radio-frequency amplifiers, oscillators, and first detectors.

Because of the noise generated by electrically operated maintenance equipment located at the major air terminals, and because of the low field-strength signals, it is necessary that the ground-station receivers be located at a distance from the

operations room. The usual practice consists in finding a quiet receiver location after making noise measurements lasting over a period of one month. For reasons of economy an attempt is made to find such a location as close to the airport as possible. The receivers are then installed in this location, and their output is brought to the airport over telephone lines rented from the local telephone company. This method of receiver installation makes it possible to locate the radio operator at the scene of operation and still provides for quiet reception. The control of the gain of the receiver (if not entirely automatic) and the selection of frequencies are accomplished by a telephone dial operating a stepping switch.

A local receiver is also provided. This receiver is for use in case of failure of the telephone lines or the radio receiver associated with them. In order that this receiver may provide effective reception in the presence of the transmitters operating near the airport, it is sometimes necessary to make special provisions in the design of the receiver. One of these precautions is the provision for filters in all the lines that connect to the receiver from external points. These filters assure that all the radio-frequency energy coming to the receiver is via the antenna terminals. When this condition has been attained, it is possible to connect a quartz-plate resonator between the antenna terminal and the antenna and thus assure that high field strengths from the near-by transmitters operating on adjacent channels will not reach the grid of the first tube in the receiver to cause cross modulation.

Other receiver characteristics are the same as those described for the aircraft receiver. The problem of an effective carrier-controlled output suppressor has been met in one design by the use of a separate intermediate-frequency channel employing a quartz-plate filter for the purpose of eliminating static side bands. The output of this channel serves to control the audio stages associated with the normal intermediate-frequency amplifier and second detector, so that the receiver output terminals have no voltage until a carrier is received. The crystal filter serves to render the control free from operation by static.

Ground-station Antennas.—There has probably been less development and improvement in ground-station antennas than in any other link in the aircraft-to-ground-station com-

munication chain. This is not because the matter has not been considered but because of the practical limitations attending the erection of such structures. A highly efficient ground-station antenna has as its attendant characteristics height, area, and directivity. On the other hand, most aeronautical transmitters are located at or near airports, thereby making antennas with heights of over 35 ft. very undesirable. Although receivers associated with major terminals are located away from the immediate vicinity of airports where height limitations may not exist, these are invariably located on private homesites where the available area is limited. Whether the antennas are to transmit or receive, they must do so to or from mobile stations capable of changing their locations. In case an airplane has left its true course, it must still be possible to communicate with it, and the high directivity of an antenna must not interfere with this function.

In view of these difficulties the antenna installations at ground stations have been erected consistent only with minimum standards. A common transmitting antenna is a half-wave wire energized with a single transmission line. This wire is generally installed at an angle of about 45 deg. on the theory that both vertically and horizontally polarized components were necessary for transmissions at all distances. A separate wire of this type is used for each transmitter frequency. For receiving, a doublet connecting to the receiver by means of a twisted pair from its center is commonly used. This antenna is often a half-wave long but in many cases serves for two frequencies, and the half wave-length relation is not observed at both frequencies. There have been some installations of vertical masts as transmitting antennas. Some of these have a small amount of top loading. At least one receiving antenna was designed which utilized some networks in its structure to improve the efficiency of the antenna at certain predetermined but widely separated frequencies.

As the aeronautical industry grows, the demand for long-range communication will increase. This increase can be met with additional frequencies in higher spectra, but these tend to "skip" at close distances, and it is desirable that the communication system cover the entire distance of the airline. This can be done with increased power on the ground in order to make for stronger signals at the airplane, but the maximum power of

the aircraft transmitter is, and probably always will be, subject to certain definite limitations. The only remaining solution is the directional ground-station receiving antenna which is capable of increasing the signal-to-noise ratio and thereby effectively increasing the power of the aircraft transmitter. Another totally different condition pointing to the eventual adoption of directional ground-station receiving antennas is the "quiet" remote receiver location previously mentioned. It often happens that after such a location has been found the city grows, bringing with it either its factories with their noise-generating equipment or residences with their equally noisy vacuum cleaners, electric razors, and dozens of other noise-generating home appliances. When this happens, the receiver location is moved farther away from the airport; then the process is repeated. At each move, the monthly cost of the telephone line between receiver and airport increases. The cost of locating quiet receiver sites alone amounts to a fair sum since on the average they are moved every 5 years, and the increased cost of telephone lines may soon justify the renting of adequate ground for directional antennas. The problem of directivity in relation to mobile stations can be answered by arranging a nondirectional antenna for emergency use with the thought that when this antenna is used reception would be as good as if a nondirectional antenna were present at all times. With this in mind, the characteristics of a directional antenna suitable for aeronautical ground-receiving station use will be discussed.

When a directional antenna is to be used for reception, the most important factor is not its gain in the desired direction but rather its signal-to-noise ratio(15). This means that it should receive from only one direction (direction in this case defined by three dimensions) and have no response from signals coming from any other direction. That is, the most efficient receiving antenna would be one having a very narrow unidirectional pencil as its space characteristic. The first factor that must be known when considering the design of a directional antenna, then, is the direction of arrival of the radio wave. From the previous discussion it seems apparent that waves will arrive directly from the airplane when the distance is 40 miles or less and from the ionosphere for distances ranging from 40 to 1,000 miles. When the waves are coming directly from the airplane,

it might be flying overhead; hence, the maximum angle from which reception is necessary (measured from the surface of the earth) will be 90 deg. By assuming transmission from the *E* layer at distances of 1,000 miles, a simple calculation shows that the minimum vertical angle of reception will necessarily be about 7 deg. This means that practically no directivity can be tolerated in the vertical plane. The only directivity that can be tolerated is a reduction in absolute gain at angles above 70 deg. because of the increased field strength of the direct signal. The only improvement that can be expected is from directivity in the horizontal plane. This directivity is governed by the normal path deviations that an airplane executes in the course of its routine flights. This angle can be plus or minus 15 deg.

Economics must also be considered in antenna design. From the previous discussion, it is obvious that the receiver must be capable of reception on a minimum of two frequencies. The coming of the longer range communications will demand operation on a minimum of three frequencies. Often when the antenna is located at a major terminal (and these antennas will probably be used only at terminals of this description), it is necessary that reception be had from two directions simultaneously. In order that this can be accomplished with only one structure, it is necessary that the antenna be directional in one direction at one frequency and directional in another direction at other frequencies.

There are numerous kinds of directional antennas that can be considered. Generally speaking, they can be classed as curtain(16) type, vertical(17) radiator type, or rhombic(15) type. The curtain type consists of wires arranged both vertically and horizontally on a suitable structure. An example of this type of antenna is the Sterba curtain. The length of each wire in this antenna bears a definite relation to the wave length for which the system is designed. This means that at least three such structures would have to be constructed. Economically then, this type of antenna would be undesirable.

Single-frequency operation is also a characteristic of directive arrays employing vertical elements; however, it is not necessary that the elements be a fixed length, and it may be possible to provide suitable tuning units that will be satisfactory on the

desired frequencies. Supporting structures must be supplied; hence the cost will not be low. A typical directivity pattern in the vertical plane for a quarter-wave antenna is shown in Fig. 179. An examination of this pattern shows that it is

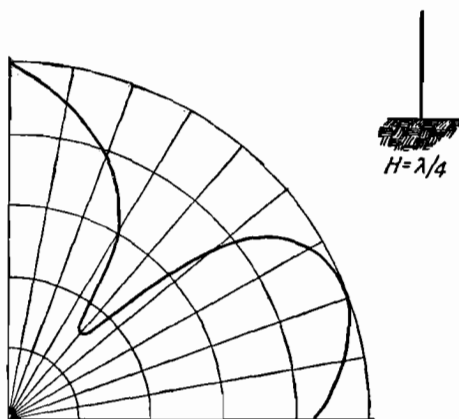

FIG. 179.—Field pattern of a quarter-wave vertical antenna in the vertical plane.

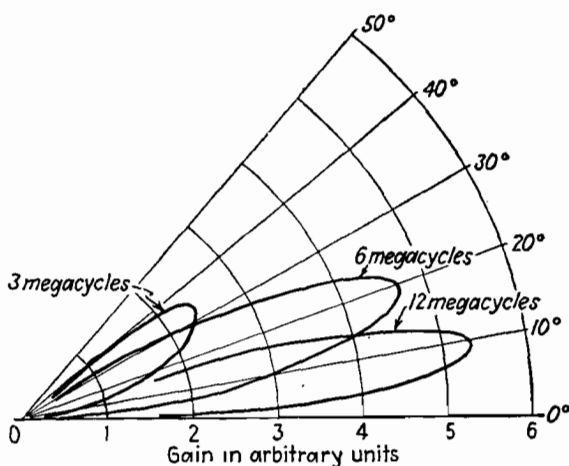

FIG. 180.—Vertical-plane field pattern of a rhombic antenna at three frequencies.

consistent with the directional specification previously discussed; hence, the vertical antenna is a possible solution to the problem.

By far the most inexpensive structure is the rhombic antenna consisting of four poles holding two wires to form a diamond pattern in the horizontal plane. By properly terminating the

rhombic with receivers at both ends, the antenna can be made unidirectional in two separate directions and at two different sets of frequencies. It is capable of giving satisfactory operation over a range of frequencies as great as 3 to 1. This antenna has a particularly great front-to-back ratio and, hence, is especially suitable for receiver work. An examination of its vertical plane directivity shown in Fig. 180 indicates that it is not capable of reception at angles higher than approximately 20 deg. This type of antenna can be used for reception of aeronautical mobile signals, then, only when it is combined with another antenna giving close-in reception.

From this discussion it can be concluded that directional antennas for aeronautical ground-station use are not an insurmountable problem, but more than usual considerations must be employed in order to obtain a successful design.

Problems

1. Plot the field strength delivered on the ground by an aircraft transmitter at an elevation of 11,000 ft. (aboveground). Assume that the terrain is fertile land and the transmitting frequency is 8 megacycles. The field strength measured $\frac{1}{2}$ mile from the station is 30,000 μv per meter.

2. What field strength will be delivered at 1 mile by a transmitter the output tube of which will deliver 100 watts into an impedance of 3,000 ohms? The output coil has a Q of 200; the transmitter frequency is 6 megacycles; and the transmitter connects to the antenna, the characteristics of which are shown in Fig. 171. The efficiency of this antenna is assumed to be half that of a quarter-wave antenna.

3. Assuming the ionosphere characteristics shown in Figs. 163 and 164, a choice of either 8 or 12 megacycles is offered to a communications engineer who wishes to communicate at a distance of 1,000 miles. Which should he choose? Describe the performance with time of day expected from the frequency of your choice.

4. What is the shortest distance that communications via the ionosphere will exist if the frequency is 5,700 kc. and the ionosphere conditions shown in Figs. 163 and 164 prevail?

5. Compute the characteristics of an antenna similar to that shown in Fig. 169 at frequencies between 3 and 6 megacycles. This antenna has a length of 30 ft. and is attached to a 4-ft. vertical fin. The length of the lead-in is 2 ft. and has a capacity of 20 μmf .

6. In order to obtain the desired power output, it is necessary to use two similar tubes in the output stage of an aircraft transmitter. Would you use these in parallel or push-pull? State fully the reasons for your choice.

7. What circuits can you suggest for a carrier-controlled output suppresser, the operation of which will be independent of static?

8. Develop Eqs. (207) and (208).

Bibliography

- 1 BURROWS, CHARLES R., and MARION C. GRAY: The Effect of the Earth's Curvature on Ground-wave Propagation, *Proc. I.R.E.*, Vol. 29, p. 16, January, 1941.
- 2 EVERITT, W. L.: "Communication Engineering," p. 514, McGraw-Hill Book Company, Inc., New York, 1932.
- 3 RIVES, TOM C., and JAMES C. COE: Characteristics of Electromagnetic Radiation from Aircraft in Flight, *Trans. A.I.E.E.*, Vol. 51, pp. 981-986, December, 1932.
- 4 KIRBY, S. S., L. V. BERKNER, and D. M. STUART: Studies of the Ionosphere and Their Application to Radio Transmission, *Proc. I.R.E.*, April, 1934, p. 481.
- 5 GILLILAND, THEODORE R.: Multifrequency Ionosphere Recording and Its Significance, *Proc. I.R.E.*, Vol. 23, p. 1076, September, 1935.
- 6 National Bureau of Standards: High-frequency Radio Transmission Conditions for July, 1941, *Proc. I.R.E.*, Vol. 29, p. 467, August, 1941.
- 7 SMITH, NEWBURN: Application of Vertical Incidence Ionosphere Measurements to Oblique Incidence Radio Transmission, *Nat. Bur. Standards Research Paper 1100*, Vol. 20, p. 683, May, 1938.
- 8 Radio Instruments and Measurements, *Bur. Standards Circ. 74*, p. 237, March, 1924.
- 9 Radio Instruments and Measurements, *Bur. Standards Circ. 74*, p. 243, March, 1924.
- 10 MORRISON, J. F., and P. H. SMITH: The Shunt Excited Antenna, *Proc. I.R.E.*, June, 1937, p. 695.
- 11 PIERCE, GEORGE W.: "Electric Oscillations and Electric Waves," p. 479, McGraw-Hill Book Company, Inc., New York, 1920.
- 12 SIEGEL, E., and J. LABUS: "Impedance of Antennas," *Hochfrequenztechnik und Elektroakustik*, Vol. 43, pp. 166-172, May, 1934.
- 13 HALLER, G. L.: Aircraft Antennas, paper presented before the I.R.E. National Convention, 1940.
- 14 SANDRETTO, P. C.: Some Principles in Aeronautical Ground-radio Station Design, *Proc. I.R.E.*, January, 1939, p. 5.
- 15 BRUCE, E.: Developments in Directive Short-wave Antennas, *Proc. I.R.E.*, Vol. 19, p. 1413, August, 1931.
- 16 STERBA, E. J.: Theoretical and Practical Aspects of Directional Transmitting Systems, *Proc. I.R.E.*, July, 1931, p. 1184.
- 17 SOUTHWORTH, G. C.: Certain Factors Affecting the Gain of Directive Antennas, *Proc. I.R.E.*, September, 1930, p. 1502.

CHAPTER X

ULTRA-HIGH-FREQUENCY COMMUNICATION

In the previous chapter an apparently satisfactory communication system operating at medium-high frequencies was discussed, so the question naturally arises as to the reason for a communication system utilizing ultra-high frequencies. The reason lies in two weaknesses of the medium-high frequencies. These are (1) the scarcity of these frequencies, and (2) their susceptibility to static.

To elaborate on the first characteristic mentioned above, the increase in the number of airplanes in one sector of an airway has greatly increased the number of contacts that must be made on the frequency used in that sector. When this occurs, an attempt is made to secure a second frequency; however, the frequencies that were available have all been allocated, and so it is necessary to turn to the ultra-high-frequency spectrum in order to secure the desired channels. The use of ultra-high frequencies as a substitute for the medium-high frequencies has been questioned because of their widely different propagation characteristics. It is true that the propagation characteristics of the ultra-high frequencies are such as to render them inapplicable in the manner in which the medium-high frequencies have been used, but a plan has been formulated which, if followed, indicates that the ultra-high frequencies will be as useful as those of the lower spectrum.

In the previous chapter communication over long distances was discussed, but from what has been said in Chap. III, it is apparent that the ultra-high frequencies can be used over short distances only; however, an analysis of the communications that are necessary for the proper operation of a commercial transport airplane shows that they are of the following types:

1. To the company dispatcher for giving and requesting information pertinent to method of procedure
2. To another airplane in the vicinity for the purpose of obtaining direct weather and positional information. Positional information is for the prevention of collisions

3. To the Airways Traffic Control group (via the company station) for permission to proceed to the airport from the airway

4. To the airport control tower for barometer readings and airport clearance

Of these four types of information interchange, three occur when the airplane is near the vicinity of the airport. One study made by an airline showed that of the total time that a frequency was utilized 60 per cent was for communication near the airport. If this is true, the ultra-high frequencies will indeed perform a huge task. Although it is very difficult to state that one type of communication is more important than another, the lower fuel supply carried by an airplane when it nears its destination and the dangers of collision prevalent at the larger air terminals make close-in communication of prime importance. Here the fact that ultra-high-frequency waves are but slightly susceptible to static would indicate that they can be expected to perform a good service, since their use should enable this vital information to reach the pilot regardless of the atmospheric conditions. There is another characteristic of these frequencies which also contributes to making them ideally suited for this particular service. Since all the information communicated when an airplane is close in is of interest chiefly to the airplane, the limited range of these frequencies allows their use at any number of terminals separated by a distance of only about 150 miles without interference, so the same frequency may be used simultaneously over many portions of the same airline.

It can be noticed that the preceding discussion has been made on a basis of what is to be rather than on a basis of what has been done. The reason for this is that ultra-high-frequency communication for the airlines is to be inaugurated in 1942. The work done thus far has been of an experimental or development character, and this chapter is more in the nature of a laboratory report than a history of an accomplished fact. The airlines of the country have conducted tests on the system for communications and believe that it will be practical. They have done developmental work on antennas and have set up specifications for equipment that is desired. Purchase orders have been issued for this equipment, but its delivery is now long overdue. The system set up contemplates the use of frequencies in a band

of 140 to 144 megacycles. It is intended that this system will provide a common channel to allow the airplanes of the various airlines to communicate with each other. Another purpose is to remove the airport control-tower communications from the medium-high and 278-kc. frequencies and place them on the ultra-high-frequency band. The company communications on ultra-high frequencies that are contemplated vary with the individual airlines. Some that have been hard pressed for additional frequencies intend to equip their ground stations fully with this ultra-high-frequency equipment, whereas others are making only partial installations while awaiting further service proving of the equipment.

Wave Polarization for Communications Use.—The type of polarization that has been chosen for communications use is vertical and is, therefore, in direct contrast with that for range use. One of the principal reasons for this choice is that it permits the use of a very simple antenna on the airplane. A further reason is that vertically polarized waves are somewhat less attenuated during propagation than are horizontally polarized waves. Whether or not this second factor will prove significant in actual practice remains to be seen.

Type of Modulation.—Modulation by varying the frequency(1) rather than the amplitude has recently been highly publicized and has been the subject of much discussion among radio engineers. The outstanding advantage claimed for this type of modulation is that it produces signals that are free from static, and it was necessary for the airlines to decide whether to employ this type of modulation or the more conventional amplitude type. Comparative tests were made with amplitude- and frequency-modulated equipments which were as nearly identical as possible. Although these tests showed some excellent performance for frequency-modulated equipment, they failed to show the advantages that had been claimed by experimenters using frequency-modulated equipment at 40 megacycles. It is believed that the higher carrier frequency employed in these tests, together with the lower ignition noise level on the modern well-shielded airplane, probably accounts for this result. Since it was very urgent that the ultra-high-frequency program be started, and since it was felt that the application of ultra-high frequencies to airline communication would alone introduce

many new problems, equipment of a type consistent with the better known art was chosen with the thought that it will be changed at a later time should frequency modulation prove, upon further tests, to have outstanding advantages. Amplitude

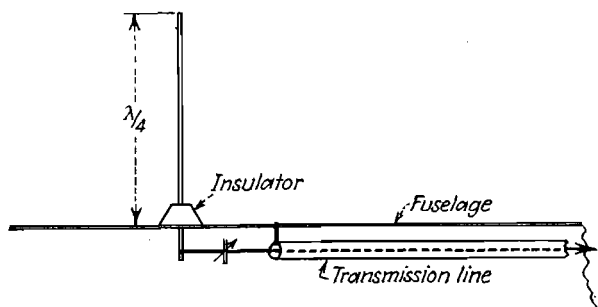

FIG. 181.—Series-fed vertically polarized ultra-high-frequency antenna for aircraft.

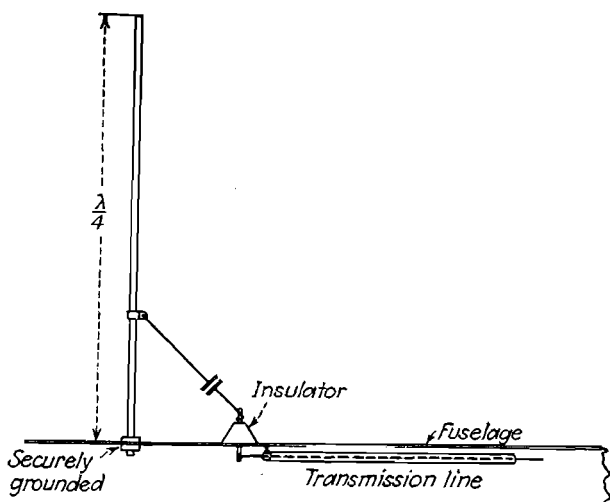

FIG. 182.—Shunt-excited vertically polarized ultra-high-frequency antenna for aircraft.

modulation is to be used, and, in the meantime, the improvements in the design of frequency-modulated equipment will take place.

Ultra-high-frequency Airplane Communications Antenna.—It has previously been mentioned that the employment of vertically

polarized waves permits the use of a simple antenna. The antenna devised is a small vertical rod with a height of about 20 in. This rod is made of stainless steel, has a base diameter of $\frac{1}{4}$ in., and tapers to a $\frac{1}{16}$ -in. section. It may be fed either in series or in shunt. If the antenna is fed in series, its base is insulated from the airplane and it is connected to the center



FIG. 183.—Various ultra-high-frequency communications antennas installed on airplane for tests. In the text the antenna immediately in front of the vertical fin is designated as No. 1, that behind the tail as No. 2, that located farthest forward as No. 3, and that mounted on the vertical fin as No. 4. (Courtesy United Air Lines.)

conductor of a coaxial transmission line (see Fig. 181). A variable series condenser is used for tuning. The shunt antenna has a length equal to that of the series antenna, but its base is grounded directly to the skin of the airplane. Coupling to it is made by a skew wire transmission line connected at a point about 6 in. from the base of the mast. A condenser having a capacity of about $15 \mu\text{mf}$ is used to couple the open-wire trans-

mission line to the coaxial line. The coaxial line is brought to the outside of the airplane by means of an insulator, and the necessary small condenser is formed by a sleeve over the end of the insulator lead-in screw (see Fig. 182). The shunt-fed antenna(2) has the advantage in that it separates the electrical problem from the mechanical problem involved in supporting the mast. Masts of this type have at times been broken when their

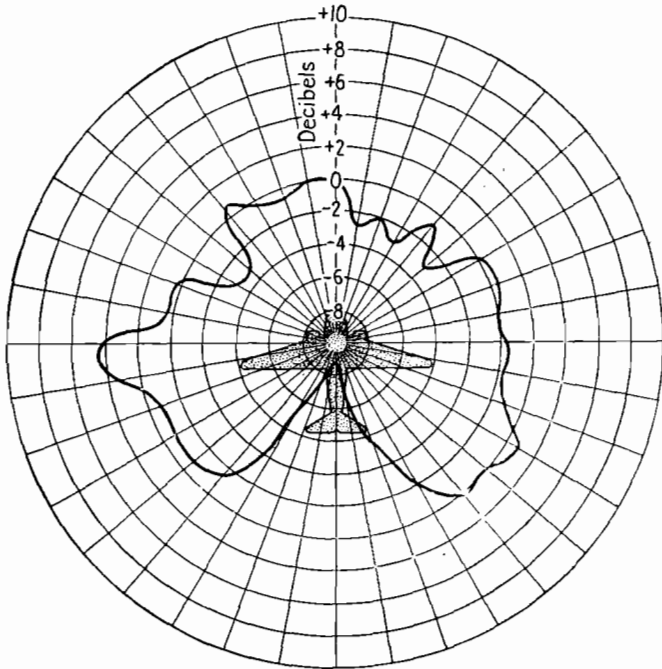

FIG. 184.—Horizontal-plane field pattern of the No. 1 antenna of Fig. 183.

mechanical resonance periods happen to fall near one of the frequencies generated by the propeller.

The length of 20 in. is one-quarter wave length. Longer lengths have been tried without noticeable improvement in field strengths.

The tuning of these antennas must be accomplished with a field-strength indicator. A vacuum-tube voltmeter equipped with a vertical antenna suitably tuned to the carrier frequency is placed near the airplane. The antenna is adjusted until the meter reading is maximum. The stray capacities involved in

directly attached current-indicating devices have made them unsuitable as a means for making adjustments. After the antenna is once adjusted, a resonance indicator at the transmitter is satisfactory for accomplishing further apparatus tuning.

Antenna Space Patterns.—Although the antenna has a simple structure, the determination of its best location on the aircraft

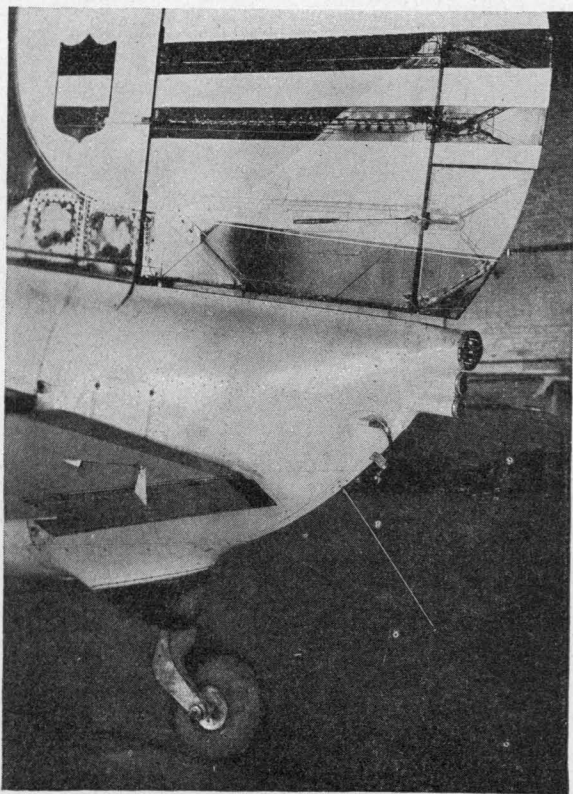

FIG. 185.—Antenna mounted behind tail wheel and below fuselage in order to minimize the effect of the fin shadow. In the text this antenna is referred to as No. 2.

was a problem that required extensive investigation. It was found in the early experiments with ultra-high-frequency waves that the propellers tended to modulate the transmission and reception. This modulation was very complete and took place at a frequency that was the product of the speed of the propellers and the number of blades on them. It was impossible to under-

stand signals so modulated. The discovery of this phenomenon was the source of considerable alarm because of the thought that it might preclude the use of ultra-high frequencies on aircraft. Later investigations, however, showed that this was purely an effect that existed between propeller and antenna, and if the antenna was removed sufficiently from the propeller, this effect was minimized.

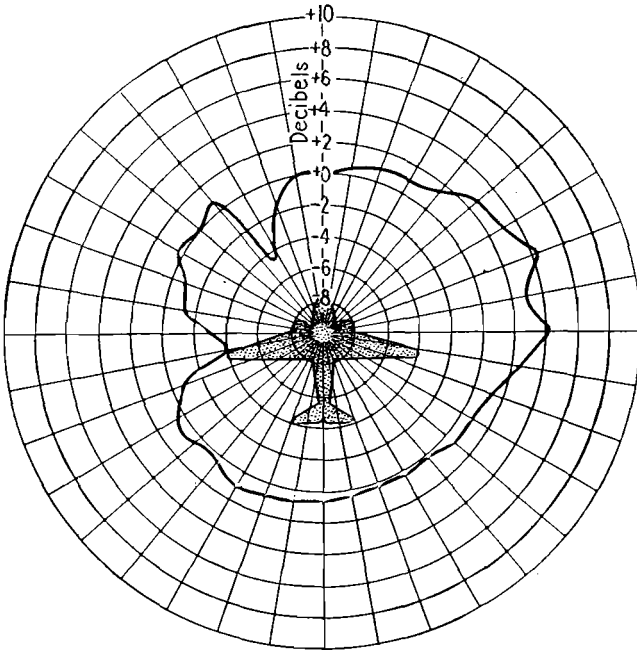

FIG. 186.—Horizontal-plane field pattern of the antenna shown on Fig. 185.

One of the possible locations is shown at number (1) in Fig. 183. This antenna is located on top of the fuselage and at an arbitrary distance from the vertical fin. By flying in a circle with an airplane equipped with this antenna, the field-strength pattern shown in Fig. 184 was obtained by using recording devices. It can be seen from this figure that signal is not transmitted in the direction toward the rear of the airplane's vertical fin. Clearly, this is a "shadow" effect caused by this vertical member.

Another similar antenna was located below the fuselage and to the rear of the tail wheel, as shown in Fig. 185. The

thought was that this location would eliminate the vertical-fin shadow. As shown in Fig. 186, this shadow is eliminated; however, when the airplane is banked, the effects of the wings can be noticed.

Since the fuselage might give a shadow above the airplane, the antenna behind the tail wheel was connected in parallel with the antenna over the fuselage, without attempting to secure

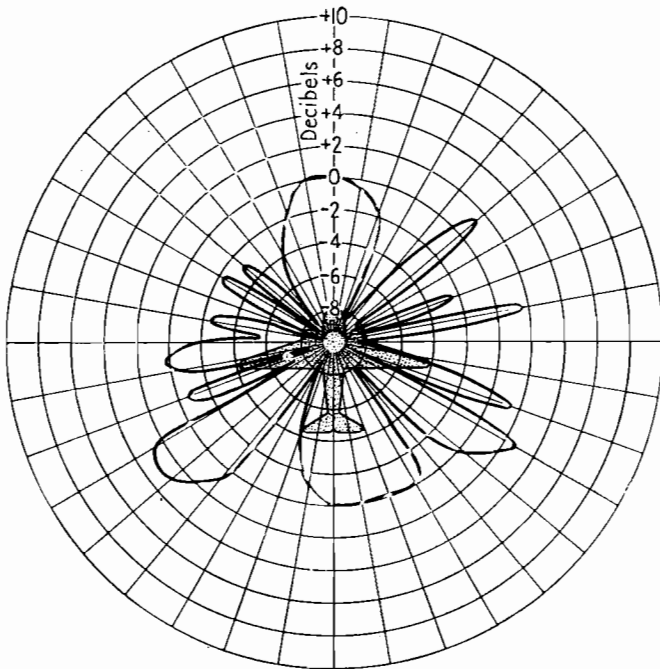

FIG. 187.—Horizontal-plane field pattern resulting from the combination of the No. 1 and No. 2 antennas.

optimum phasing. The results are shown in Fig. 187. This pattern is not satisfactory because it produced a large number of areas in which no signals were present, or rather where the signal strength was very low.

Another antenna location is shown by number (4) in Fig. 183. This antenna is located on the highest point on the airplane, that is, on top of the vertical fin. This location has the disadvantage that it requires a longer transmission line than do other antennas it is difficult to service, and it may interfere with certain hangar

structures. As shown in Fig. 188, however, its field pattern is quite good. The slight lobes shown are probably caused by the banked attitude of the airplane.

The field-strength pattern shown in Fig. 189 is for an antenna located over the fuselage. It is in front of the vertical fin of the airplane as was the number (1) antenna; however, Fig. 189 does not show any sharp nulls to be

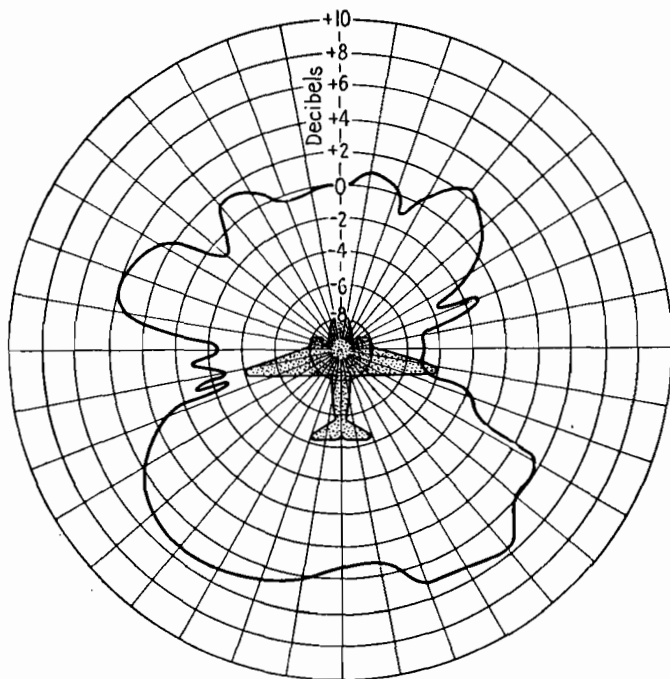

FIG. 188.—Horizontal-plane field pattern of the antenna mounted on the vertical fin.

present. The location for this antenna was determined experimentally. A vacuum-tube voltmeter was placed directly in back of the airplane's vertical fin, and the antenna was moved along until a point was found where the signal to the rear was maximum. This location was found to be quite critical. Moving the antenna as little as 3 in. greatly changed the results. The exact mechanism that is operating to cause this transmission has not yet been analyzed; however, it must be that the various

surfaces on the airplane are acting to cause reflection to its rear. On a larger airplane two such spots were located. Both of these were to the rear of the airplane where propeller modulation was not a factor.

Other Transmission Anomalies.—The field strength produced at a ground receiving station by an airplane carrying the vertical antenna located at the optimum distance in front of the vertical

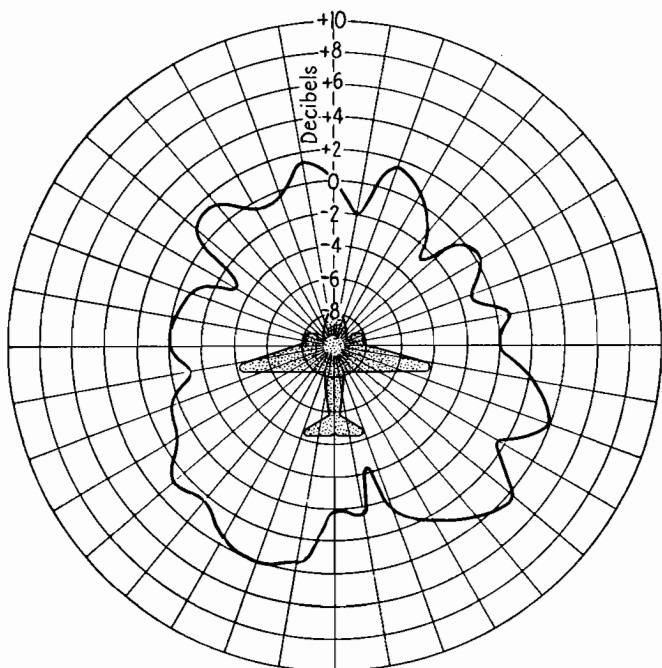

FIG. 189.—Horizontal-plane field pattern of the antenna mounted on top of the fuselage and at a distance in front of the vertical fin which makes the radiation to the rear of the airplane maximum.

fin, as the airplane flew toward, over, and away from the station, is shown in Figs. 190 and 191. The data on the curve of Fig. 190 are taken with the airplane at an altitude of 1,000 ft.; the data of Fig. 191 were taken with the airplane at an altitude of 4,500 ft. Referring to Fig. 191, a number of dips in the field-strength curve may be seen. Although the relation between the data of Figs. 190 and 191 is not absolute, it can be seen that the ratio between the maximum and minimum field strength is not so

great for the lower altitude flight as for the flight at the higher altitude. That is, it was found that signals could be heard at greater distance with the airplane at the higher altitude, but irregularities in the transmitted field strength occurred at the higher altitude that were not present with the airplane at the lower levels. A simple explanation for the deep dip shown at the 13-mile point in Fig. 191 may be explained by referring to Fig. 192. With the effective height of the aircraft transmitting antenna assumed as two thirds of the actual height, the angle of

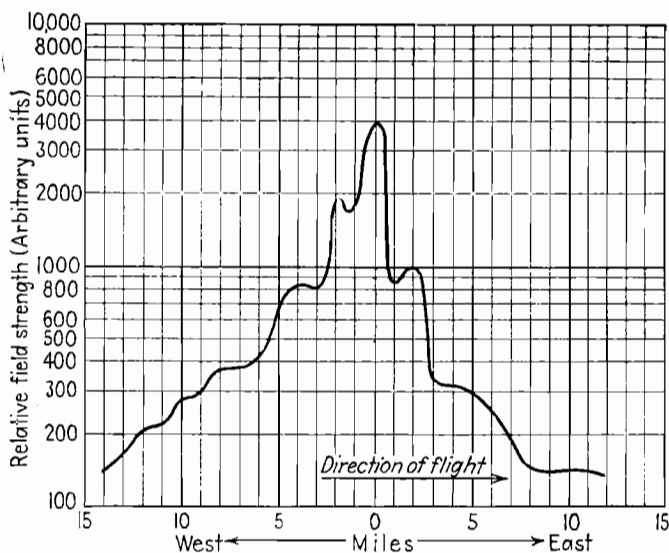

FIG. 190.—Variation of field strength with distance of airplane from receiver. Airplane altitude is 1,000 ft.

transmission (from the antenna to the ground) which just grazed the surface of the airplane was calculated to be 3 deg., 15 min. (measured between a horizontal line and the transmission path). At a distance of 9.8 miles the line of transmission to the airplane from the ground makes a zenithal angle of 3 deg., 40 min. with the airplane at an altitude of 4,500 ft. These simple calculations, then, suggest that the low signal valley is caused by a shadow from the fuselage of the airplane. This theory would indicate that beyond this point the field strength should remain low or perhaps even disappear. This, however, is not the case. Referring to Fig. 191, it can be seen that the field strength gradually

increases. This increase is explained by assuming that the signal heard with the airplane closer to the station than 9.8 miles comes to the ground station via refraction around the shadow cast

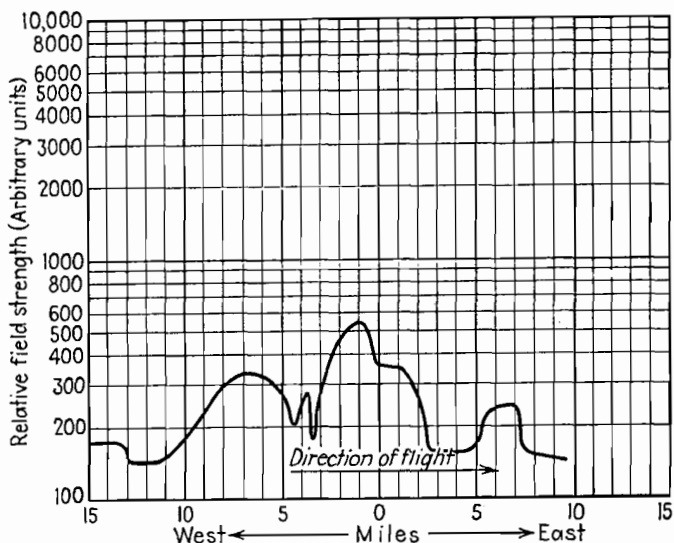

FIG. 191.—Variation of field strength with distance of airplane from transmitter. Altitude of airplane is 5,000 ft.

by the airplane structure. Calculations with other types of antennas have shown this same dip at similarly calculated grazing angles. No data are available, however, on transmission from other types of airplanes. Not shown on these figures, but found

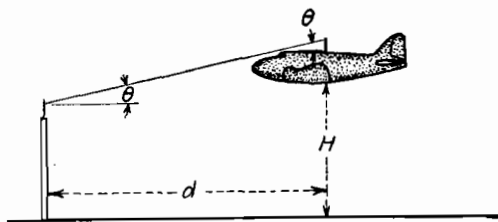

FIG. 192.—Illustration of the shadow angle caused by the fuselage of the airplane when at certain critical distances from the receiving station.

in other tests, are variations in signal strengths with close-in distances. These variations cannot be explained on the basis of the classical theory that they represent interferences between

the direct wave and the ground-reflected wave, assuming ground to be a plane surface. It has been found, however, that these variations are much more prevalent when the airplane is flying over heavily, rather than thinly, populated territory. It is believed, then, that these variations in intensity are caused by interferences between the direct wave and a wave reflected from the various buildings in the heavily populated areas. These phenomena may, in the future, influence the development of ultra-high-frequency communications systems.

The Airplane Transmitter.—The transmitter that has been specified by the airlines, and the delivery of which they are anxiously awaiting, is contained in the same case with the receiver. It is to operate on four frequencies in the range from 140 to 144 megacycles and deliver between 5 and 10 watts of power at any three frequencies with a total separation not to exceed 1 megacycle. The frequency to be used for interairplane communication is 140.1 megacycles, and if the three previously mentioned frequencies lie close to the 144-megacycle end of the spectrum, it is necessary only to deliver 1 watt of power at the interairplane frequency.

Since the transmitter, receiver, and power supply are contained in a one-ATR unit chassis (see Appendix), the foregoing provisions of the specification are quite stringent, and an elaborate frequency-changing mechanism is not possible. Frequencies are changed by the simple expedient of changing the oscillator crystals. A relay is connected to each of four crystals, and these relays close to select one crystal of the four, and hence the desired frequency results. The oscillator is not common to both the transmitter and receiver but serves for the transmitter alone. The oscillator is followed by three harmonic generators (in order that the crystal frequency may be multiplied to the proper value) then by a power output stage. The second harmonic of the oscillator is used to excite a frequency tripling stage. This stage excites another tripling stage which in turn excites a doubling stage, making the total frequency multiplication 36. This multiplication allows the use of crystals ground to a fundamental frequency of about 4 megacycles. Crystals of this frequency are easily produced.

The output stage consists of one of the high-frequency tubes that have become available in recent years. This tube consists

of two screen-grid tetrodes in a single glass envelope. The two tetrodes when used together have a plate dissipation rating of 50 watts. These two sets of tube elements are operated in push-pull, since parallel operation would introduce capacities that were too high. A coupling circuit adapts the output for operation against ground. The output connection is intended to be a 72-ohm coaxial transmission line. There is hardly room for the higher efficiency transmission lines to be used as tuning elements, so all circuits follow the more conventional condenser and coil arrangement. Again because of the space problem, no variable condensers are used. The comparatively narrow frequency band width simplifies this tuning problem. The earlier stages utilize powdered iron slugs as tuning elements, and the later stages use copper or brass slugs. Some of the coils used in the harmonic amplifiers consist merely of $\frac{1}{4}$ in. diameter Bakelite dowels wound with a few turns of bare wire. A brass screw threaded through their centers serves as the tuning arrangement.

Other requirements for this transmitter are rather conventional. The last stage is modulated 100 per cent with a pair of class B audio tubes. A carbon microphone through a suitable transformer operates the class B tubes directly. The audio response of the transmitter is specified as flat from 400 to 3,000 cycles, with the response to lower frequencies reduced so that it is at least 12 db below the normal level at 1,000 cycles. The distortion with 95 per cent modulation is not more than 10 per cent.

The Airplane Receiver.—Since it is intended that interairplane communication be used as a means for collision prevention, this receiver is designed so that reception of the 140.1-megacycle channel is given special consideration. The receiver is, of course, of the superheterodyne type, but it has two radio-frequency sections connecting in parallel between the antenna and the intermediate-frequency amplifying system. Although the frequencies of the receiver are selected at the same time that the transmitter frequencies are chosen, the 140.1-megacycle receiving channel remains in operation at all times. That is, if the frequency of 140.1 megacycles is chosen, both the receiver and the transmitter will operate on this frequency alone, but if any other frequency is selected, the transmitter and receiver will oper-

ate on this new frequency, and, in addition, reception of the 140.1-megacycle channel will continue. This facility, then, will allow a pilot to call a near-by airplane with assurance that he will be heard regardless of which channel the called airplane has selected. In this manner it is expected that a warning may be sounded and heard at any time.

The receiver is to have a sensitivity of $5\mu\text{v}$ with a signal-to-noise ratio of 10 db (measured with a 30 per cent modulated carrier). The selectivity is specified as a band width of not more than 300 kc. with an attenuation of not less than 60 db. An image-frequency attenuation and an attenuation to all other responses of at least 40 db are specified.

Although double demodulation is often used in ultra-high-frequency receivers, such design would complicate this already complex equipment; so, since it has been found possible to obtain the specified performance with the more conventional design using a single demodulator, better performance has not been attempted. The increased use of these ultra-high frequencies may make an increase in selectivity necessary at a later date, in which case this equipment will have to be replaced.

Following the crystal oscillator there are three harmonic generators. One section of a double triode tube is used for the oscillator and the other for a harmonic generator. Both sections of a second double triode are also used for harmonic generators, so the entire beating-frequency generator system consists only of two tubes. The fact that there are no screens in these tubes is no cause for regeneration because the input and output circuits of each tube are tuned to a different frequency. The first tubes connecting to the antenna are the first detectors. There are two first detectors—one of which is for the 140.1-megacycle stage and the other for the remaining three frequencies. The output circuits of these tubes are connected together. The input of each tube is connected to a separate antenna network for image-frequency rejection. These networks have been described in Chap. III. All tuning methods used in the harmonic generators and antenna circuits are of the type previously described for the transmitter.

The image frequency employed is 10,000 kc. Since virtually all the receiver selectivity must be attained in the intermediate-amplification stages, three such stages are employed.

One of the other characteristics specified for this receiver is an automatic gain control which holds the gain constant to within 6 db, with variation in antenna input of 10 to 100,000 μ v. It is also specified that the receiver shall not block with input signals having a strength of as much as 2 volts. Since the gain of the coupling systems before the first detectors is negligible, this latter requirement can be met without the addition of special limiting devices.

The audio system is specified as flat to within 3 db. from 250 to 2,500 cycles. Two audio stages, each with an output of 500 mw., are used. A noise limiter and a simple carrier-controlled output disabling circuit have been included. This carrier-controlled device disables the audio system until a carrier wave is received.

As previously mentioned, the power supply for the receiver and transmitter is contained in the same chassis with the receiver and the same dynamotor is used for both. The weight of this equipment in complete operating condition is 37 lb. A meter is supplied which, together with a suitable selector switch, allows tuning adjustments to be made without external measuring apparatus.

The Ground-station Transmitter.—The transmitter for ground station use has a greater frequency range than that of the aircraft unit. Its range is specified from 128 to 144 megacycles. It is to operate on any three frequencies in this range provided that the separation is not more than 1 megacycle between each frequency. The power output has been chosen as 50 watts. This figure was chosen more because it was a convenient value of power that could be generated by modern tube types rather than because exhaustive tests have shown it to be optimum. Adjustment of this power figure may have to be made after the equipment is in service for some time. Because of the simplified frequency-channel requirement, it is possible to use the same method of frequency shifting that was employed in the transmitter; that is, merely changing oscillator quartz crystals. The use of modern quartz crystals allows a frequency stability of plus or minus 0.01 per cent under changing conditions of temperature, humidity, or line voltage.

This transmitter is to be designed for relay-rack mounting and for continuous-duty operation. The conditions of tempera-

ture to be met are from minus 10 to plus 50°C. and from 5 to 95 per cent relative humidity. It is operated from a self-contained power supply connecting to a single-phase power line. The transmitter is expected to operate properly when the voltage of this line varies from 105 to 125.

It is specified that parasitic and other spurious oscillations shall not be present.

Other transmitter performance is specified to be similar to that previously described for the aircraft transmitter.

The Ground-station Receiver.—The characteristics specified for the ground-station receiver are essentially the same as those specified for the aircraft unit. The chief difference between the two units lies in their mechanical construction. The ground-station unit is to be relay-rack mounted and so constructed that it may be easily serviced from the front of the relay rack. It is to operate from alternating current (single-phase supply) and meet the operating conditions specified above for the ground-station transmitter. It has the same frequency range as the transmitter (128 to 144 megacycles) but is intended to operate only on a single frequency. In order to permit operation on more than one frequency, it is intended that more than one receiver shall be used, so it has been specified that three receivers shall connect to the same antenna without interaction. This requirement will necessitate special design in order that the beating-oscillator frequency in one receiver will not cause a disturbance in another receiver. This will probably necessitate the use of radio-frequency stages before the first detector. This is a feature of design that was not incorporated in the aircraft receiver.

The noise limiter, automatic gain control, and carrier-controlled audio-disabling circuit are specified to be much the same as those for the aircraft receiver. The audio system is not dual, since this requirement is usually confined to aircraft equipment.

Ground-station Antennas.—There are two requirements for ground-station antennas. It is intended that the aircraft transmitter previously described shall communicate with the airport control towers probably on a frequency of 140.1 megacycles and the airport tower shall answer on a frequency of 130.4 megacycles. The reception of this tower frequency cannot be accomplished with the equipment just described, so it must be done

with the range equipment described in Chap. III. Since the range antenna is designed for the exclusive reception of horizontally polarized waves, the airport-tower transmitter must use an antenna that transmits essentially horizontally polarized waves (for example the Alford loop). The reception of the airplane signal must, however, be accomplished with a vertical antenna.

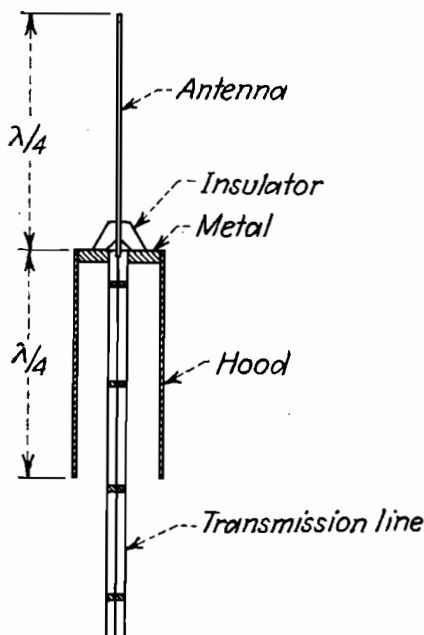

FIG. 193.—Western Electric-type ground-station antenna for ultra-high-frequency reception and transmission.

This same antenna will also be used for reception and transmission at the airline ground station. That is, although the airline station may use the same antenna for both transmission and reception, the airport station must use separate antennas. Whether it will be necessary to locate receivers remotely from the airport because of local noise conditions is not known. If it is necessary to do this, it may be possible to locate antennas at considerable heights aboveground. If receivers are located locally, the antenna height will be definitely limited because tall antennas constitute a hazard to landing airplanes. The ver-

tically polarized antenna that is well suited to this work, whether for reception or transmission, is one devised by the Bell Telephone Laboratories and shown on the diagram of Fig. 193. As can be seen from this figure, the antenna is designed to be connected to a coaxial transmission line. The line enters a large tubing but is not connected to it. It is supported in the center of this tubing with insulators and terminates in an insulator at the top of the tubing. At this point the inner conductor of the transmission line connects to a vertical rod of small diameter and one-quarter wave length in height. Also at this point the outer conductor connects to the large tubing through which it has previously passed. The length of this large tubing is one-quarter wave. The diameter of this larger tubing is usually 3 in., and apparently this dimension is not critical. The theory of this antenna is that the high impedance between the outer sheath and the coaxial cable existing because of the low impedance at the opposite end of the combination serves virtually to cut off electrically the transmission line and in so doing increases the efficiency. This antenna may be located at any desired height from the ground, but it follows, of course, that if this height is too great, the transmission line losses will offset the antenna gain. The efficiency of this antenna is high. The field strength produced by it at 1 mile has been measured to be very nearly 6.14 microvolts per meter per watt of input power, which is the theoretical figure for a 100 per cent efficient quarter-wave antenna.

Microwave Communication.—It has been mentioned that one of the purposes of the new communication system operating at ultra-high frequencies is the prevention of collision. In many respects the proposed system is like a radio-actuated klaxon. The pilot of one airplane can transmit a message over the 140.1-megacycle channel as a warning to any other airplane in the vicinity. This collision-warning system must be manually operated; therefore, it is not entirely satisfactory. The presence of the second airplane can be learned only if a transmission is heard from it. If it cannot be sighted, it is necessary to exchange positional information, and this process may take too much time. An automatic means would be the more satisfactory method.

It can be seen from the extensive program of communication for which the ultra-high-frequency channels are to be used that

the time may come when the capacity of these channels will be fully occupied. At this time it will be necessary to look to newer spectra, and this new band will consist of those waves having a frequency higher than 500 megacycles. Since the collision-warning system will require improvement, it is only logical to prophesy that this service will be moved to the microwave bands. Besides regular voice communication, a transmitter may be connected so that it is transmitting at all times. A receiver connected to a directional antenna arranged so that it continually scans all the near-by space will, like a three-dimensional automatic direction finder, serve to indicate the location of the near-by airplanes. Since an indicating system would give, instantaneously, the location of other near-by airplanes without the necessity for any manipulation of communication circuits by either pilot, it would be possible for them to concentrate on avoiding the other airplane.

The system described represents the discussions of communications men attempting to foretell the equipment that will fill the requirement of the nebulous future. The system that will actually be installed may not in any way resemble this plan, but whatever system is evolved, it is clear that the use of the ultra-high frequencies is destined to play an important part in aeronautical communication systems of the future.

Problems

1. Why does atmospheric static give less interference at 140 than at 40 megacycles? Explain fully.
2. Refer to technical literature, and write an explanation of the principles underlying the operation of the velocity-modulated tubes such as the Klystron. How will these devices affect the ultra-high-frequency communications program?

Bibliography

1. ARMSTRONG, EDWIN H.: A Method of Reducing Disturbances in Radio Signalling, *Proc. I.R.E.*, May, 1936, p. 689.
2. MORRISON, J. F., and P. H. SMITH: The Shunt Excited Antenna, *Proc. I.R.E.*, June, 1937, p. 695.

CHAPTER XI

AIRCRAFT POWER SUPPLY SYSTEMS

The systems for producing electrical energy aboard aircraft are linked inseparably with the radio apparatus used. These systems determine the power that is available and, hence, have a direct bearing on the number of radio units that it is practical to install. The instantaneous power that can be supplied

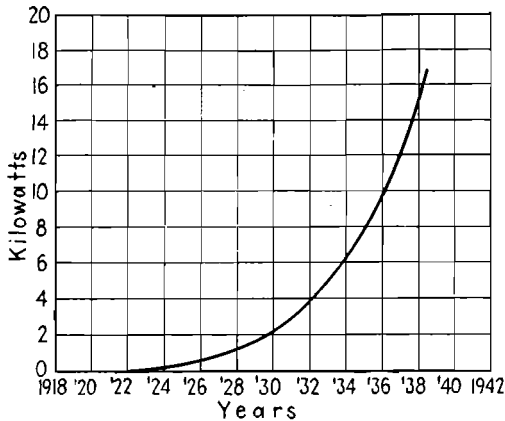

FIG. 194.—Increase in electrical power demand on commercial aircraft.

governs the design of the transmitters. The reliability of these supplies must be considered when the additional emergency radio units to be installed are determined. The interference generated in the radio apparatus by these systems must be considered when the radio installation is planned. Of course, the voltage supplied by them governs directly certain radio-set components such as vacuum-tube filaments, relays, and dynamotors.

Growth of Aircraft Electrical Demand.—During the first World War it was found difficult to obtain satisfactory magnetos, so the makers of certain airplane engines resorted to battery ignition systems. This marked the installation of the first battery power on aircraft. This battery had as its sole purpose

the operating of the airplane engine, but later, since a convenient source of electrical power was available, a few instrument lights were added. It is to be noted that although many sources of auxiliary power, such as hydraulic and pneumatic, can supply mechanical power, only the electrical power can supply effective light. The magneto was at a later time again placed on the airplane to supply ignition, but night flying had come into use, bringing with it the first landing lights; so the electrical system had attained a permanent place on the airplane and to it was connected the first radio. As the air-transport industry expanded and the complexity of the airplane grew, more and more items were added to the electrical system. The growth of the electrical demand is pictured in Fig. 194. It can be seen that between 1929 and 1938 the demand grew from 2 to 15 kw. This does not mean that the total connected load was 15 kw., but if all appliances on an aircraft were connected to the electrical system simultaneously, the drain would be 15 kw.

Electricity on a Modern Airplane.—There are several reasons for the growth of the electrical demand. • One of the most important of these is flight by instruments. The process of avigation between two points with the use of instruments alone has brought about a large demand for electricity by the many radio units discussed in other chapters. Aside from the radio demands, however, electricity is required for lights, pitot heaters, deicer valve motors, and instruments. In the large airplane the sensitive element of an instrument is placed at a distance from the cockpit and the indications are transmitted to the cockpit by means of miniature selsyn motors.

Nearly all the electrical loads required for avigating the airplane are relatively constant. That is, they are turned on at the beginning of a flight and are in nearly continuous use throughout the flight.

Another demand for electrical power comes from facilities for passengers. The electrical loads, in the main, consist of a large number of miscellaneous lights. Some of these are for the cabin ceiling, and others are for reading and for calling the cabin attendants. A certain amount of power is required for heating food. Electricity for heating water, as well as food, will be required in the larger airplanes of the future. These passenger-facility loads are more or less constant.

It has been stated that the first electrical power supply placed aboard an airplane was for the purpose of operating it. The demand for power for this purpose has also grown. In certain cases it was possible to meet this demand by hydraulic and pneumatic power, and certain designers have chosen these methods, thereby reducing the electrical demand. Electricity for operating the airplane consists of power for starting the engines, for certain warning lights, and for ignition booster coils.

Certain airplanes use electrical motors for retracting the landing gear. Many airplanes also feather the propellers by hydraulic pumps that are electrically driven. Plans for large airplanes include the use of electrically driven hydraulic and vacuum pumps. The simplicity of installing electrical wiring as compared with large hydraulic lines is a decided advantage when the added weight can be justified. All the loads used for operating the airplane are at present characterized by their very high momentary demands and short periods of operation.

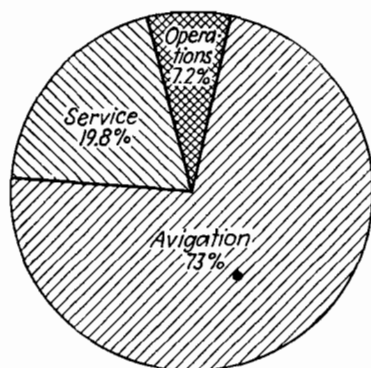

FIG. 195.—Classification of electrical power demand on a Douglas Model DC-3 airplane based on a 5-hr. flight.

Data showing the electrical demands on a modern airplane (the Douglas DC-3 Transport) are shown in Tables V, VI, and VII. These tables are the results of measurements made after the airplane was in service for a period of about 2 years and do not necessarily represent the loads that were present when the airplane was first in service nor the loads in use today. The power taken is expressed in ampere-minutes based on an estimated requirement for a 5-hr. flight made at night under instrument conditions. The percentage of the power used for each class of service is shown(1) in Fig. 195. It can be seen that the largest portion of the total power is consumed by avigational devices.

The Common Electrical System.—The power demanded by the first airplanes was low, so it was possible to supply it with a light 8-volt battery; however, when the demand for landing

lights arose, this voltage was increased in order to minimize the weight of the conductors necessary to carry the high current. All subsequent aircraft accessories were designed for 12 volts; therefore, it was natural for the industry to adhere to this 12-volt standard. The electrical demand of the modern type low-wing twin-engined airplane that made its appearance in 1932, and carried but three radio units, was met by the use of a single 65-amp.-hr. battery and a 50-amp. generator. The larger twin-motored airplane of 1936, carrying four radio units but destined to carry nine by 1942, had installed in it two of the systems used in the lighter airplanes. This step was the logical procedure since by so doing no new equipment had to be developed.

In this system the storage battery acts as a reservoir that can be used to meet the momentary large power demands. This statement may be illustrated by noticing that in Table V the starter requires 260 amp., or more than five times the capacity of the generator.

TABLE V.—OPERATION ELECTRICITY—DOUGLAS DC-3 AIRPLANE

Facility	Amp.	Amp.-min.
Warning lights.....	1.2	360
Landing-gear warning lights.....	0.7	210
Engine starters.....	260	520
Fuel and oil-pressure warning lights....	1.1	66
Booster coils.....	3	6
Total.....		1,162

Without considering how a generator with sufficient capacity would be driven, and assuming that such a requirement would be supplied by the generator, it would be necessary to install a unit weighing at least five times that of the usual generator. By installing a battery, this requirement is met with lower weight. True, the generators, after being installed, would continue to supply the 260 amp. for as long a period as the prime mover driving it continued to operate; whereas, the battery is capable of delivering this high power output for only a short period of time. This period is sufficient, however, to be consistent with the demands, for it can be seen in Table V that the starters are operated for only 2 min. The total drain listed in Tables V, VI,

and VII is 16,071 amp.-min., or an average of only 53.5 amp. per flight minute.

TABLE VI.—AVIGATION ELECTRICITY—DOUGLAS DC-3 AIRPLANE

Facility	Amp.	Amp.-min.
Windshield defroster fan.....	1.0	300
Argon dynamotor and/or instrument spotlight.....	1.5	450
Pitot heater.....	14.0	4,200
Running lights.....	2.5	750
Compass, gyro, and radio panel lights..	1.0	300
Instrument-panel lights.....	1.0	300
Radio-receiving dynamotor and receiver filament.....	7.3	2,190
Electrical instruments.....	1.0	300
Wing deicer.....	1.5	450
Transmitting dynamotor.....	60	900
Transmitting filaments.....	15	450
Landing lights.....	70	1,050
Baggage pits.....	2	90
278-kc. relay.....	0.4	2
Total.....	11,732

TABLE VII.—SERVICE ELECTRICITY—DOUGLAS DC-3 AIRPLANE

Facility	Amp.	Amp.-min.
Cabin side lights.....	6.2	1,960
Buffet lights.....	1.0	300
Cabin warning lights.....	2.5	100
Seat-belt warning.....	1.2	360
Companionway dome light.....	1.0	45
Stewardess call light.....	1.0	5
Cabin-light relay.....	0.5	30
Cabin dome lights.....	6.2	372
Entrance-door light.....	1.7	105
Total.....	...	3,177

This demand is easily met by the two 50-amp. generators and the two 65-amp.-hr. batteries, with sufficient spare capacity to allow for the radio loads later added, yet the sum of all the loads listed is 335 amp.

In order to meet the high demands it is necessary that the battery employed be of the lead-acid type. Naturally, batteries

of this type are heavy and, although efforts have been made to reduce the size of plates, 65-amp.-hr. batteries weigh 65 lb. This ampere-hour rating is based on a 5-hr. duty cycle. The tops of the plates of these batteries are located a considerable distance below the top of the battery cases in order to provide a nonspillable feature. Charging occurs during the time that the total current drawn is less than the generator capacity. The charging rate varies with the state of discharge of the battery. With a battery that has been heavily used, the rate may be as high as 50 amp. The charging voltage is generally set at approximately 14.2 volts.

The generators used are of the shunt type. By means of suitable gearing incorporated in the main engines, they operate at one and one-half times engine speed. They have a continuous rating of 50 amp. and can, at full engine speed, generate a voltage as high as 30. Each weighs 30 lb. The voltage is maintained at a constant value by a Tirrell-type regulator. This regulator consists, in the main, of a set of contacts that open and close with the pull of an electromagnet. This electromagnet is connected across the generator terminals and, hence, is sensitive to voltage variations. As the contacts open and close, they short- or open-circuit a resistor in series with the shunt field and, consequently, raise or lower the voltage. Since the generator voltage with the contacts closed would be too high and with the contacts open, too low, the correct voltage is maintained by the contacts vibrating rapidly between the closed and open positions. This voltage regulator is located in a box with two other generator controlling elements, and the entire unit is designated as a generator control box.

One of the other units is a regulator not unlike that described for voltage control except that the coil of the electromagnet is connected in series with the line and, hence, the operating relay is sensitive to the current drawn. This device, then, is a current regulator limiting the maximum amperage to be drawn from the generators to 50.

The third control-box element is an inverse current relay. When the generator voltage drops below that of the battery (caused, perhaps, by the engine speed being reduced to a low value), the battery would tend to discharge itself through the generator were it not for this relay. It allows current to flow

from the generator to the battery but not from the battery to the generator.

Generators were formerly connected to independent buses and arranged with switches so that either battery or either generator could be connected to either bus, but it has been demonstrated that successful parallel operation from this equipment can be obtained, and many of the systems have been converted to this type of operation.

Other Features of the Common Electrical System.—Common wiring practice makes use of tinned, stranded copper covered with two layers of varnished cambric and an over-all covering of varnished cotton braid. Stranded wire is used because experience has shown that it is better able to withstand vibration. Recently, wire insulated with fireproof covering has come into use. The insulation used is artificial rubber, asbestos, or spun glass, or a combination of several of these materials. Consideration has been given by various groups to the possible use of aluminum conductors in order to reduce weight. As is well known, the resistance of a length of wire L , with an area A , is given by(2)

$$r = \frac{\rho L}{A} \quad (209)$$

where ρ is the specific resistivity of the material from which the wire is made. The relative resistance of two conductors—one made of copper and the other of aluminum but both of the same length—is

$$\frac{r_c}{r_a} = \frac{\rho_c A_a}{\rho_a A_c} \quad (210)$$

The subscripts a and c refer to the constants of the aluminum and copper wires, respectively. If the resistance of the aluminum and the copper conductors is to be the same, then the relative areas of these conductors will be

$$A_a = 1.63A_c \quad (211)$$

since tables(3) show c to be 1.6 and a to be 2.6. That is, in order that an aluminum conductor may have the same resistance as a copper conductor, it must have 63 per cent more area than the copper conductor or approximately 28 per cent greater

circumference. However, since the weight of copper is 3.36 times that of aluminum, it would appear that aluminum conductors would be practical, but there are other considerations.

With an increase in the circumference of the conductor, the weight of insulation is increased by 28 per cent. Further, the diameter of the conduit in which this wire is installed increases 28 per cent, which means that if the wall thickness is not changed, the weight also increases in this same proportion. Thus, it is seen that the weight advantage of the aluminum conductor is not decisive. Considering the difficulty of attaching terminals to the ends of the aluminum conductors (it is difficult to solder aluminum), they have been used only for the very large cables.

In commercial transport airplanes all the wiring is installed in aluminum-alloy conduits. These conduits serve primarily as protection for the conductors, but they were originally installed with the thought that they would be significant in shielding radio equipment from noises generated by the electrical system. The conduits are terminated in various aluminum boxes. Some of these boxes contain terminal strips, some serve as connecting links joining rigid to flexible conduit which in turn connects to the apparatus units, and some are merely "pull" boxes installed to facilitate the drawing of wire into the conduits.

Fuses of the automotive type are used extensively. The most common sizes are the 4AG for currents less than 50 amp. and the 5AG for fuses that must carry larger currents. Failure of these fuses in considerable number has been experienced due to the crystallizing of the fuse links when subjected to vibration. Special fuse construction has been used to correct this situation. One of the methods employed consisted in adding a web to the link so that its rigidity was increased. Another method consisted in supporting the fusible links with strips of mica. Some thermal-type circuit breakers have recently been introduced. These have a diameter of about 1.25 in. and are about 1 in. deep. Tests thus far indicate that they are successful, but the extent to which they will replace the smaller and lighter fuse remains to be seen.

Small toggle switches are usually employed for controlling the electrical circuits. These switches are about 2 in. long, $\frac{3}{4}$ in. wide, and $1\frac{1}{2}$ in. deep. Currents in excess of 25 amp. are successfully carried by switches of this type. Relays are used

to advantage when currents in excess of this value are to be controlled.

The weakest point in the system described has been the generator control box. The vibrating elements used have not been successful. Some attempts have been made to design better units, but most of the equipment of this type has been designed for the new generators.

The generators have been satisfactory for the most part, and the only trouble that has been experienced with them has been brush wear. The newer generators are being designed with a field winding that is distributed along the face of the field poles. This winding is connected in series and serves as a very effective compound field. With this field, it no longer is necessary for the voltage regulator to take care of voltage variations caused by load changing since such variations have been reduced substantially to zero. It was possible, therefore, to design a slower operating regulator consisting of a voltage-sensitive element and a voltage-controlling element. The former is a small relay and the latter a rheostat controlled by a motor. There have been no extensive service tests of this equipment, but laboratory tests are very promising. For the present generators, regulators consisting of carbon piles compressed by the action of solenoids have just been introduced and have given satisfactory results under limited tests. Efforts to eliminate the current limiter are being made. No substitute is offered, but it is thought that, with sufficient capacity, short-circuit protection is all that is required for satisfactory operation. A substitute for the inverse-current relay has been tried in the form of a selenium rectifier. This rectifier, because it allows current to flow in only one direction, successfully accomplishes the same purpose for which the inverse-current relay is intended. This, however, is done only with a weight penalty.

Assuming complete discharge in 5 hr., the storage batteries on a DC-3 airplane would furnish 156 watts, but during this same period the generators would furnish 1,200 watts (approximately). The total power supplied is 1,356 watts. The weight for this supply is 190 lb., or the weight of this system is approximately 140 lb. per kilowatt.

The new generators have been designed to operate at higher speeds. An increase in gear ratio to 3 to 1 is contemplated.

This allows generators for developing 24 volts at 100 amp. to be designed, which will weigh 28 lb. It is intended that four of these generators, but only a single 65-amp.-hr., 24-volt battery, be carried on the larger airplanes. With this system the weight (on a 5-hr. discharge basis) will be about 19.8 lb. per kilowatt. This is a noteworthy decrease in weight.

Optimum Voltage for Aircraft.—The voltage of the present-day aircraft electrical systems was not selected because studies indicated that 12 was the best value, but rather because of a series of circumstances that attended the development of the aircraft. Considerable thought has been given to this subject in recent years, and a classical paper(4) on this subject has been published by Grant and Peters. Naturally, one of the prime requisites of the optimum voltage for an aircraft electrical system is that it produce the lowest possible weight. As is well known, the higher the voltage, the lower will be the weight of the wires employed in the distributing system up to the point where it is necessary to add insulation. With the insulation provided on a wire in order that it will be capable of withstanding the abrasion attending its installation, voltages as high as 500 could conceivably be used without exceeding the insulation limit. The lowest voltage that would provide minimum weight is that which would reduce the theoretical size of all conductors to No. 20 A.W.G. or smaller. This is because it has been found that mechanical considerations make impractical the installation of smaller wires, so when all wires need not be larger than No. 20, the wiring system has reached its lowest practical weight.

Studies of the weight of wiring systems can be made on a theoretical basis or by making actual calculations for a certain airplane. Grant and Peters determined formulas based on three assumptions, as follows:

1a. The weight of a conductor varies inversely as the square of the voltage, except for that portion given under 1c.

b. The weight of conduit and insulation varies inversely as the voltage.

c. A certain weight of cable and conduit is independent of voltage.

2a. The weight of conductor varies inversely as the square of the voltage.

b. The weight of conduit and insulation varies inversely as the voltage.

3. The weight of cable and conduit varies inversely as the square of the voltage.

By using the foregoing assumptions, several different formulas were derived. Each gave differing answers, but all the functions had the same shape, and all the answers were sufficiently close to serve as practical guides.

The results of a study for a large airplane (gross weight about 50,000 lb.) are shown in Fig. 196. This figure shows

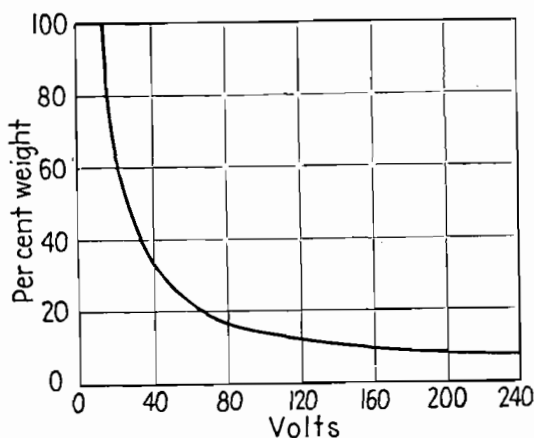

FIG. 196.—Variation in airplane electrical system wiring weight as a function of the supply voltage.

that the wiring weight can be reduced by 40 per cent by using 24 rather than 12 volts. It also shows that for this particular airplane the wiring weight can be reduced nearly 90 per cent by using 120 volts.

The preceding statements hold true when only the distributing system is considered, but there are other considerations involved in the weight of the over-all system. The weight of load equipment such as motors and lights is practically independent of voltage; however, this is not true of the battery associated with direct current systems. The weight of a storage battery for a given watt-hour capacity is a function of a constant plus the number of cells. Since the number of cells is a function of the voltage employed, to a first approximation it can be stated that

the weight of a battery is

$$W_b = K_0 + K_2E \quad (212)$$

If it is assumed that the amount of capacity is the same regardless of the system voltage employed, it is evident that the battery weight will increase with voltage. If a curve similar to that shown in Fig. 196 is plotted showing change of system (including battery) weight with voltage, the curve will show a rise at the higher voltages, and one value of voltage will be present which makes the system weight a minimum.

In their study, Grant and Peters investigated the problem of the optimum voltage for airplanes of various classes ranging from the small sport type to a large twin-motored craft. Their conclusion was that 24 volts would be optimum for direct-current electrical systems for airplanes in this range of classification. Data substantiating this conclusion are shown in Table VIII.

TABLE VIII.—COMPARATIVE WEIGHTS OF ELECTRICAL SYSTEMS

	Sport type	Single-seat type	Two-seat type	Three-seat type		Small twin-engine type		Large twin-engine type		
Weight of cable and conduit of 12-V system, pounds	10	20	50	70	100	150	200	300	400	500
Increase in weight if 24-V is used instead of optimum voltage given, pounds	5	2	0	0	3	10	15	30	50	70
Increase in weight if 12-V is used instead of optimum voltage given, pounds	1	5	25	40	65	110	155	245	340	435

In this table it is seen that a 24-volt system is 5 lb. heavier than the optimum-voltage system for the smallest airplane listed; whereas, a 12-volt system would be only 1 lb. heavier than the optimum-voltage system. For the two-seat type

airplane, the weight of a 24-volt system is the same as that of the optimum-voltage system, and for this airplane a 12-volt system would be 25 lb. heavier than if the optimum voltage were used. For the largest airplane shown in Table VIII, the 24-volt system is 70 lb. heavier than the optimum-voltage system, but a 12-volt system would be 435 lb. heavier than the optimum system.

It can thus be seen that for large airplanes a 24-volt system has a great weight advantage over a 12-volt system, and that over a large range of airplane types it is probably the optimum. For this reason it is expected that 12 volts will not be employed in newer designs, and eventually this standard will entirely disappear for the aircraft power supply. For the very small airplane, however, 6-volt systems will probably be used.

By using the method of Grant and Peters, for the DC-4 system, it may be calculated that 24 volts will bring about a system weighing 170 lb. more than the optimum system, but this system will be 740 lb. lighter than a 12-volt system. This 24-volt system is not a very radical departure as far as voltage is concerned from the present system, so few problems that can be classed as strictly new will arise in using it. Attention to the weight figures quoted above, however, indicates that 24-volt systems will be too great a departure from the optimum when airplanes larger than the DC-4 are designed.

Alternating Current for Aircraft.—All direct-current systems, particularly those employing low voltage, have a distinct disadvantage inherently associated with them—they are very inflexible. The equipment used on present-day airplanes requires voltage ranging from 1.5 to 1,000, and higher values would have been used were it not for the difficulties encountered in obtaining voltages with such magnitudes. With direct current as the primary supply, voltages with magnitudes differing from that of the supply can be secured only by either power-consuming resistors or heavy, and often inefficient, rotating machinery. As the demand grows for more and more voltages of diverse values, the more advantageous becomes alternating current because of the ease with which it can be converted to any desired voltage value. The highly developed electronic devices readily permit the conversion of this power to direct current or they provide for its flexible and easy control, yet

they cannot be used with low-voltage direct current. For several years, alternating current has been provided in small quantities on board aircraft, and it is evident that the future aircraft can avoid the use of alternating current only at a disadvantage in both facilities and weight.

Beginning about 1934, both military and commercial interests considered the use of alternating current for aircraft power supplies. Apparatus was designed and installed on certain military crafts as well as on the experimental model DC-4 air-

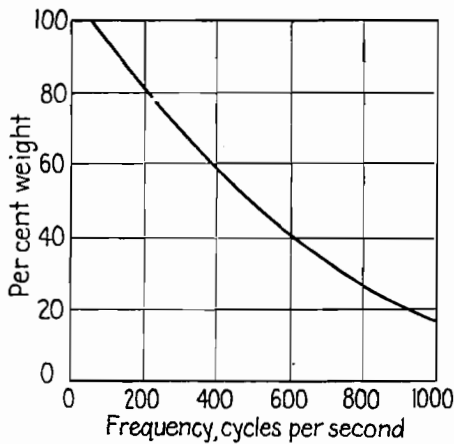

FIG. 197.—Relative weights of transformers constructed for various supply frequencies.

plane, so a comparatively large amount of information dealing with this subject is available(5).

In considering the use of alternating current for aircraft, one of the first considerations is the choice of frequency. Frequency has a direct bearing on the weight of transformers. Referring to Fig. 197, the percentage weight of transformers is plotted as a function of frequency for transformers having equal output ratings. If the weight of a 60-cycle transformer is considered as being 100 per cent, the weight of a similar transformer at 400 cycles will be only 59 per cent, at 800 cycles 27 per cent, and at 1,000 cycles 18 per cent. Within practical limitations this law remains continuous to very high frequencies. It has further been shown that transformers at higher frequencies can be constructed so that their efficiencies are greater than lower

frequency transformers(6). As far as transformers are concerned, the higher the frequency, the greater is the weight advantage.

Frequency does not directly affect the weight of motors. For a given speed, similar motors will have the same weight regardless of frequency. High-frequency motors, however, have higher synchronous speeds than low-frequency motors, and if this factor can be utilized, lighter motors for a given horsepower rating can be produced. If the motors are to be of the split-phase type, securing the additional phase from a capacitor, the weight of the capacitor will be a function of frequency. Low-reactance capacitors are required for high-torque split-phase motors, and, naturally, the higher the frequency, the lower is the reactance for a given size of capacitor.

Radio-equipment weight is affected only by the weight of the rectifier supply. The weight of the reactors used to filter out alternating-current ripple from the power supply is reduced for higher frequencies. It has been found entirely feasible to prevent any frequency (regardless of its value) from creating a disturbance in the output of the radio receivers or transmitters. A number of radio units utilizing alternating current with frequencies in that portion of the audio spectrum to which the ear is particularly sensitive have been constructed, and the elimination of this high alternating-voltage disturbance from the audio system has been found to be entirely practical. Its removal was not extremely difficult and did not require any unusual procedure.

Frequency affects the weight of a conventional three-phase alternator. If an alternator has been previously designed at a lower frequency to have the lowest practical tooth width, the diameter, and hence the weight of the machine, must be increased for higher frequencies. If, however, the inductor-type alternator is employed, this limitation is not present.

The weight of wiring is not affected by frequency. The question of reactance of conductors has been raised, but this reactance is not appreciable (at least for single wires in conduits used as returns). This reactance would become a factor only at extremely high frequencies. The matter of conduit heating by eddy currents at high frequencies has also been investigated, and this effect was found to be negligible.

If conventional squirrel-cage motors are used, the power factor may be low, and it will, consequently, be necessary to provide alternators with larger current capacities for a given power output. This would mean heavier weight. This effect may be corrected by utilizing power-correction condensers. The higher the frequency, the lower will be the weight of these condensers for a given reactance.

Another factor that must be considered in selecting the best alternating-current power supply for use on aircraft is the phase. The greatest effect of phase is on the distributing system. The greater the number of phases, the greater will be the number of conductors, switches, and fuses required. Although the total weight of copper is equal for the same distance of transmission; same amount of power transmitted; a given per cent loss; and the same voltage to neutral for a two-wire single-phase, a four-wire two-phase, or a three-wire three-phase system, the total weight of conductors for a multiphase system will be greater because of the greater amount of insulation and larger diameter conduits required. For example, the weight of insulation on a three-phase system will be about 22.5 per cent greater than that on a single-phase system. With a single-phase system it is convenient to use the airplane structure for a ground return, thus making for a lighter distribution system, but the necessity for keeping a three-phase system properly balanced dictates the use of three conductors.

The Army developed equipment operating on three-phase, 400 cycles, whereas the commercial operators developed equipment for a single-phase 800-cycle system. Both systems utilized 120 volts. Tests indicated that except for certain difficulties encountered in all new equipment the developments were successful. Motors weighing as little as 3 lb. per horsepower were produced.

The prime mover for aircraft alternators requires careful consideration. In the experimental developments previously referred to, separate gasoline engines equipped with constant-speed governors were used to drive the alternators as well as some other accessories such as hydraulic and vacuum pumps. Two gasoline engines were used, each driving a separate alternator. These alternators each supplied 15 kva. to two individual distribution systems. These systems were so arranged that

they could be operated in parallel in event of the failure of one system. The tests conducted with this system were successful in spite of the cramped installation of the small auxiliary gasoline engines (behind the nacelles of two of the main engines). These engines weighed approximately 200 lb. and developed 30 hp.

After these tests were made, it became apparent that

1. It was unreasonable to use a *four-motored* airplane for safety in flight and then to predicate its safety of travel between two points on only *two* gasoline engines.

2. The cost of maintaining a small high-speed gasoline engine equipped with the necessary automatic mixture control, speed controls, and supercharger is almost as much as the cost of maintaining a large 1,400-hp. main engine.

From the foregoing discussion it can be seen that although the cost of maintaining a four-motored airplane equipped with two auxiliary engines is nearly the same as that for maintaining a six-motored airplane, the safety of travel between points was only equivalent to a two-motored craft.

As a solution to the problem of a satisfactory prime mover for driving alternators, the Douglas Company developed a constant-speed hydraulic system. This system consisted of four variable-displacement hydraulic pumps, one located on each engine. The output of these pumps drove hydraulic turbines equipped with constant-speed governors. These turbines then drove the alternators. Such a system might be successful; however, it is complicated, and considerable development will be necessary in order that it reach a state where it can be regarded as entirely trouble-free.

From the experience gained in the past years, the following conclusions can be drawn regarding alternating-current systems for aircraft:

1. Such systems have definite advantages both in weight and facilities offered and will be required for future airplanes.

2. The equipment used with such high-frequency systems can successfully be designed to give good performance.

3. Constant-frequency systems for airplanes of the size now visualized, if the power must be derived entirely from auxiliary power sources, are not practical.

Variable-frequency Alternating-current Systems.—The use of constant-frequency alternating currents for commercial applications on the ground is easily understood. If a transformer is

operated at any frequency lower than that for which it is designed, the exciting currents will be too high, and it will burn up. If it is designed for a lower frequency and operated at a higher frequency, the cost will be higher than necessary. The speed of an alternating-current motor is also a function of frequency, and the extensive use of such equipment would be impossible without a constant-frequency supply.

With the long-established practices of the commercial power industry with which engineers are thoroughly familiar dictating the use of constant frequency, it was not surprising that the men associated with the design of alternating-current systems for aircraft use proceeded on the same basis. The enthusiasm for a system which, for the first time, would supply the facilities so badly needed on aircraft helped to blind these men to the prime-mover problem, and it was not until equipment had been constructed and operated that the problems confronting constant-frequency supplies aboard aircraft were fully realized and the difference between the requirements of aircraft and ground-power systems were entirely appreciated. To the engineer dealing with commercial power, the questions of efficiency and costs are foremost. However, the aeronautical power engineer, although not entirely disregarding economy, has safety and the law of gravity as his most prominent design considerations.

There are other considerations that serve to differentiate the aircraft from the ground-power problem. If the use of power on future aircraft is comparable to that shown in Fig. 194, the greatest portion of this power will be used for transformers and lights. The frequency of the power system has no bearing (within very wide limits) on the operation of lights and other resistive loads; therefore, in so far as the "service" portion of the load is concerned, it can readily be handled by a variable-frequency system. Transformers also can be operated over a large range of frequencies if efficiency is not of primary importance. Motors, however, can hardly be expected to give good operation with this power-supply system. Moreover, the direct-current motor has a very high torque performance, and with the rectifiers that are now available, it is possible to operate all motors from direct current.

Direct-current systems have one feature that cannot be provided with alternating-current systems. It is possible to use a storage battery for a power reservoir. This is a safety feature

of considerable importance from the standpoint of aircraft operation.

The system proposed would consist of a separate alternator driven from each main engine. These machines would have a power rating of about 7.5 kw. and would be designed to operate at frequencies from 300 to 900 cycles and at 120 volts. It is difficult to synchronize alternating voltages when they are generated by alternators driven by various gasoline engines, particularly when the alternator uses only one two-hundredth of the total power output of the engine. This problem is difficult to solve even though the engines operate at relatively constant speeds. This proposed variable-frequency system, therefore, would not deliver all power to a single bus. The loads would be divided into five groups. The loads to be supplied by alternating current would be connected to one of four buses. Associated with each bus and with each alternator would be a high-pass relay. If the frequency of the alternator connected to that particular bus failed or its frequency dropped below 300 cycles, the bus would be immediately disconnected from the faulty alternator and connected in parallel with one of the other buses. This process would be continuous so that in event of failure of three alternators all buses would be paralleled and connected to the remaining operating alternator. Each of these buses would supply one group of loads and, in addition, connect to a rectifier that would supply a fifth bus and charge a battery. To this fifth bus would be connected the loads represented by the 7.2 per cent in Fig. 195. In addition, one radio unit might be connected to this bus. Such a system should provide adequate power and a very high margin of safety.

All the facilities that could possibly be desired are provided with this system. Thermionic devices can be used for regulators, and in this manner the use of the mechanical voltage regulators can be avoided. Voltages of any magnitude whatsoever would be available. All motors would give good performance since they would operate from direct current. Since this direct current is low voltage, small switches could be used for controlling it. The higher voltage alternating current, by virtue of its passing through zero every cycle, could be controlled by similar switches.

It is estimated that the power-generating system should weigh only 15 lb. per kilowatt as compared with the 19.8 lb.

per kilowatt for the 24-volt system previously discussed. Power for the radio units would be supplied by rectifiers deriving their power from transformers having about 70 per cent of the weight of 60-cycle transformers. The saving in wiring weight would be great. It is estimated that for an airplane having a gross weight of 100,000 lb. the wiring system would weigh 350 lb. less than that of a 24-volt system.

No work is in progress on the system just described. Since the necessity for alternating current on large future aircraft seems evident, the discussion of the variable-frequency system was presented as one possible solution to the problem.

Bibliography

1. SANDRETTO, P. C.: Aircraft Electricity as the Airline Operator Sees It, *S.A.E. Jour. (Trans.)*, Vol. 48, No. 4, p. 154, April, 1941.
2. ESHBACH, OVID W.: "Handbook of Engineering Fundamentals," Sec. 8, p. 13, John Wiley & Sons, Inc., New York, 1936.
3. ESHBACH, OVID W.: "Handbook of Engineering Fundamentals," Sec. 11, p. 59, and Sec. 11, p. 50, John Wiley & Sons, Inc., New York, 1936.
4. GRANT, VERNON H., and MELVILLE F. PETERS: Determination of Optimum Voltage for Airplane Electrical Systems, *Elec. Eng.*, October, 1939.
5. SANDRETTO, P. C.: AC For Aircraft, *Aviation*, June, 1939, p. 30.
6. ALEXANDERSON, E. F. W.: Magnetic Properties of Transformer Iron at Frequencies up to 200,000 Cycles, *Trans. A.I.E.E.*, Vol. 30, p. 2447.
7. HOLLIDAY, T. B.: Application of Electric Power in Aircraft, *Elec. Eng.*, May, 1941.

CHAPTER XII

CONSIDERATIONS IN AERONAUTICAL-RADIO-SYSTEMS DESIGN

The term "systems engineering" is used to describe the problem involved in obtaining a desired operation from a group of apparatus when each unit of the group is, in itself, a satisfactory operating unit. This term originated with telephone engineers who first realized the difference existing between individual units operating satisfactorily and a group of units so connected that they gave the desired results. A simple example to illustrate this problem is a group of apparatus consisting of a radio transmitter and receiver operating on the same frequency. If the transmitter is turned on, the receiver cannot receive, yet transmission and reception is desired. A "system" must then be devised by which the transmitter will transmit when the time to impart information arrives and the receiver will receive when information is being transmitted from another source.

If the apparatus consists of a single receiver, the total systems problem would be about as follows:

1. How shall power be applied to place the unit in operation?
2. How shall the necessary radio-frequency power be supplied to the receiver?
3. By what means shall the audio waves of the receiver be converted to sound waves, from which the operator can secure the necessary intelligence?

The first question may be answered by installing a switch on the panel of the receiver, but it is necessary to determine whether the switch should be of the single-pole, double-pole, or other type. Perhaps, however, the switch should be located at the radio operator's position, which is some distance from the receiver. This now involves the question of whether to place the switch in the primary or secondary of the power system (assuming that a primary and secondary exists). Still another solution, if the operator is separated from the apparatus by a

greater distance, is to use a relay and locate a switch to supply power to the relay which will in turn close the proper receiver power circuit. In order to do this it is necessary to supply primary power to the relay, and the question of the power source to be utilized for this application arises. If the receiver is located over a long telephone line and it is necessary to accomplish other switching functions over the line, the problem of turning on the receiver is more complex, and the operation must now be considered in relation to what other functions the line must perform.

Thus, it can be seen that there may be numerous systems considerations attending the operation of even a single radio unit. It is believed, however, that the three questions above form the skeleton for practically all radio systems considerations. The greater the number of units involved and the greater the number of apparatus users, the more complex will be the systems problem. All systems problems relate specifically to a given set of apparatus units and conditions. This chapter, therefore, can serve only to discuss some of the considerations and give examples of how past problems have been solved, with the thought that the principles involved are applicable to problems that may present themselves in the future.

Another way of defining systems problems is that they are those problems involved in the installation and operation of the equipment. One of the first of these problems encountered on aircraft is that of reducing the disturbances in the radio and audio equipment resulting from the use of other electrical apparatus on the airplane.

Aircraft Noise Suppression.—These electromagnetic disturbances are generated by the following sources:

1. Ignition system
2. Electrical system
3. Intermittent contact between various portions of the airplane's structure

These classifications do not include atmospheric or precipitation static.

Airplane-engine ignition is usually accomplished by two magnetos per engine, each attached to an independent set of spark plugs. These magnetos are generators having permanent magnet fields and two armature windings. A breaker point in

series with the primary operates to set up a high voltage in the secondary. The magneto also includes a means for delivering the secondary voltage to the spark plug on the proper engine cylinder. The high ignition voltage generated by the method described will have a very steep wave form; hence, it will have harmonics over a very wide frequency spectrum. Measurements have indicated energy with imperceptible diminution throughout the range from 100 kc. to 300 megacycles.

To stop the generation of this noise would mean the destruction of effective ignition; hence, this noise must be allowed to be generated but prevented from interfering with radio reception. In order to do this, the ignition system is "shielded," that is, it is housed as completely as possible in a metal container. The theory of shielding is well known(1). Briefly stated, the electromagnetic wave (of interfering energy in this case) sets up currents in the shields. The currents flowing in the shield in turn set up a magnetic field having a direction opposite to that of the field inducing the shield current. If the resistance of the shield is zero, the magnitude of the field set up by the shield currents will be equal to the field that induced this current; hence complete cancellation results. Making the shield resistance zero, particularly at radio frequencies, is not possible, so one shield seldom serves to completely obliterate all traces of interference; however, the attenuation must be sufficient to reduce the noise to an unnoticeable level.

The metal container for the ignition system consists of a partial form which fits over each magneto, a metallic hose which fits over each wire from magneto to spark plug, and a special shielding cap which fits over each spark plug. Each magneto has a wire that connects from the primary winding to a switch in the cockpit. By grounding this wire, the primary is short-circuited and hence the magneto fails to function, thereby stopping engine operation. Measurement with an alternating-current voltmeter between this wire and ground will show about 150 volts (r.m.s.). This wire is one of the most prolific sources of ignition noise. It apparently carries the radio-frequency currents generated at the magneto to the remainder of the airplane's electrical system where it is radiated. A good precaution against ignition noise consists in running this wire in a conduit separate from those that carry other electric currents. At

ultra-high frequencies it has been found advisable to include a filter consisting of a series choke of about 6 microhenrys and two 0.005- μ f condensers in each of these magneto leads. The condensers are connected to ground from either side of the choke coil.

Under electrical-system noise can be included the noise caused by vibrating voltage-regulator contacts and by the various direct-current motors on board the airplane. In general, these noises, although they originate from transient sources, are not so intense as those from the ignition system because they have, as a source voltage, only 12 to 24 volts, whereas the ignition system has as its source voltage, 150 volts. Further, the ignition-supply system has as its purpose the generation of these high voltages; whereas, in the case of other electrical units, the generation of these transient voltages is incidental to their operation. It can be shown(2) that for transients to be generated, the following equation must be satisfied:

$$\frac{R^2}{4L^2} < \frac{1}{LC} \quad (213)$$

In this equation, R is the resistance, L the inductance, and C the capacity of the circuit. If C is made very large by the addition of a condenser across the terminals of the electrical unit, $1/LC$ can be decreased to a value where it is smaller than $R^2/4L^2$; hence, the transient generation will be stopped. Small radio-frequency filters located in the radio units in series with each wire (power, volume control, audio output, etc.) leading out of the radio units sometimes aid in the reduction of this noise.

The electrical systems used on commercial airplanes are surrounded by a large amount of metal shielding which helps to reduce the interfering noises described above; but this shielding is installed largely for convenience in the construction of a permanent electrical system rather than for the purpose of eliminating electrical interference.

Bonding had its origin with the fabric-covered airplane. These airplanes were constructed with various metallic members (many of them steel), and good electrical contact seldom existed among all members. Because of this poor contact, various voltages developed on these members, which equalized during

certain airplane movements to produce annoying "clicks" in the radio receivers. Bonding consisted of securing copper braiding between the various members so that they assumed a common potential and formed a plane of neutral voltage. With the coming of the all-metal airplane many of these bonding practices continued to be used although their necessity is subject to question. Good bonding, however, must still exist between the tail surfaces and the fuselage, between the engine ring cowls and the engines, and between the gas tanks and the fuselage. The gas tanks are mounted to the airplane by means of leather straps, and bonding is necessary to prevent sparks which might cause an explosion of the gasoline fumes. The tail surfaces are large and are prone to take on high charges which can discharge to the fuselage and cause an interfering wave train. Because the ring cowls are located over the spark plugs, if not bonded, they will act as antennas for the ignition system.

Antenna Facilities for Aircraft.—The antenna requirement of the various apparatus units on aircraft has, in general, been so different that the best solution seems to be individual antennas for each facility. This process has simplified the antenna-systems problem.

The single exception has been the antenna used for communications. This antenna has always been used for both the transmitter and the receiver; however, the switching problem involved in this application will be covered in the next heading. As the number of antennas has grown, the more incentive there has been for utilizing the same antenna for several purposes.

One of the first applications of antenna switching, other than the transmitter-receiver switching previously mentioned, was used when a fourth unit was added to the complement of aircraft radio equipment. This was the so-called "emergency" receiver which came to be known later by the more appropriate name of "auxiliary" receiver. The receiver was a two or more band device intended for use either as a range or a communications receiver (in event of failure of either receiver). In order not to increase the number of antennas, this receiver was arranged with a relay so that it would operate from the range antenna. The switching was accomplished by means of a single relay operated from a switch in the cockpit (see Fig. 198). This relay transferred the range antenna to either receiver in accordance

with the wishes of the pilot. This system, however, did not provide a full emergency arrangement, because if the range antenna were lost, both receivers were disabled. The next step was the inclusion of a hand-operated switch that allowed the operation of the emergency receiver from either the transmitting or range antenna.

It was very desirable that this receiver should be capable of operating from the transmitting antenna because its sensitivity was rather low, and the added pickup from the long transmitting antenna was helpful. Another consideration, however, entered when this was done. As mentioned in Chap. II, an antenna must have proper characteristics or the range courses will be distorted. The transmitting antenna was satisfactory for range flying only when at a distance from the range transmitter, but

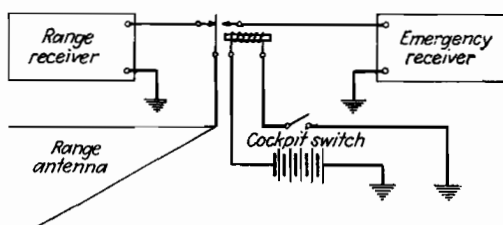

FIG. 198.—Simple antenna system for emergency and range receiver.

when close to the transmitter, its characteristics were not satisfactory. At about this period the advantage of operating this receiver simultaneously with the range or communications receiver, rather than as a substitute for these, became apparent, so a second antenna similar to the range antenna was added. The operation of this receiver from either the communication or its own antenna was still desirable; however, since the communications receiver had to remain in operation at all times, it was not possible to transfer the antenna, and connection was made in parallel. A switch operated by a remote control acted to introduce a small condenser across the antenna which served as a substitute for the capacity of the auxiliary receiver when this receiver was removed. The switching now involved the transfer of the auxiliary receiver between its own and the communications antenna.

The next step in the systems development was caused by the introduction of a loop antenna to normally connect to the range

receiver. This antenna is, of course, very necessary when attempting to receive under precipitation static conditions. If precipitation static prevailed and the range receiver had failed, the auxiliary receiver could not serve a useful purpose unless it was possible to connect it with the loop antenna. The necessary antenna connections, then, were as follows for the auxiliary receiver:

1. On auxiliary antenna
2. On communications antenna
3. On loop antenna

For the range receiver the connections were as follows:

1. On the range antenna
2. On the loop antenna

It can be seen that the number of combinations of the various connections mentioned above is great. Switches had been added as the demand for the new connections increased, and their use was very confusing. After they had been operated, some thought was necessary before the connections prevailing could be determined. The total combinations were as follows:

1. Range receiver on range antenna, auxiliary receiver on auxiliary antenna
2. Range receiver on loop antenna, auxiliary receiver on auxiliary antenna
3. Range receiver on range antenna, auxiliary receiver on communications antenna
4. Range receiver on loop antenna, auxiliary receiver on communications antenna
5. Range receiver on range antenna, auxiliary receiver on loop antenna

The best solution to this problem was the use of a rotary-type switch having five positions labeled in accordance with the five combinations listed above. It is necessary that various elements be switched during a portion of the selections and that they not be switched during other portions. In addition to the switching of the antennas, it is also necessary that unused antennas be grounded when the receiver is used with the loop. The rotary switches available are capable of having added to them any number of independent contact blades accomplishing various switching functions; hence, they make ideal switches when operated in conjunction with a series of relays. The use of

relays in aircraft installations is to be avoided, but in much systems work they become the sole solution, and the problem then involves the design or selection of a chatter-free unit. A schematic outlining the various connections for the antenna switching discussed is shown in Figs. 198, 199, and 200.

A method to be preferred to the use of switches and relays above described when multiple antenna operation is desired is the use of radio-frequency filters and networks. The use of this principle with an ultra-high-frequency loop antenna has already been described in Chap. III. Naturally, the greater the

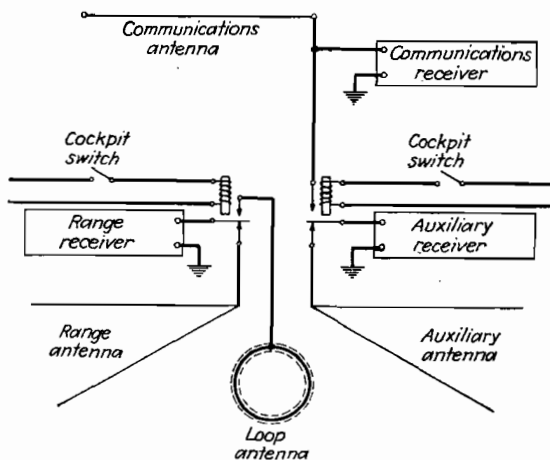

FIG. 199.—Antenna system allowing choice of two antennas for the auxiliary and two for the range receiver.

frequency separation existing between the various receivers to be used with this antenna, the simpler is the problem involved. A method for using an antenna with both the range and marker receivers is shown in Fig. 201. In this figure, the antenna used was of the T type. This antenna consisted of a horizontal member suspended below the fuselage of the airplane. In the center of this member, there was attached a leadin which connected to the range receiver. In applying this antenna to the marker receiver also, the antenna was cut in half and an insulator supplied to complete the necessary mechanical support. Two leadins in the form of a twisted wire pair were connected. The other end of this pair connected to a special coupling transformer. This transformer was designed for 75 megacycles; hence, the

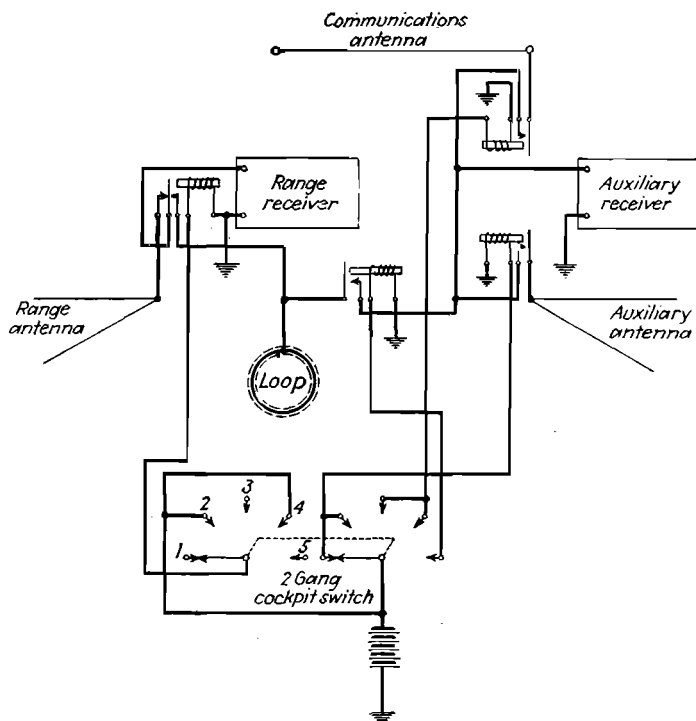

FIG. 200.—Antenna system for range and auxiliary receiver providing five antenna combinations. The numbers on the rotary switch refer to combinations listed in the text.

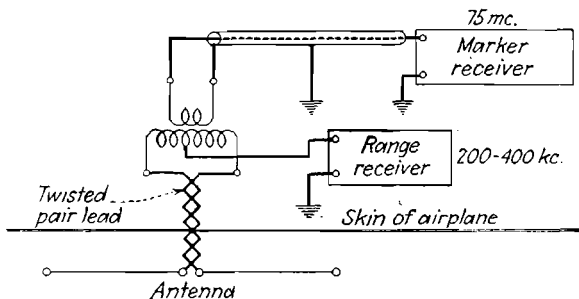

FIG. 201.—Antenna arrangement allowing the use of two receivers with a single antenna.

impedance of its windings was inappreciable at frequencies of the order of 200 to 400 kc. The center tap of the transformer primary was connected to the range receiver; hence, the connection was, as far as the operation of this antenna at range frequencies is concerned, the same as before modification. To this transformer was coupled the marker receiver. The suitability of the range antenna for marker reception is still a matter of debate, but in so far as its ability to provide energy at 75 megacycles is concerned, the method is successful.

Operating the Aircraft Transmitter.—The operation of the transmitter involves a number of interesting systems considerations. These may be outlined as follows:

1. Applying power to filaments
2. Connecting antenna to transmitter
3. Silencing receiver
4. Applying plate power
5. Supplying audio frequencies from the operator
6. Returning monitor signals to the operator
7. Stopping transmission

Applying Filament Power.—Since the transmitter is used for only a few minutes during an entire trip, it would be a waste of power and filament life to keep power applied at all times. Except for indirectly heated cathode-type tubes, then, the filament is turned on just previous to its actual use. The equipment involved in performing this operation may be a simple switch or a switch with a relay. In providing a large number of switches on a small central control panel, the use of a switch large enough to take care of the filament current (which may be as much as 25 amp.) is often impractical, therefore a small switch is used together with a relay. The use of this relay has the further advantage that the necessity for connecting heavy wire between the transmitter and the switch is eliminated.

It is necessary to introduce another problem connected with filament switching at this time. During the time that the high-voltage supply for the transmitter is not in operation, the voltage of 14.2 prevails from the supply line, but when in operation, the high drain of the transmitter plate-voltage dynamotor may cause the line voltage to drop to a value as low as 10. If the filament circuit is adjusted so that the voltage is correct when the line voltage is 10, then the filament voltage will be

excessive during the stand-by period. A means for eliminating this variation is often desirable and will be discussed later, although the necessity for this provision has been minimized by the use of parallel generators (see Chap. XI). To summarize, previous to the time that a transmission is to be made, the pilot operates a switch, thus applying power to the filaments of the transmitter.

Connecting the Antenna to the Transmitter.—The antenna used with this transmitter is shared jointly with the receiver. In order that any calls to the airplane from the ground may be heard, it is necessary that this receiver be in almost continuous operation. This, in turn, requires that the antenna be connected to the receiver at all times except when a transmission is actually being made. In order to expedite the process of making a communication, it is necessary that the antenna connection be restored to the receiver immediately upon the completion of the transmission. This requirement can be met only with a relay to be operated by the pilot just prior to making the transmission. The relay employed, if connected directly to the antenna, has two strict requirements to meet. The first of these is that it be capable of withstanding very high radio-frequency voltages. This requirement is a function of the antenna impedance. At very low frequencies (see Chap. IX), the impedance is very high and voltages of over 5,000 are encountered. At very low frequencies, such as those used by Europeans, the problem becomes more severe. The second requirement is that it be equipped with chatter-free back contacts. These back contacts are used with the receiver, and slight changes in their resistance under vibration conditions cause objectionable noises in the receiver. The cure for this difficulty consists in using a heavy return spring on the relay, thereby greatly increasing the constant pressure. When this is done, it becomes necessary to increase the ampere-turns in the relay. Ordinarily, this means a large relay. In order to avoid this large size, relays are designed with overloaded coils. An extra set of contacts is then added to the relays so that in the period following the pull-in a suitable resistor reduces the relay current to a value consistent with good design. Often an additional requirement is made of the relay. In order that power from the transmitter will not be applied to the receiver, arrangements are made whereby a set of

contacts on the transmitting relay actually turns on the plate power. Thus, no plate power is applied until the relay is closed; that is, until the antenna connection has been transferred. Another precaution taken to eliminate the energy from the transmitter entering the receiver consists of grounding the receiver-antenna terminal with this same antenna-transfer relay.

The previously discussed adjustment for filament voltage is also compensated for by the use of contacts on the transmitter

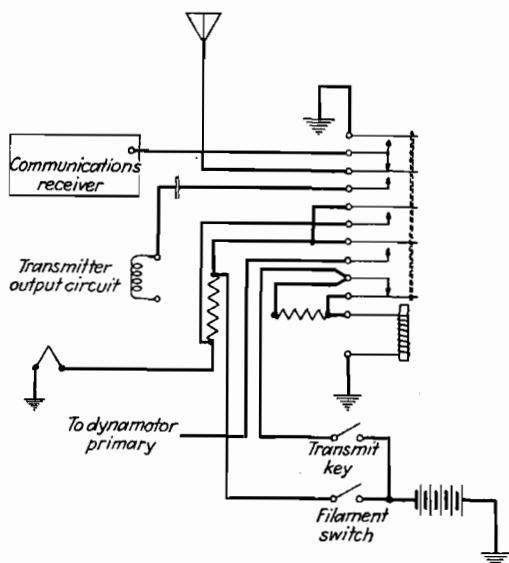

FIG. 202.—Typical antenna transfer relay system used in aircraft transmitter.

relay which short out a resistor in the filament circuit. The transmitter-antenna relay performs the following tasks:

1. Transfers the communications antenna from receiver to transmitter
2. Grounds the receiver-antenna connection
3. Reduces its own current after closing
4. Increases the filament voltage
5. Supplies primary power to the transmitting dynamotor

The complete system is shown in Fig. 202.

A revised form of antenna-relay system applicable where the receiver is always operating on the same frequency as the transmitter and where the input impedance of the receiver is low

is shown in Fig. 203. In this figure the antenna relay is not connected directly in series with the antenna but is actually associated with the terminal of the transmitter's antenna coil which normally would connect to ground through a suitable by-pass condenser. This ground connection is broken and attached to the receiver. The input circuit of the receiver is then connected in series with the output circuit of the transmitter. Since this circuit is series resonant, the impedance presented to the receiver is merely the series resistance of the coil and antenna.

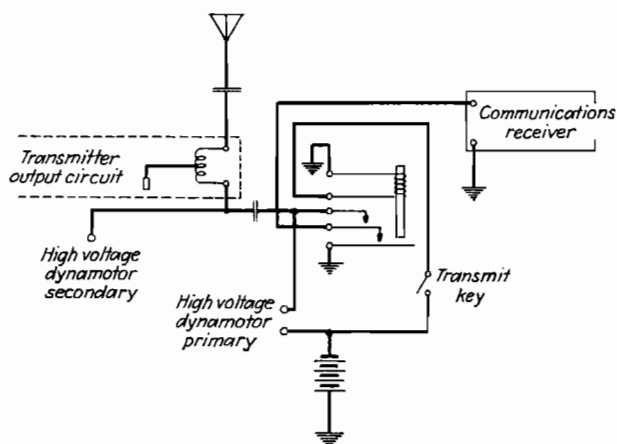

FIG. 203.—Antenna relay system which eliminates the necessity for back contacts to accomplish receiver switching.

The relay does not transfer the antenna when transmitting. When the transmitter button is operated, the lead to the receiver is grounded, and upon further closing of the contacts, this ground is applied to the primary of the transmitting dynamotor. The other terminal of the dynamotor has been connected to the primary power. This sequence of connections assures that the receiver is grounded before transmission can begin. Since there are no back contacts on the relay, the necessity for a high-pressure spring is eliminated. This, in turn, eliminates the necessity for an overloaded relay coil with a resistor. The filament-voltage compensating resistor can, of course, be added to this device in a manner similar to that shown in Fig. 202.

Silencing the Receiver.—The provision made for grounding the receiver-antenna connection in order to silence the receiver has

already been described; however, merely grounding the receiver lead at the transmitting relay is insufficient to prevent the receiver from responding to the strong signals generated by the transmitter, since the transmitter invariably is operating on the same frequency as the receiver. This response would be disturbing to the pilot and might cause regeneration in the transmitter. In order to prevent this, the audio output circuit of the receiver is often silenced. This silencing must be accomplished by some means that does not deliver an acoustical shock to the pilot.

One of the reasons for grounding the input circuit of the receiver is to prevent a voltage from accumulating at the grid of the first receiving tube, which would keep the receiver blocked for a period of time after the transmission has ceased. In spite of the ground supplied at the antenna relay, it is often necessary to add a relay directly at the receiver terminal if the lead between the receiver and antenna relay is of an appreciable length.

With the older type range receiver employing range antennas installed parallel to the transmitting antennas, it was necessary to silence the range receiver as well as the communication receiver. With a modern antenna installation, however, the transmitting antenna is usually located above the airplane whereas the range antenna is below the airplane, and it is possible to make a transmission without interrupting the reception of range signals.

Applying Plate Power.—The application of the high voltage is usually done by an auxiliary relay operating a large solenoid. This solenoid is necessary because of the high current required (see Chap. XI). The solenoid requires a high current so it is operated from an auxiliary relay which also performs several other functions and hence is designated as a systems relay. Power to one terminal of the solenoid is often supplied via the filament connection, so the high voltage cannot be turned on until filament power has been applied. The operation of the systems relay is usually accomplished by means of a small momentary contact button located directly on the pilot's microphone. In some airplanes, provision for this button was made in the wheel. Although the newer systems use a separate set of contacts on this button, the older systems made use of the schematic diagram of Fig. 204 in order to effect a weight saving.

to open the circuit of the carbon microphone in order to stop deterioration of the carbon, but this is unnecessary with the dynamic unit.

Monitoring the Transmission.—An important requirement of a transmitter system is the monitor signal usually referred to as "side tone." This monitor signal is merely the audio signal from the microphone connected back to the headphones of the speaker. It acts as an automatic volume control. Since the ears of the pilot are covered and cockpit noises are present, the sounds made by him are masked and consequently do not make a strong aural impression on him. Under such conditions a person tends to shout. By returning a certain amount of this audio power to the headphones, the speaker lowers his voice until

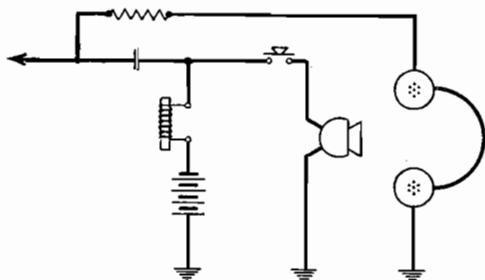

FIG. 205.—Simple sidetone system.

the amount of signal heard is comfortable to his ears. This system, then, acts as an automatic input-level control. There are several ways in which this audio power has been secured. The simplest method was the use of a resistor attached to the microphone circuit. This method is illustrated in Fig. 205. It has the disadvantage that the amount of audio power supplied is limited, so the second method involved the use of the last audio stage of the communication receiver as a side-tone amplifier. This method is shown in Fig. 206. When the systems relay closed to make a transmission, a relay in the receiver silenced the next to the last audio stage, and the microphone introduced a voltage to the last audio stage. This stage was connected to the headphones and so delivered the desired audio power. This system was satisfactory in so far as its ability to produce sufficient audio power was concerned; however, the functions of the receiver and transmitter became more interrelated.

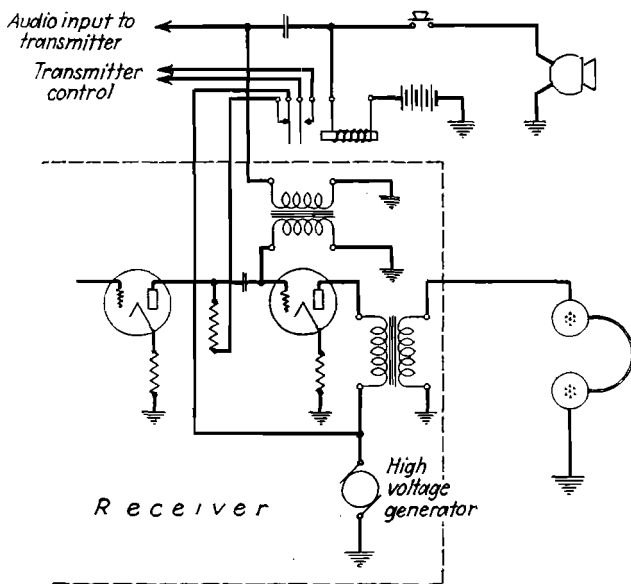

FIG. 206.—System utilizing last stage of communications receiver for amplifying side tone.

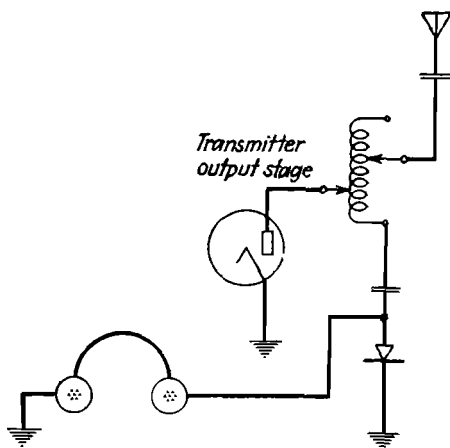

FIG. 207.—System for obtaining side-tone from rectified transmitter output.

Some of the newest systems secure side tone from an audio-amplifier stage in the transmitter or by means of a separate amplifier which is a part of the interphone system to be discussed later.

One of the systems for producing side tone and intended also as a criterion of transmitter performance consists of a rectifier associated with the output circuit of the transmitter. The output of this rectifier (which may be of the dry-disk type) is connected to the headphones. Such a system is shown in Fig. 207. This system produces no signal unless the transmitter is actually producing properly modulated radio-frequency output. Associating the radio-frequency output of the transmitter with an audio system is not preferred by many designing engineers.

Stopping the Transmission.—It would seem that the process of stopping transmission would consist merely in restoring to normal the press-to-talk button on the microphone or wheel; however, this is not the case. It is true that the act of restoring this button to normal is one portion of the process; however, it is necessary that the transmission stop instantly and that the receiver be immediately ready to receive. These requirements are necessary in order that the conversation between the two parties involved may take place without an appreciable break. In order to meet the demands outlined, several circuit elements must be considered. As the power is removed from the systems relay and the transmitting-dynamotor primary solenoid opens, the transmitting dynamotor coasts to a stop. This means that the secondary voltage from this dynamotor does not immediately return to zero, but it gradually decreases from normal value to zero. So long as this voltage has an appreciable value, the transmitter will continue to have output that can be heard in the receiver and that will produce interference. One solution to this problem consists in opening the field circuit of the dynamotor with an additional contact on the solenoid. This, however, is not always a sufficient solution. Filter condensers often store sufficient energy to provide a troublesome after-transmission. A satisfactory solution consists of grounding the transmitter crystal or disabling the oscillator by some other method. The actual mechanism consists of an additional relay associated with the oscillator circuit, or an additional contact on the antenna relay.

Audio-output Systems.—The first installation of radio aboard commercial transport aircraft consisted of a range receiver, a communications receiver, and a transmitter; therefore, the choice of receiving equipment available to the pilots was limited. One pilot could listen to the range receiver while the other listened to the communications receiver. In working an avigational problem, it was possible to disregard the communications receiver and listen only to the range receiver. Soon, however, the importance of information concerning momentary changes in the "ceiling" during landing procedures became evident, so it was desired that a facility be available that would allow one pilot to listen to both receivers while the other listened to only a single receiver. Naturally it was not possible to do this without both receivers being heard by both pilots. This was because the receivers were equipped with a single audio-output system, and the selection of a receiver consisted in paralleling its output with the headphones. During this process, if the second pilot had previously selected a receiver now chosen by the first, the headset of the second pilot would be paralleled with whatever facility the first now chooses. This was not desirable because as the number of receivers was increased the number of possible receiver combinations increased, and it became very necessary that independent selection of the receivers by the pilots be possible without any interaction being caused by their choices.

Although it was realized that the requirements outlined would necessitate separate audio amplifiers, the necessity for providing a solution that could be readily applied to the then existing equipment brought forth several makeshift solutions. One of these solutions is shown in Fig. 208. This system consists merely in adding resistors in series with the audio output of the receivers. The voltage from the receiver is attenuated by one of these resistors before it reaches one headphone, but the voltage appearing across the headphone from a second receiver is attenuated by *both* resistors. In this manner a measure of output segregation is obtained. The amount of segregation possible is contingent on the magnitude of the various impedances involved, but an inspection of the circuit would lead to the conclusion that six decibels would be a reasonable value to expect.

A method sold commercially for application to receivers is the system well known in telephone practice. This is the use

of a balanced bridge circuit known as a "hybrid" coil(3). The arrangement of this circuit is shown in Fig. 209. The theory of this system will not be discussed; however, elimination of

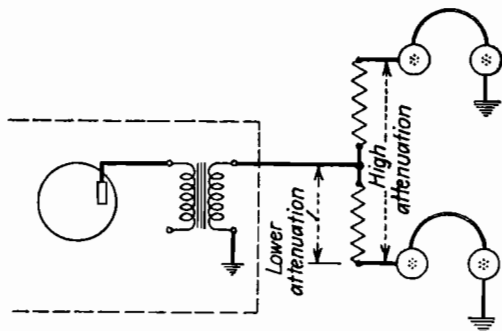

FIG. 208.—Method for obtaining a certain amount of isolation between headphone connections.

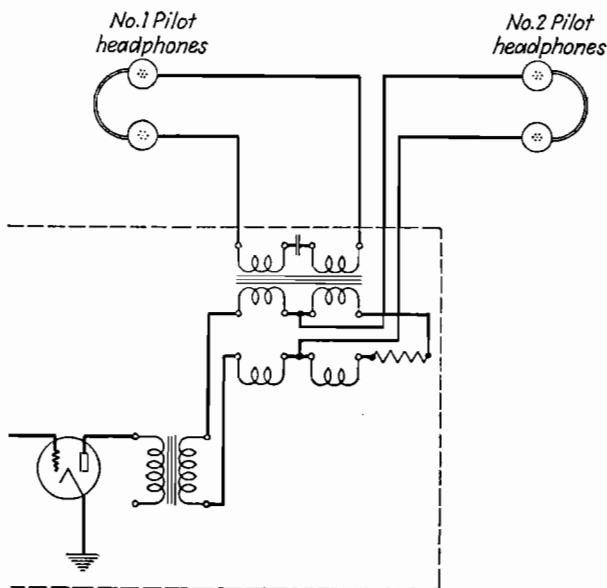

FIG. 209.—Dual audio-output system using a hybrid coil.

reaction depends on the accuracy with which the bridge balance can be maintained. This balance can be made very accurate for a single load, and discrimination of the order of 30 db is possible. Under conditions of changing loads, however, an

accurate balance is impossible, and discrimination of the order of 15 to 20 db is the figure usually measured in practice.

The simplest method to apply to a new receiver is the inclusion of two output-audio stages. This method is depicted in Fig. 210. The output of one of these audio stages is associated with a switch available to the first pilot, and the second output is associated with a switch available to the second pilot. Each

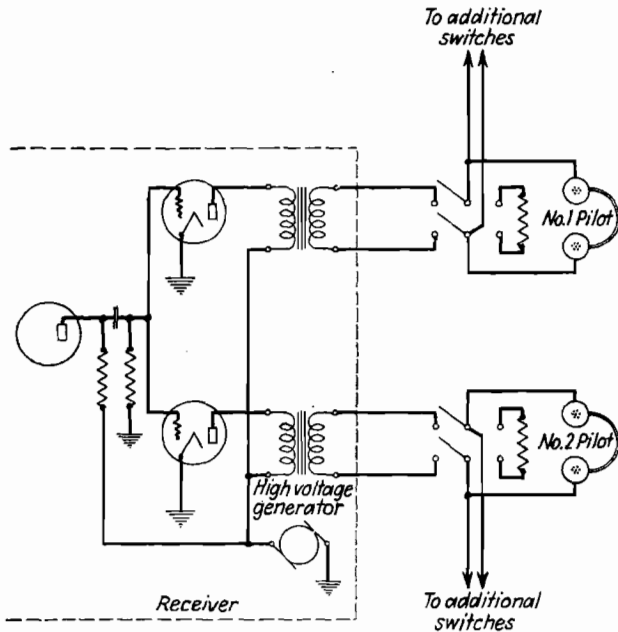

FIG. 210.—Dual audio-output system using a separate amplifier for each channel.

receiver is equipped with these dual stages; consequently each pilot may choose whatever group of receivers he desires without in any way disturbing the choice of the second pilot. The discrimination between channels for this type of system is from 40 to 60 db.

A necessary requirement of the switching system is that the level of the audio from any receiver already connected to the headphones will not change as additional receivers are added. This requirement is met with the arrangement shown in Fig. 210 by making each selector switch a double-pole, double-throw unit. The receiver output is connected to one set of terminals and a

resistor to the other set. The headphones are connected to the movable blades. With this arrangement a load of approximately the same magnitude will always appear across the headphones. This is because either the receiver or the resistor is connected across the headphones at all times as there is no "off" position on the switch.

There are several considerations involved in the design of these output systems. Two common systems have been evolved and are known as the "high-level" and "low-level" systems. High-level and low-level refer to the amount of output power available, although the criterion used in determining whether a system is high-level or low-level is not the amount of power that the receiver will deliver, but whether or not an amplifier is used with the system. To explain this statement it is necessary to remember the discussion regarding the compensation required to maintain constant the output of a receiver at a headphone. This requirement demands the dissipation of power approximately proportional to the number of receivers in the system. This statement can be better explained by the following example. Suppose that the required output for one pair of headphones were 500 mw., and a receiver were designed with this as its maximum audio-power output, then when a second receiver was added, either its output circuit or the compensating resistor would absorb one half of the power; hence, additional amplification would be required to bring the audio level to its previous 500-mw. value. To continue with this example, the receiver in the first case cited would be considered as having a high-level system, but if an amplifier common to both receivers were now added, it would be considered a low-level system. If, instead of adding an additional amplifier, the added amplification were secured by merely increasing the power of each of the individual audio stages in the receiver, thereby dispensing with a separate common amplifier, the system would again be referred to as high-level.

From the foregoing discussion, characteristics of dual audio systems may be deduced as follows:

1. The audio-power output required is a function not only of the power desired at the headphones, but is also a function of the number of receivers that are incorporated in the total system.

2. This desired quantity of audio power may be supplied by the individual amplifiers in each receiver, or a common amplifier may be used for amplifying the audio level just before it reaches the headphones. This latter system is shown in Fig. 211.

The last mentioned characteristic of audio-output systems indicates that a choice of two methods for performing a desired result exists, and it is necessary, therefore, that the facts having a pertinent bearing on this decision be discussed. It has been

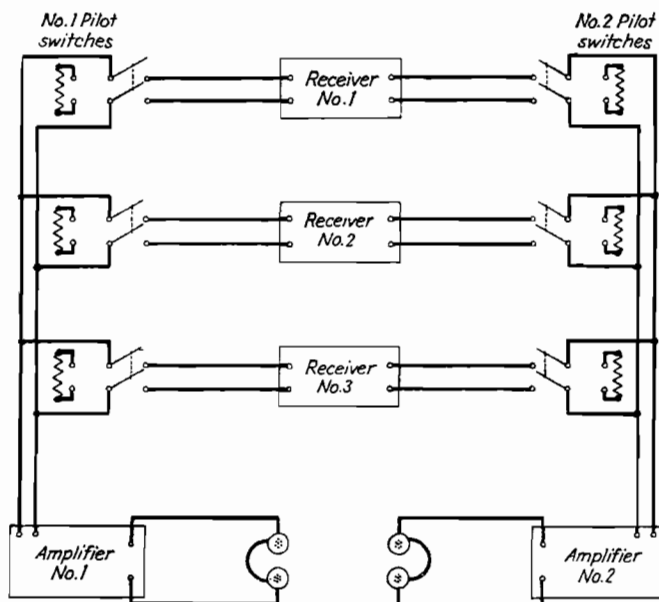

FIG. 211.—Low-level dual audio-output system.

said that the required power output of a receiver is a function of the total number of receivers used in the circuit; hence, it follows that when too many receivers are used the demand for audio power becomes exorbitant. It would not be practical to have each individual amplifier supply this power; therefore, a separate common amplifier is justified. On the other hand, if only a few receivers are to be used, the separate amplifier is uneconomical. The principles involved are clear; however, the point where the powerful individual amplifiers cease to be economical and the separate amplifier is justified may be subject to debate.

An example of the application of the principles cited above is the proposed installation in a large airplane that is intended to be equipped with the following audio-output producing units:

1. Medium-high-frequency communications receiver
2. Range receiver
3. Automatic direction-finder receiver
4. Interphone amplifier
5. Two ultra-high-frequency range receivers
6. Two marker receivers
7. Ultra-high-frequency communications receiver

The units in this list total nine. In addition to the two pilots, this large airplane will carry a third crew member. Audio facilities for this member will be provided by a resistor-compensated switch, which will allow the connection of his headphone in parallel with either pilot's headset. In addition to supplying audio power for this third crew member, it is customary to provide a paralleling switch for supplying audio power to a dispatcher or another pilot who may be riding in the cockpit for observational purposes. This practice is already followed on the airplanes with two members of the crew. If the high-level system is employed and full compensation for level change is incorporated in the circuit, each receiver channel must supply power to 11 power sinks. The older standards demanded that 500 mw. be available for each headphone so that adequate power would be available in event of weak tubes, faulty dynamotors, etc. If this practice were followed, it would be necessary that each individual audio stage supply 5.5 watts. This would be an impractical requirement.

Common practice in high-level audio-circuit design is the use of a 6F6 tube or its equivalent. Such tubes in the previously mentioned nine audio-producing units will consume a total of 88 watts of filament power and 175 watts of plate power. If the compensating resistors used have a resistance value equal to the headphone impedance, the power delivered to each of the three parallel-connected headsets will be 10.2 mw. This is scarcely enough power. If, based on the principle that pentode-type tubes (such as the 6F6) have output impedances three times those into which they actually operate, compensating resistors having values three times those of the headphones are used, the power delivered to the headphones will be 42 mw.

This power may be sufficient, but it is marginal. If the individual amplifier tubes are of the 6F8G type and intended to be used with low-level systems employing a separate amplifier utilizing 6F6 tubes, the total filament power consumed will be 46.4 watts for the filament and 33.5 watts for the plate. This gives, as a total, 71.1 watts compared with the high-level power consumption of 263 watts. This system will produce up to 500 mw. of audio power into each of three head sets. In this system it would appear that the low-level system had an advantage over the high-level method. The low-level system is of particular benefit to receivers that must occupy small chassis.

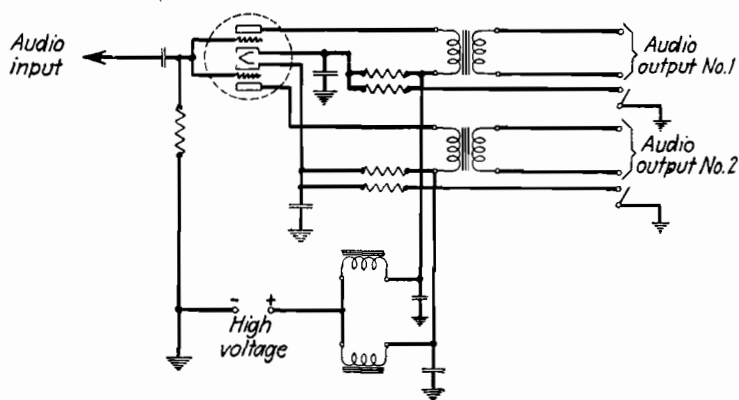

FIG. 212.—Simplified dual audio-output switching system.

In this type of construction, space is at a premium, and it is often not possible to provide room for two individual tubes and a large dynamotor. In order to guard against the failure of the individual amplifier producing a loss of all the receiving facilities, a switch is provided which removes the amplifier from the circuit and connects the headphones directly to the receivers. In such cases it is necessary that a minimum of audio power suffice. It is also possible to remove the compensating resistors from the circuit during such emergency operation.

Figure 211 shows one method of switching when using dual output. The connections from the receiver are brought to the switches with two wires. These wires are in twisted pairs connected to transformer windings, each of which has equal impedances with respect to ground. By this method the cross

talk between the individual circuits is minimized; therefore, this type of wiring is very desirable when large numbers of audio units are used. Connecting to the panel controls the necessary four wires from each receiver becomes cumbersome and is a definite problem in the design of consolidated control panels. The alternate system consists in biasing the individual audio-output tubes (or sections) to the plate-current cutoff point with a switch. This system, which is shown in Fig. 212, reduces the number of wires that must be brought to the switching panel to one per switch. This reduction in the number of conductors required in this panel is important, and the system has the further advantage that the audio wires are confined to the receiver mounting racks and headset jackboxes, thereby assisting in the reduction of wiring system cross talk.

Interphone in the Airplane.—In the early airplane utilizing a multiman crew, the necessity for an effective means of communication between the two pilots demanded the use of an interphone system. As the newer airplanes with their quieter cockpits were introduced, this requirement was no longer of paramount importance; however, these new airplanes added a third crew member in the form of a steward or stewardess, and communications to this third person in the cabin again made an interphone system necessary. With these larger airplanes came the need for more efficient handling on the ground, and their large over-all dimensions brought about the requirement for a means of communication between the pilots in the cockpit and mechanics on the ground. With the coming of the still larger airplanes, a communication system is envisioned that will allow the pilot when on the ground to have a direct wire connection to the dispatcher at the company hangars or to the personnel handling passengers.

The early interphone systems were no more than the side-tone systems. The transmitter filament switch was so connected that it supplied power to the contacts of the systems relay. This power served to operate the antenna relay which in turn operated the transmitting dynamotor via a solenoid. If the microphone button was depressed while the filament switch was on, the transmitter operated, but if this switch was not on, the side tone could be used as a means of communication between the pilots. The first interphone system, then, was supplied by a

resistor from the microphone circuit, as has previously been explained, and later by an audio amplifier in the receiver.

When these simpler interphone systems were extended to the cabin and to the mechanic on the ground, it became possible for the communications transmitter to be operated by others than the pilot. This transmission was, of course, unintentional, being caused by the inherent relation existing between the side-tone and interphone circuits. It became a requirement that one pilot be able to transmit without interfering with the reception of the second pilot, and this was not possible with the earlier interphone systems. With the addition of the second transmitter, it became essential that one pilot be able to transmit on one transmitter while the second pilot transmitted with the second unit. All these developments pointed to an interphone system apart from the radio units. Such systems employing a separate amplifier (which may be the amplifier also used for amplifying the output of the receivers) have been designed. These systems have an inherent advantage in that, although they provide elaborate facilities, their operation can be effected with simplified controls.

Figure 213 shows a separate amplifier system in considerable detail for the purpose of illustrating a typical solution to one of these interphone problems. The system shown on this figure is intended for use by two pilots and a stewardess. There are no switches for the stewardess, but each pilot has two switches in addition to the microphone button. One of these is a rotary switch with four sections and the other a two-bladed ganged switch. The ganged switch positions are marked "Transmit" and "Off." The rotary switch has only two positions and these are marked "Interphone" and "Off." With all switches in the "Off" position, the microphones of the two pilots are connected through the single-pole double-throw switch section of the ganged switches. Each of these microphones connects to separate amplifiers which, in turn, connect to the receiver amplifiers. The outputs of the receiver amplifiers are connected to the headphones worn by the pilots. Whenever one pilot presses his microphone button and speaks into the microphone, voltage is delivered to the grids of both receiver amplifiers, and both pilots hear the voice. If the ganged switch is thrown to the "Transmit" position, the filaments in the transmitter and the

other necessary circuits are energized. When the microphone button is pressed, the transmitter-control relay operates, connecting plate power to the transmitter, and when the pilot talks, audio power is supplied to the transmitter audio-input

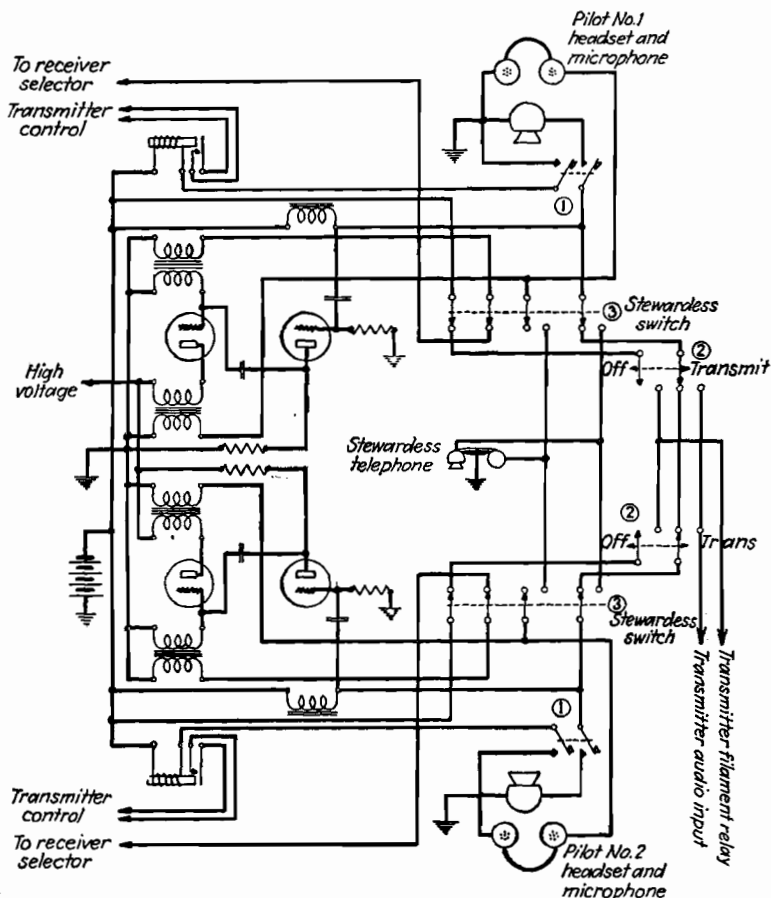

FIG. 213.—Interphone-sidetone system using separate amplifiers.

circuit. The microphone remains connected to the input of the receiver amplifier (via its microphone amplifier); hence, side tone is supplied to the pilot that is speaking. The connection formerly existing between the two pilot microphones is broken when the ganged switch is thrown to the "Transmit" position; hence, the reception of the second pilot is not disturbed by the transmis-

sion. If the second pilot wishes to hear the transmission, it is only necessary for him also to throw his ganged switch to "Transmit," and the parallel connection between the microphones is reestablished.

To talk to the stewardess or to reply to her call (made with a light signal circuit not shown in Fig. 213), the pilot interested throws his rotary switch to the "Stewardess" position. When this is done, the single-pole double-throw section of the rotary switch connects to the stewardess microphone. This same switch opens the circuit between the two pilot microphones so that the conversation will not disturb the reception by the other pilot. The single-pole normally open switch of the rotary gang closes to connect the stewardess handset earphone to the output of the interested pilot's receiver amplifier (which is in parallel with his headphones). One of the normally closed sections of the rotary switch opens, thus preventing the application of transmitter power. This is very necessary in order to prevent the conversation between the pilot and stewardess from being transmitted. Another normally closed section of the rotary switch opens the connection between the receiver-input amplifier and the receiver-selecting switches. This precaution is important in order to prevent the radio reception from being heard in the cabin of the airplane. If the second pilot wishes to join conversation, he merely throws his rotary switch to the "Interphone" position. Notice that it is possible for one pilot to transmit while the other converses with the stewardess.

Interphone between the pilot and the mechanic is achieved by having the mechanic's telephone jack in parallel with the stewardess position. This jack is located on the exterior of the airplane. When the mechanic plugs his handset into the jack, the stewardess handset is disconnected from the circuit. The mechanic signals with a switch button controlling a separate cockpit signal light.

The addition of more men to the airplane's crew further increases the demand for interphone facilities. The system just discussed was designed on the basis that instant communication must be possible between the two men in the cockpit and that conversation to the cabin was of secondary importance, taking place only when other duties were not pressing. With the addition of a third man to the regular crew, it is possible that two

of the men might be interested in a conversation in which the third was not concerned, yet the feature of the circuit discussed, which allows one man instantly and without the manipulation of connector switches to transmit information to the other members of the crew, is still considered important.

A system capable of performing this task has been designed. This system incorporates, in addition to the circuits previously

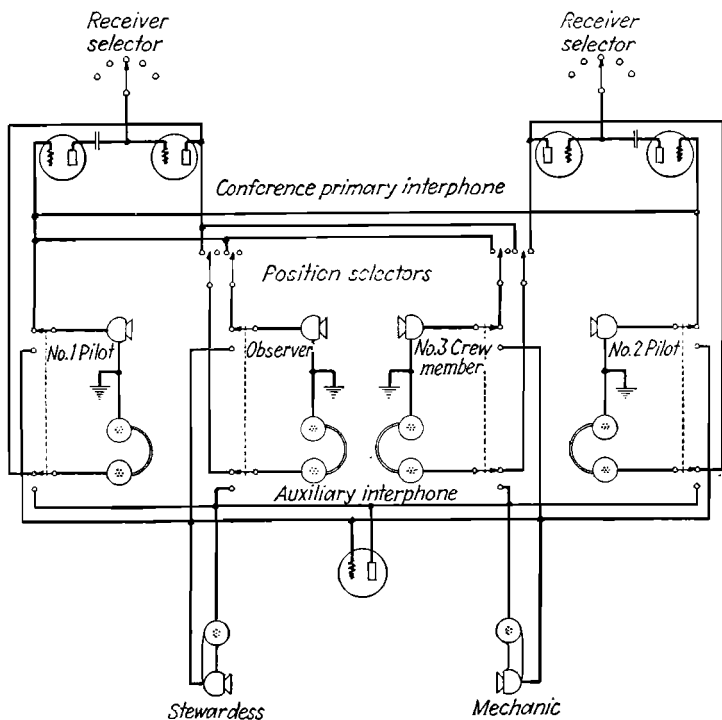

FIG. 214.—Interphone system providing two circuits. One of these is a conference circuit while the other provides auxiliary facilities.

described, a separate and normally unused amplifier. To this amplifier any member of the crew may switch his headset and microphone and conduct a conversation without interfering with the primary interphone circuit. The stewardess and mechanic interphone circuits are made a permanent part of the auxiliary interphone circuit. Signaling is accomplished by a switch that selects the correct signaling circuit and a button that flashes a light. This circuit is shown diagrammatically in

Fig. 214. Reference has previously been made to the method of receiver selection employed by the observer and third crew member. This method is shown in Fig. 214. In order to avoid the confusion that would occur if the third crew member had a separate set of receiver-selecting switches and the receivers had only a dual output system, he is provided only with means for paralleling his headset and microphone across either the first or second pilot's separate audio amplifier. The principle behind

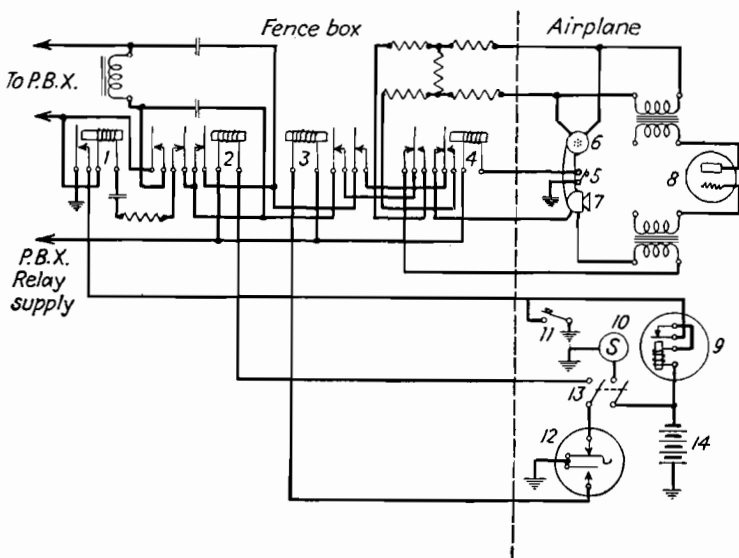

FIG. 215.—Airplane interphone system providing external telephone connection.

this system is that one of the pilots will have selected the facility to which the third member wishes to listen, and if this is not the case, perhaps he will be willing to make the selection desired by the third party. This same system is also applied in Fig. 214 to the observers' facilities.

An interphone system that allows the various members of the airplane's crew to converse with control-tower personnel, passenger agents, dispatchers, and Airways Traffic Control personnel is shown in Fig. 215. This system utilizes a dial-type private branch exchange between various stations about the airport, a relay system located on the fence near the airplane, and the airplane's interphone system. A multi-wire cable was

attached to the fence box and connected to the airplane by means of a suitable multi-contact plug. Referring to Fig. 215, when a ringing tone was placed on the telephone line by a party wishing to contact the airplane, relay 1 (an alternating-current operated relay) closed and operated buzzer 9 in the airplane. In answering, the pilot operated switch 13. This switch closed relay 2 in the fence box so that the circuit between the airplane's interphone system and the telephone line was completed. It also closed a circuit to light 10. This light was in parallel with other similar lights at the various airplane stations and served to indicate that the telephone line was in use. During the conversation, handset button 5 was depressed to make a transmission, and this served to connect the telephone line from the input to the output of the airplane's interphone amplifier by operating relay 4 in the fence box. To initiate a call, the crew member operated switch 13, then dialed the desired number on dial 12. This dial produced line pulses by means of relay 2. Push button 11 was used to signal other crew members that they were wanted on the telephone. This service was provided for all the crew members as well as for the mechanic outside of the airplane. This was done by paralleling a number of airplane units somewhat similar in construction to that shown in Fig. 215. One experimental installation of the system shown in Fig. 215 was made, but no further action was taken. This system, however, must be considered in planning the interphone systems for future airplanes.

Aircraft-radio Power Systems.—Throughout this book reference has been made to dynamotors as the source of high-voltage power required for all radio units. There are, or have been, a number of different units that can be used for supplying this high voltage, and since these are not sources of primary power, they do not belong to the subject discussed in Chap. XI. Their methods of use have a number of ramifications; hence, this subject is properly a systems problem.

The first high-voltage power-supply system employed on aircraft consisted of two or more generators mounted externally to the airplane's structure. These were driven by constant-speed propellers energized by the airplane's slip stream. These propellers had a single blade which tended to rotate about its major axis but was restrained by a spring. This spring arrange-

ment acted as a governor and maintained constant speed. Control of the output of the lower voltage generators was accomplished by a switch connected directly in the output circuit. For the transmitting generators the output control was placed in the field. One method consisted of a solenoid-actuated brush-lifting mechanism. The wind-driven generators did not long remain in service on commercial airplanes. Since they were exposed, the propellers were subject to icing, which hampered their operation. Also, extensive use of this device was precluded because when the airplane was on the ground and its engines were not revolving at a high rate of speed, power was not produced to allow the operation of the radio. The power supplied by these generators was not obtained gratis. The aerodynamic drag caused by them is more than the equal of the power taken by directly connecting the generators to the airplane's engine.

A generator directly geared to the main engine would have the disadvantage common to the wind-driven machine; that is, it cannot produce power when the engines are idle. One direct-driven high-voltage generator system was, however, developed, which circumvented the above-mentioned difficulty. This system consisted of a generator having three windings. One of these was a 1,050-volt generator for the transmitter, and the other two delivered 7.5 volts each. When the airplane was on the ground, a switch connected the two low-voltage windings in parallel and connected them to the airplane's battery. A free-wheeling clutch permitted the disengagement of the armature from the main engine and, hence, the machine operated as a dynamotor. After the main engines were operating at high speed, the two low-voltage windings were connected in series and served to charge the battery. Control of the high voltage from this machine was obtained by a brush-raising solenoid.

The vibrating-reed type converters have been employed in a few aircraft radio units. Where they have been judiciously used, their life has been moderately long. Their weight is low compared with that of a dynamotor. In using them in a radio system, it is not only necessary that they be carefully shielded and filtered, but it is often necessary that iron-core chokes and large condensers be used to prevent noises from entering the audio circuits of adjacent radio units. Because of this filtering difficulty and the maintenance problem involved, the trend

has been away from the use of these vibrators in multi-unit airplane radio installations.

The battery-driven dynamotor is by far the most popular source of radio high voltage for aircraft use. The early high-voltage systems employed a single dynamotor for supplying power to two receivers, and another machine to supply high voltage for the transmitter. The switching of the high-voltage dynamotor has already been discussed. In recent years many radio units have included a dynamotor as part of their standard equipment. That is, the dynamotor is mounted internally in the case of the unit as contrasted with the earlier practice of external machines. This practice provides an individual machine for each unit. The safety factor (in so far as high-voltage supply is concerned) is low per radio unit since the failure of the integral dynamotor disables it; however, the failure of this unit affects only one piece of radio equipment. Since a safety factor for the radio equipment is provided by additional equipments, it can be argued that this factor is high from the standpoint of the over-all system. It is as high as the total number of units. The use of individual machines has the further advantage that design of the radio apparatus is not contingent on the method of using the common dynamotor. It is possible to obtain bias by grounding the negative terminal through a resistor in one unit and to ground it directly in another unit.

The use of external dynamotors in a new system has recently been proposed, and with good reason. Ten small dynamotors supplying 25 watts each will weigh approximately 50 lb. and consume 462 watts. A single machine producing the same output power will weigh approximately 13.1 lb. and consume 306 watts. It is therefore possible to carry two machines—one running and one spare and still save 23.8 lb. and 156 watts. The safety factor would be high, and all radio units would remain in operation if one dynamotor should fail. This latter system has the further advantage that it will make necessary the maintenance of only 2 armatures, 2 sets of bearings, and 4 sets of brushes, rather than 10 armatures, 10 sets of bearings, and 20 sets of brushes. However, if this new system is used, it will be necessary to provide protection against individual radio unit high-voltage short circuits. Since the high-voltage drain of these receivers is low (maximum 100 ma.) and a low-current fuse

does not successfully withstand vibration, the development of adequate circuit protection must be undertaken before this proposed dynamotor system can be applied.

In using high-voltage dynamotors in receivers it is common practice to provide a single primary switch which simultaneously starts all units. This is in contrast to the early practice that made possible the shutting off of unused radio units. A switch is provided on each radio unit in order to remove it from service only in case it becomes disabled. Normally these switches are tied to the "on" position with a piece of wire forming a seal.

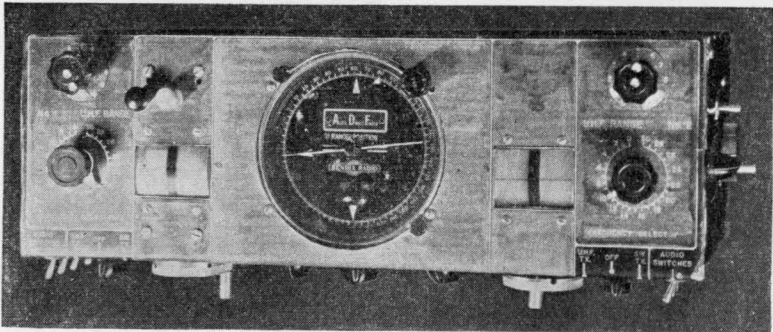

FIG. 216.—Top view of consolidated airplane control panel showing automatic direction finder, azimuth indicator, ultra-high-frequency range station selectors, and tuning controls. (Courtesy of United Air Lines.)

Aircraft Control Units.—Units in the cockpit must be provided for accomplishing the following functions:

1. Tuning receivers
2. Selecting frequency of pretuned units
3. Choosing receiver functions
4. Controlling gain and volume
5. Selecting receiver-output circuits

Besides these function controls, certain indicators such as the azimuth for direction finders, lights for markers, and visual course for ranges are also grouped with radio control units.

The tuning of receivers is accomplished with a pair of gear trains—one located in the cockpit and the other at the receiver. A tachometer flexible shaft connects between them. The speed of the shaft is greatly in excess of the speed of receiver-control rotation in order that backlash caused by the flexible shaft may be eliminated. Early equipments employed mechanical

frequency selectors operated by pull wires from the cockpit; however, the multifrequency units have employed electric drives. The employment of electric drives places the control of frequency in the same category as any other electrical function in so far as control equipment is concerned.

There are several receiver functions that may be selected at will. The range receiver may be tuned or it may be shifted to a fixed tuned frequency of 278 kc. Many of these receivers may be used as a direction finder by manipulating a switch which connects a loop antenna to them. The automatic direction finders also may be used as either manual direction finders or as auxiliary receivers. The selecting of the voice or the range signals with the range filter must be done by a suitable function switch in a control unit. The control of gain or volume is done with a variable resistor unit or ganged units. For controlling volume alone, where gain is not a factor, a resistor switch with taps has been employed. The selecting of receiver output circuits has already been discussed at some length.

Units for performing the above-mentioned functions have in the past been designed by manufacturers and considered as a part of a radio unit. This practice has not been very satisfactory when a large number of radio units are employed. The individual control units are not economical of space and often cannot be located where they are convenient to the pilots. Modern practice has been toward common control units housing all controls and grouping them in a manner most convenient to the users. Where a single unit is not possible, the various controls have been grouped in units as follows:

1. On the ceiling, all tuning and frequency selecting controls
2. In the center (at the airplane control pedestal), the receiver output and gain controls
3. On the cockpit walls near each pilot, the jackboxes containing individual audio controls

Receiver functions are generally divided between the ceiling boxes and the pedestal box. Quick-disconnect plugs are employed whenever possible in order to facilitate changing these boxes. Mechanical plugs for quick disengagement of the tachometer shafts are employed. Often the required number of plug contacts is high, and one unit employs as many as 180 contacts. With this type of unit a jack-screw arrangement is

required in order to effect disengagement. The audio-control system employing a single wire and ground was developed because of the large number of wires required for the control box.

Although the earlier control units have been designed for the radio equipment, newer units are being designed for the airplane. This is logical and follows the practice that has always been used for other mechanical devices on board an airplane. The manufacturers of aircraft engines do not design the throttle handles or their location in an airplane, so by the same reasoning, the manufacturers of radio equipment should not design the radio-control units.

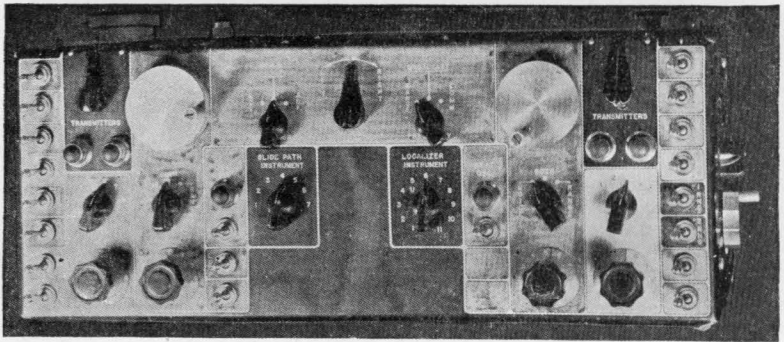

FIG. 217.—Front view of consolidated control panel showing audio selection switching, etc. (Courtesy of United Air Lines.)

Systems for Small Ground Stations.—This discussion will apply principally to ground communication stations, and not to range, marker, or similar types of installations.

Since all ground stations are not alike, they may roughly be placed in two categories. The first of these is the station employed at the majority of the airports where a transport airplane stops. In general, this station is equipped with the following apparatus:

1. A transmitter located locally and usually operating on only two radio frequencies (but not simultaneously)
2. A local radio receiver operating on two frequencies
3. A tunable receiver used to obtain weather information and also to monitor the local radio range
4. Speech amplifier for the transmitter
5. Control panel for all facilities

It can be seen that with only the foregoing apparatus involved, the system problem is comparatively simple. In addition to being able to control the transmitter from the room in which it is located, it is necessary to control it from one or more remote positions. A handset is employed for this purpose. The earpiece of this handset is connected across the receiver output and the microphone to the speech amplifier for the transmitter. The transmitter-control problems are quite similar to those described for the aircraft unit, except that instead of operating a starting solenoid to supply plate power, the control is obtained by a primary contactor in the rectifier primary or an oscillator grid blocking relay. The filaments of the transmitting tubes are generally energized throughout the entire 24-hr. period. The speech amplifier is employed mainly to keep the input to the transmitter constant without the necessity for monitoring. Since the acoustical noise problem is not so troublesome on the ground as it is in the airplane, it is not necessary that a monitor amplifier be used; hence, side tone is usually obtained directly from the microphone. With the coming of the dynamic microphone, this is no longer true, and a separate monitor amplifier used in about the same manner as has been described for the aircraft amplifier has come into use.

Transmitter frequency selection is mechanical and is generally operated with a simple hand lever. It has sometimes been necessary to locate these transmitters a short distance from the control office. When this is done, a motor- or relay-operated unit serves to shift frequency.

One of the additional ramifications attending a ground-station system for a small station concerns the use of a miniature radio-range transmitter. This small transmitter (or localizer as it is termed) is employed as a connecting link between an airport and an adjacent radio airway. This localizer generally has a power output of from 10 to 100 watts and is turned on only when an airplane is known to be in the vicinity. Since identifying signals are not employed with this facility, it is generally necessary to conduct some conversation with it. When this is done, the headphone and microphone are switched to the tunable receiver and the localizer transmitter, respectively. Arrangements are provided which allow listening to both the tunable and fixed receivers simultaneously; however, since it is unneces-

sary to arrange for two men to listen on different facilities simultaneously, dual output is not required in the receivers. It is often essential that one operator located in the station copy the conversation that the second operator is conducting over the radio while listening outside the station for the sound of an airplane's motor.

Systems at Major Air Terminals.—In going from the airline's small communication station to the major radio station, the scene changes from a station operated by a single man to a station with as many as eight operators. Whereas in the smaller station all the radio equipment is within the reach of the operator, the largest portion of the equipment at a major station is located at distances up to 15 miles from the operator. In the same room with the radio operators there may be a large number of teletype machines operating over wire circuits.

From this description it can be seen that the systems problem is greatly different for these two types of stations. At these major stations there are two general types of controls employed. One of these is the plug and jack switchboard, and the other is the console control panel. In the plug and jack board all facilities come to a central board and are switched to the desired operator's positions with plugs and jacks similar to those used in telephone exchanges. This type of control is best suited to stations with more than four operators. This system has the disadvantage that an operator must rise from his seat and go to the board before he can make a selection. In the second type of system, the controls are condensed on a panel, and each operator may choose at will those facilities which he desires. In these control consoles are a number of amplifiers. There must be one amplifier for each facility available. The operator can connect his headset to any or all of these amplifiers. The input circuits to all these amplifiers are paralleled by similar amplifiers in the other operators' consoles. One of the peculiar requirements for the audio-output system is the necessity for splitting the headphones so that one circuit may be connected to one earpiece and another to the other earpiece. This is done to enable the operator to cover two circuits simultaneously. By having the messages come in via different ears, he can concentrate on only the message desired at the time.

The number of receivers available varies. At all major stations the most important receiver of the circuit is located remotely from the airport, but in order to provide a safety factor, another similar receiver is located locally. This means a minimum of two receivers. A local tunable receiver is also provided for monitoring the long-wave control tower and other transmission not directly connected with the regular com-

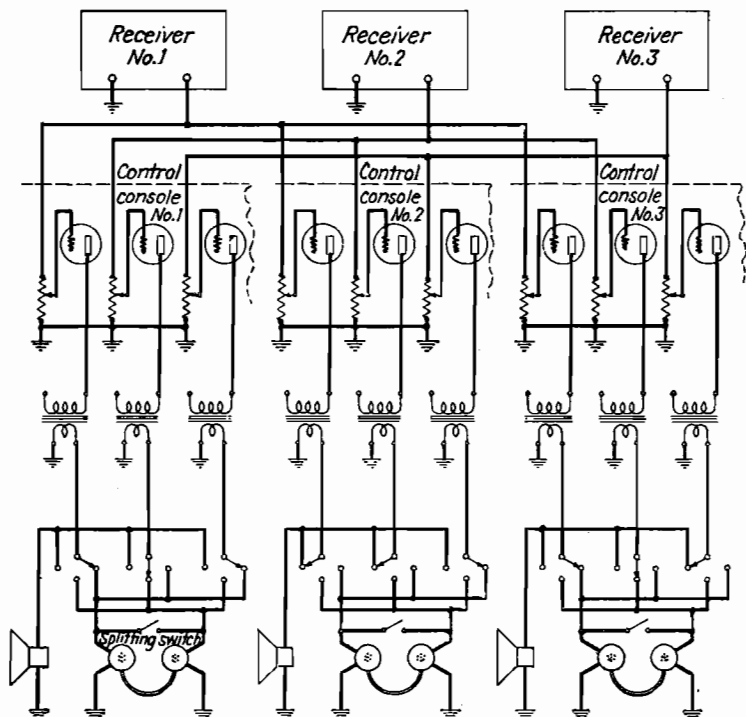

FIG. 218.—Ground-station system utilizing separate console amplifiers for each operator.

munications circuit. Often more than one pair of frequencies is used, so facilities may be provided for as many as four local and four remote receivers as well as the interphone circuit. When more facilities than these are used in one station, the plug and jack board are employed. In addition to providing for the features described above, arrangements are made for switching the receivers to a loud-speaker. A simplified schematic diagram of such a control console is shown in Fig. 218.

The control of remote receivers has been described in Chap. IX. A dial system for changing gain and frequencies is the common method of control. Some of the newer receivers employing very effective automatic-gain-control circuits and carrier-controlled output no longer require manual gain controls.

The problem of controlling transmitters is usually more complex than that of receivers. Controls for performing the following functions are desirable:

1. Connecting power to place transmitter in "ready" position
2. Selecting frequency
3. Turning on carrier
4. Applying audio power
5. Reducing power
6. Resetting circuit breakers

Connecting power to the transmitter is sometimes possible only at the transmitter itself, but it is usually desirable if this function can be accomplished at the operations terminal. In the high-powered transmitters common to the major airline terminals, frequency is selected merely by applying power to the filaments. Turning on the carrier is often accomplished by changing the bias on one of the low-powered radio-frequency stages. The bias is normal during the carrier "on" period and is increased far beyond the cutoff point during the "off" period. This function must be accomplished at the same time that the audio power is applied. The reduction of power is necessary in order to make transmissions to airplanes located on the near-by ramp. This reducing of power is generally accomplished by disconnecting the high-voltage supply to the last stage and modulating one of the earlier stages. The resetting of circuit breakers is necessary because there are periods when momentary voltage fluctuations may cause overloading in the transmitter, which overloading causes the circuit breakers to open. Monitoring of remote transmitters is usually done with the remote receiver, so cessation of transmission is immediately noticed by the operator.

An examination of the above functions indicates that all of them except the application of audio and turning on the carrier may be accomplished with a dial (step-by-step system). The carrier must be turned on instantaneously at the time of making a transmission and turned off directly after it is made; so a dial

system is too slow for this purpose. An extra set of telephone lines (one set for the voice and the other for the carrier control) would be an added expense. One of the methods used consists of a simplex circuit. This circuit is pictured in Fig. 219. It consists briefly of two center-tapped transformers, carrying the audio frequencies to the transmitter. Power applied between the center tap and ground at the operating end of the circuit serves to operate a relay connected between the center tap and ground at the transmitting end of the circuit. This circuit should allow the use of alternating current for control; however, in order that no other transformers will be inserted in the line, it

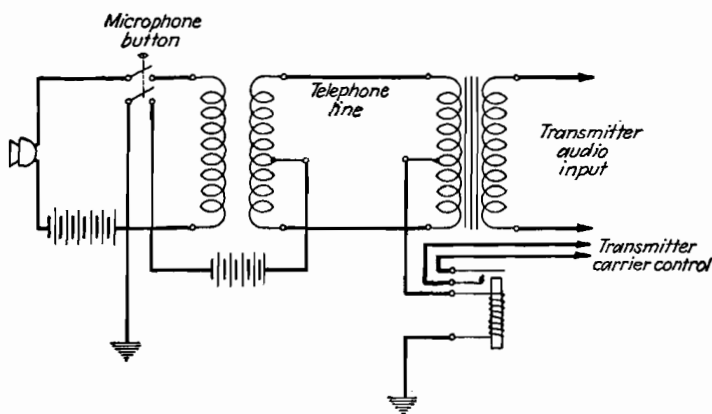

FIG. 219.—Simplex system for performing two functions with one pair of telephone wires.

is necessary to make special arrangements with the telephone company. When this is done, a direct copper circuit exists and direct current can be used for the control. The provision for this direct copper circuit involves an additional line cost. In order to eliminate this cost, a tone-actuated device is applied at the transmitter end of the line. In brief, this apparatus consists of filters, amplifiers, and rectifiers. A tone is applied at the operating end of the line, together with the audio voltage from the operator's speech amplifier. When the voltages arrive at the transmitter end of the circuit, they are separated with filters, and the control tone operates the relays that remove the excessive transmitter bias. This tone is chosen so that it has a frequency below or above the desired speech spectrum. This system is shown in Fig. 220.

At the operating positions, provisions must be made so that all operators can control all the receivers. This can be accomplished by switches that connect the controlling dial to various lines. This same switching process can be applied to the microphone-control buttons and speech-amplifier circuits; however, indicator lights must be used so that all operators know which circuits are in use.

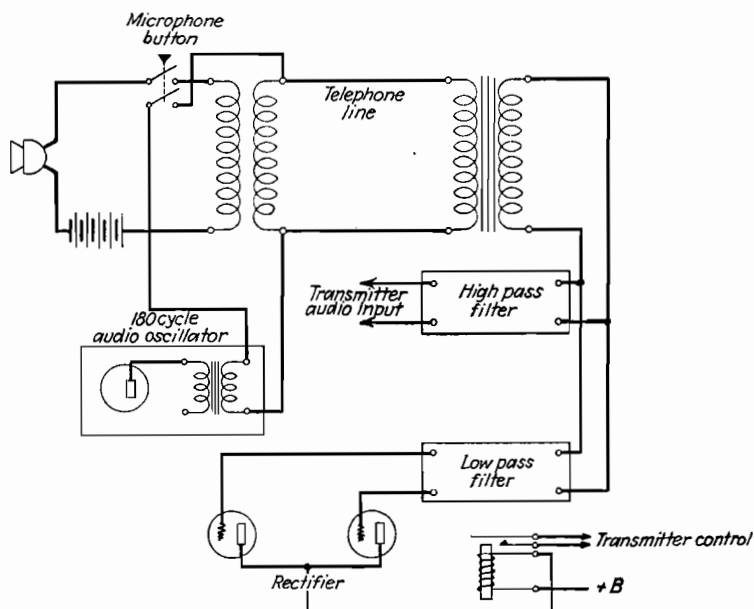

FIG. 220.—Remote transmitter-control system using a tone-operated remote-apparatus controller.

Microphones.—An important systems unit is the microphone. The carbon microphone has been very popular in the past, both for use in airplanes and at ground stations. The chief reason for its popularity was its high output which eliminated the use of high-gain amplifiers. This output is generally considered to be 0.006 watt (zero level) with an output impedance of 100 ohms. The carbon microphone is, however, a square-law device(4) and is prone to distort. Since it is a nonlinear device, it also is prone to overload, and beyond a certain value of input, it does not produce further output.

Another serious objection to the carbon microphone is its maintenance. Since the device is in almost constant use in

ground stations, it tends to wear out and the carbon chamber must be overhauled at frequent intervals. The aircraft-microphone packing problem is more serious than that of the ground-station unit. The vibration to which the aircraft unit is subjected seems to cause packing, and aircraft microphones must be checked at intervals of 1 to 3 months. For these reasons the carbon microphone has been largely replaced in all aeronautical ground stations with dynamic or crystal units. In the airplane

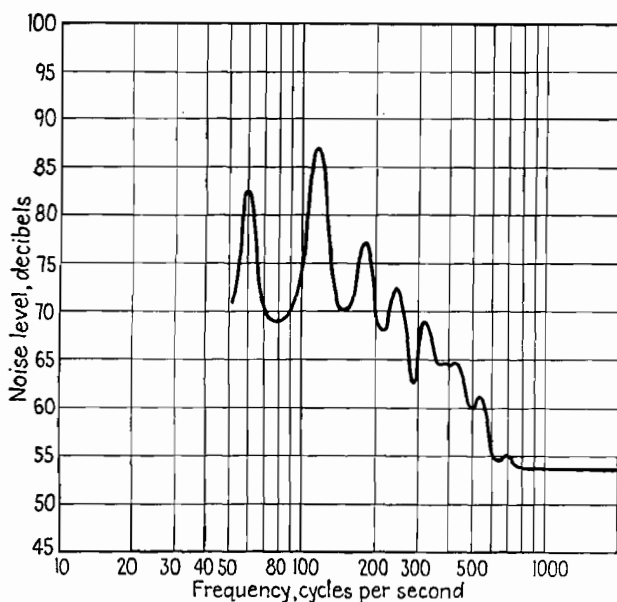

FIG. 221.—Frequency characteristic of airplane noise. (Courtesy of Aviation.)

the carbon microphone is still in common use; however, the installation of amplifiers will also see it replaced.

In both aircraft and ground stations the specifications for the microphones are similar. The ground stations are noisy because of the activities about them, and the aircraft cockpits are noisy because of propeller and engine. The problem of making transmissions in these noisy locations has called for a microphone with limited sensitivity and response. The limited sensitivity makes necessary the use of the microphone close to the mouth, and then the head of the person speaking acts as a noise baffle. The sound impressed by the speakers on the microphone dia-

phragm is considerably more intense than the external sound. The sound present in the cockpit of an airplane is shown in Fig. 221(5). It will be noticed that considerable noise is present below 600 cycles. Since the frequencies making for the greatest intelligibility(6) lie in the range around 1,000 cycles, it is possible to remove all low frequencies and thereby eliminate much of the noise and but little of the intelligibility. The response of a typical aircraft microphone is shown in Fig. 222. The limiting of the response is accomplished by suitable acoustical filters and

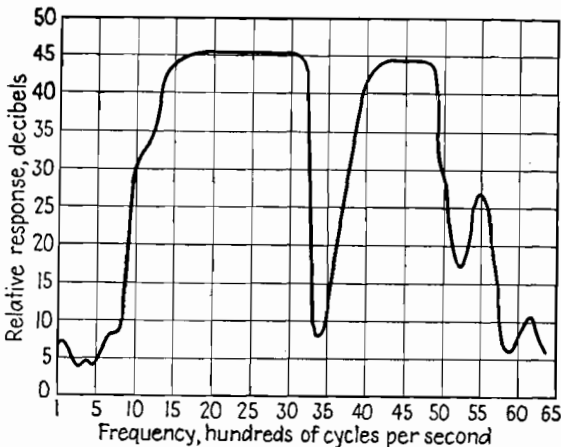

FIG. 222.—Frequency characteristic of aircraft carbon microphone.

resonant diaphragms at the microphones. The acoustical elimination of these extraneous frequencies helps to prevent the microphone from being overloaded with unwanted frequencies. Some of the unidirectional microphones have been tried in place of the close-talking type, but it has been found that close-talking gives the best results.

Headphones.—It has been common practice to use headphones rather than loud-speakers (except as calling devices) in the cockpit and on the ground for the following two reasons:

1. Headphones help eliminate external noises.
2. They assist the operator in concentrating on the information carried over them.

In the cockpit the noisy conditions demanded the use of large amounts of power output from these headphones. Because of this requirement, headphone construction has been rugged.

These headphones are, in fact, small loud-speakers. The operators on the ground, not faced with such noisy conditions, but faced with having to wear the headphones for longer periods, often wear them forward of the ears for comfort and move them into place when it is necessary to listen to a weak transmission. This method of operation necessitates the use of more headphone power than normal, and again the necessity for rugged construction is evident.

Headphones are also designed for the limited response discussed previously for the microphones, but, in addition, they

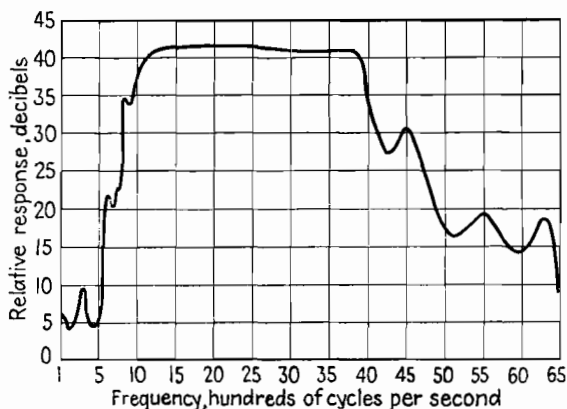

FIG. 223.—Frequency characteristic of aeronautical headphone.

have a novel acoustical filter for another reason. When listening to the usual aeronautical signals, the signal-to-noise ratio is often very low. This means that static is often very high. In order to eliminate the effects of this static on the ear drums, an acoustical filter is constructed around the diaphragm, which limits its output when subjected to sharp wave fronts of the type produced by static. Characteristics of typical headphones of the type described are shown in Fig. 223. The usual aeronautical headphones are designed for an input impedance of 250 or 500 ohms.

Problems

1. Draw a schematic diagram similar to that shown in Fig. 213 but for the control of two transmitters. This system must also include suitable side tone and provisions for interphone to mechanic and stewardess.

2. Draw a complete interphone, side tone, and transmitter control diagram based on the schematic diagram shown in Fig. 214.

3. Devise a method for protecting the common dynamotor power supply described under Aircraft Radio Power Systems.

Bibliography

1. MOULLIN, E. B.: "Radio Frequency Measurement," 2d ed., p. 447, Charles Griffin & Company, Ltd., London, 1931.
2. WOODRUFF, L. F.: "Electric Power Transmission and Distribution," p. 224, John Wiley & Sons, Inc., New York, 1928.
3. EVERITT, W. L.: "Communication Engineering," pp. 265-266, McGraw-Hill Book Company, Inc., New York, 1932.
4. EVERITT, W. L.: "Communication Engineering," p. 273, McGraw-Hill Book Company, Inc., New York, 1932.
5. BRUDERLIN, HENRY: Like a Kitten in a Soundproof Sleeper, *Aviation*, March, 1937.
6. FLETCHER, H.: Interpretation of Speech, *Jour. Franklin Inst.*, Vol. 193, p. 6, June, 1922.

APPENDIX

MECHANICAL REQUIREMENTS FOR AIRCRAFT RADIO EQUIPMENT

A. WIRING

1. All low-level audio-frequency wiring shall be run in twisted two-conductor shielded cable where necessary. All microphone and headphone circuits shall be two-wire, balanced to ground. It is not permissible to ground one side of any headphone or microphone circuit.
2. All wiring shall be color coded. The color-coding scheme shall conform to the standards of the R.M.A. in so far as they apply.
3. All connections to parts inside shielding cans should be so arranged that the can may be removed for inspection of the parts inside, without the necessity of threading connecting leads through holes in the can. It is permissible to unsolder a lead from a stud in order to accomplish this. Receiver-tube grid leads may be threaded through a hole in a can.
4. Solid wire may be used provided that it is supported at intervals not to exceed $1\frac{1}{2}$ in. Wherever flexing will be encountered, stranded, tinned, pushback wire made of at least five strands and having a combined area not smaller than No. 20 B. & S. gauge shall be used.
5. All wire carrying less than 300 volts shall withstand a 500-volt insulation breakdown test, after being subjected to moisture, bending and vibration. It shall be capable of giving 5 years of service in aircraft. Wire for higher voltages shall be approved by the buyer.
6. Where wiring passes through metal, it shall be fully protected by use of fiber grommets. Rubber grommets of the highest quality may be used only with the buyer's approval.
7. Wiring cables shall be supported by clamps at intervals of not less than 6 in. unless otherwise secured by soldered ends, grommets, etc.
8. Grid wire and all high-impedance leads, unless rigidly supported to the structure, shall be covered with two layers of varnished cambric tubing which shall extend over the solder lugs of both ends of the wire.
9. Fireproof wire shall be used wherever practical.

B. RESISTORS

1. All fixed resistors shall be mounted on terminal boards.
2. No resistors shall be supported by pigtailed, except when the pigtailed hold down the resistors flat on a board.

3. The maximum wattage dissipated in any resistor shall not be more than three fourths of the manufacturer's rating. In any case, the maximum wattage dissipated in the resistor shall not be more than three-fourths that wattage which will give normal resistor life.
4. Resistors that dissipate a substantial amount of heat shall be spaced adequately from other parts to prevent damage.
5. In the case of large resistors, mounting shall be provided which will adequately protect the resistors from breakage due to mechanical shock.

C. CAPACITORS

1. All paper by-pass condensers subjected to 250 volts or less shall carry a manufacturer's working voltage rating of 400 volts. Where subject to greater than 250 volts, the condenser shall be test rated to 50 per cent higher than the greatest voltage that will appear.
2. All paper condensers shall be metal cased and sealed from moisture and shall have soldering lugs.
3. The wax used in condensers shall not flow at any temperature up to 160°F.
4. All mica condensers shall be of 500 volts test rating when the combined peak alternating and direct voltage is not more than 250 volts. When the combined alternating- and direct-current peak potential to which such condensers are subjected exceeds 250 volts, the manufacturer's test rating shall be at least twice the voltage that is actually applied to the condenser.
5. Condensers shall be mounted securely. They shall not be mounted by means of their leads, except in the case of mica condensers of the "postage-stamp" size, which may be lead supported when the condenser is held flat against a terminal board. In this case, the length of lead from the condenser to the terminal-board securing hole shall not exceed $\frac{1}{4}$ in.
6. A self-cleaning, noiseless method of making contact between the rotor and the case of variable condensers shall be used. No pigtailed shall be used on variable condensers.
7. Microphonic noise from condenser plates shall not be detectable in the headphones or visual indicator with the receivers adjusted to maximum sensitivity and subjected to vibration in an airplane. It is estimated that the equipment rack shock mounting will attenuate the airplane vibration amplitude by 20 db.
8. Microphonic noise shall not be detectable in the modulated or unmodulated output of transmitters when subjected to vibration in an airplane.
9. Trimming condensers shall be of the air dielectric type and shall be provided with suitable and positive locking devices. The locking devices shall be so arranged that they will automatically indicate whether they are in the locked or unlocked position. No mica padders of any type shall be used in receiver-tuned radio-frequency

circuits unless they are fixed and sufficiently temperature compensated to prevent receiver output voltage changing more than 50 per cent under -40 to $+160^{\circ}\text{F}$. temperature changes. Friction locks may be used only on very small air condensers.

10. Variable condensers that normally are not adjusted in flight shall be equipped with a positive locking means, as well as a pointer, to indicate approximate position. The means adopted shall be such that a quick visual inspection will reveal whether or not the condenser is locked.
11. No electrolytic or other type condensers shall be used where the lowering of capacitance, due to temperatures as low as -40°F ., will noticeably affect the operation of any part of the equipment. Electrolytic condensers shall be rated for a 50 per cent higher voltage than appears in the circuit in which they are used.
12. Liquid or semiliquid filled condensers shall not be used in an inverted position unless their manufacturer specifies that the condensers have no positional limitations. This limitation does not apply to so-called dry electrolytic condensers.
13. Condensers carrying radio-frequency currents shall not exhibit more than a 40°C . rise when operated on a 15-min. on, 30-min. off basis. The ambient temperature shall be 160°F . first cycle and 132°F . for the remaining cycles.

D. MECHANICAL

1. The chassis may be made of simple lightweight castings, extruded shapes, or bent aluminum shapes with strength and stiffness factors equal to castings. Chassis parts, where practical, shall be used in a manner that will permit easy disassembly so as to allow access to parts for major rewiring, etc.
2. The distance from the bottom of any main equipment unit to the subpanel on which equipment is mounted shall not exceed 4 in.
3. Where possible, all equipment should be mounted on the subpanel, and no equipment should be mounted on the sides of the chassis.
4. Parts shall not be stacked one upon the other. Each part shall be removable without disturbing any other part.
5. The chassis shall be dust-tight with respect to units affected by dust. It is permissible to have high-temperature units such as resistors in exposed places of improved ventilation.
6. Wherever machine screws are used to hold parts together, they shall work into metal of ample thickness to ensure permanency of the threads.
7. All nuts and bolts shall use standard threads (4-40, 6-32, 8-32, 10-32). No self-tapping screws shall be used. Aluminum and duralumin screws and nuts shall not be used without specific approval.
8. The insulating material of the sockets shall be sufficient to prevent any appreciable leakage in moist air conditions and shall not be subject to cold flow.

9. The socket contacts shall be attached to the socket in a manner that will make it impossible for the contact to turn from its normal position directly below the prong hole.
10. Positive locks shall be provided for tube sockets carrying tubes of the physical size of the type 210 or larger. All tubes with composition bases, except receiver tubes, shall be locked into the socket by some means other than their bayonet pins.
11. No ground connections shall be made through rivets.
12. All parts shall be held together with machine screws in such a manner that any part may be removed without the removal of other near-by parts.
13. The rivet-head type of nut shall be used so that machine screws may be removed without holding the nut.
14. Nuts shall be soldered to their machine screws on those assemblies which are replaced as a unit and parts of which are not salvaged.
15. No soldering point shall be crossed by wires so that there is danger of burning the insulation from such wires when soldering the joint.
16. No part shall be so placed that it will harm adjacent parts or wiring due to overheating or chafing.
17. Radio manufacturers shall provide suitable test limits and instructions so that the buyer may know when and how to replace dry-disk rectifiers and other units that age considerably.
18. Ceramic insulating material shall be mounted so that destructive strain cannot be placed on the material during normal assembly or service.
19. Whenever possible, standard, nationally known and distributed parts shall be used. The number or kinds of parts and the number of part types and ratings shall be kept to a minimum.
20. Plug and relay contacts shall be easy to inspect and readily accessible for cleaning.
21. It shall be easy to solder wiring at the back of plugs without moving other wires.
22. Wiring diagrams shall show the symbol for each part, the manufacturer and his type designation of that part, and the rating of the part.
23. A parts list shall be provided for each major equipment unit, which shows the function of the part in the circuit and ordering information.
24. A blueprint clearly showing the position of all tubes by type number shall be fastened in the cover of all major equipment units.
25. The function of all tuning adjustments shall be suitably marked. Arrangements shall be made for sealing these adjustments.
26. The plugs chosen by the seller shall be submitted to the buyer for approval. Power plugs mounted on front panels shall be equipped with extraction locking rings.
27. Telephone type relays are undesirable and, if used, shall operate at twice normal contact pressure. All relays used shall be approved by the buyer.

28. Cadmium plating shall be used on all metal parts except aluminum and duralumin and except those subject to wear from handling. Nickel plating shall be used on items subject to wear due to handling. No bearing surface shall be plated.
29. Mechanical-shift mechanism bearings shall be sufficiently large so that they will not allow undue slack after 5 years of use. Steel or bronze bearings are preferable.
30. With the exception of bearings such as those that occur on variable condensers and roller contact coils, all bearings shall be of dissimilar metals.
31. All antenna trimmers shall be accessible from the front of the unit.
32. All soldering shall be done with rosin flux only.
33. The manufacturer shall supply one copy of instruction books per set of equipment.
34. The manufacturer shall provide each unit with a serial number stamped directly into the metal of the chassis or on a name plate permanently affixed thereto. The manufacturer shall also provide a suitable patent plate. The name plate and patent plate may be combined. The serial number must be capable of being easily read when the equipment is in its mounting rack.
35. The desired serial numbers to be stamped on the plates shall be in accordance with the buyer's designation.
36. Wherever metal parts are fastened together, they shall be clean and bright and make good electrical contact.
37. Units such as sockets, condensers, and transformers, which are replaceable on failure, shall not be held to the chassis by means of rivets.
38. The rear of the chassis shall be provided with adequate protection against scuffing such as that which occurs when it is dragged over concrete.
39. The chassis cover shall be provided with a means for preventing scuffing of its edges when the receiver is inserted in a mounting rack.
40. If crystals are to be used, the holder shall be provided with a retaining clamp. This crystal clamp shall be approved by the buyer.

E. GENERAL TEST REQUIREMENTS

1. The equipment shall bear a CAA approved-type certificate.
2. Misadjustment of circuits occurring during service procedure shall not result in damage to any parts (other than tubes) due to overheating or excessive voltage when operated in such condition for a period up to 15 min.
3. All equipment shall be thoroughly stable in operation regardless of the condition of the tubes used, provided that tubes are neither defective nor have dropped below their normal rejection point.
4. The performance of the equipment shall not vary appreciably upon substituting any good tube of the type used.

5. Tubes need not be operated within their published ratings; however, if manufacturers intend to operate tubes above published ratings, they shall so state.
6. Transformer windings shall not be damaged by A.I.E.E. standard transformer test procedure.
7. The tuning of transmitters and the alignment of receivers shall be made as simple as possible. Special credit will be attached to a reduction in the number of adjustment controls.

F. IMPREGNATION

1. Samples of each general type of fixed condensers, resistors, and impregnated coils (outside of their own container) shall not be affected materially by submersion in sea water for 24 hr. at 132°F., and power transformers and wiring cables shall not be affected materially by being subjected for 72 hr. to 95 per cent humidity at 132°F. Before making the tests after submersion, their exteriors may be dried.
2. Audio transformers, chokes, coils, and similar parts shall be mounted in metal containers. Impregnation compound shall be used in these containers to exclude all moisture. This requirement may be waived if sufficient weight saving can be shown.
3. Impregnation compound, wherever used, shall not be subject to flow at ambient temperatures as high as 160°F. This requirement shall not be interpreted as applying to cold flow. In no case shall compound drip at 132°F. ambient with equipment operating.

G. MAINTENANCE PROVISIONS

1. When a time for the removal of a chassis from a mounting rack is specified, the time shall start when the mechanic is in place in the airplane at the equipment, ready to start removal. When the time for the replacement of parts in a chassis is specified, the time shall start when the chassis is on the workbench and shall include the time for dust-cover removal and reattachment.
2. Any chassis shall be removable from a mounting rack in the airplane within $\frac{1}{2}$ min. No tools shall be required for such removal.
3. The dust cover on any chassis shall be removable in 1 min.
4. It shall be possible to replace any fixed resistor or fixed condenser within 7 min.
5. It shall be possible to replace any tube socket within 10 min.
6. It shall be possible to replace any other part within 15 min.
7. The alignment of trimmers shall be made simple, and it shall be possible for trained personnel with adequate test equipment to completely align any receiver within 10 min.
8. Except for plugs, it shall be necessary to remove only two thumb-screws or their equivalent in order to remove any receiver chassis from a mounting rack.
9. All main equipment units shall be designed so that they can be laid on the bench on either end, front or back, or top or bottom without

damage to the equipment, their weight to be supported by amply heavy structure.

10. All trimmers except those for the antenna should be adjustable from the top of the chassis. In any case, it shall not be necessary to invert the unit to reach trimmers.

H. MOUNTINGS

1. The dimensions of the units shall be in accordance with Figs. 224, 225, and 226 or approved multiples of the dimensions shown on these figures.
2. The mechanical design of all major equipment units shall be such as to permit the mounting of all units in one or more compact racks. It shall also be possible to mount each unit in an individual rack. The racks, whether used for individual units or a number of units, will be shock mounted and will normally remain in the airplane. No major equipment unit itself will be shock mounted.
3. The sizes of units, wiring hose, and attaching plugs, as well as a system for securing apparatus units in the racks, shall be as shown in Figs. 227 and 228.
4. The apparatus for securing the equipment in the rack shall be so constructed that it will not rattle under airplane vibration.

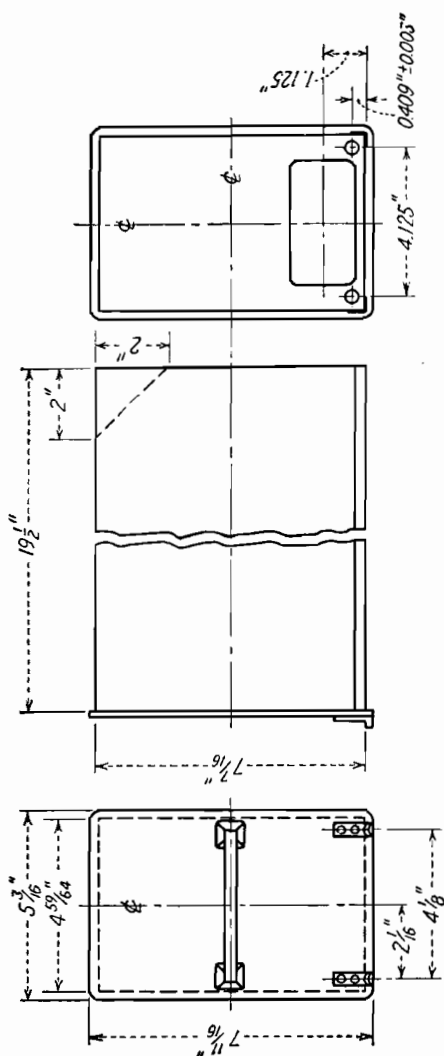

Fig. 224.—Standard size for commercial aircraft radio equipment. This size is known as a one-half ATR unit. (Courtesy of Aeronautical Radio, Inc.)

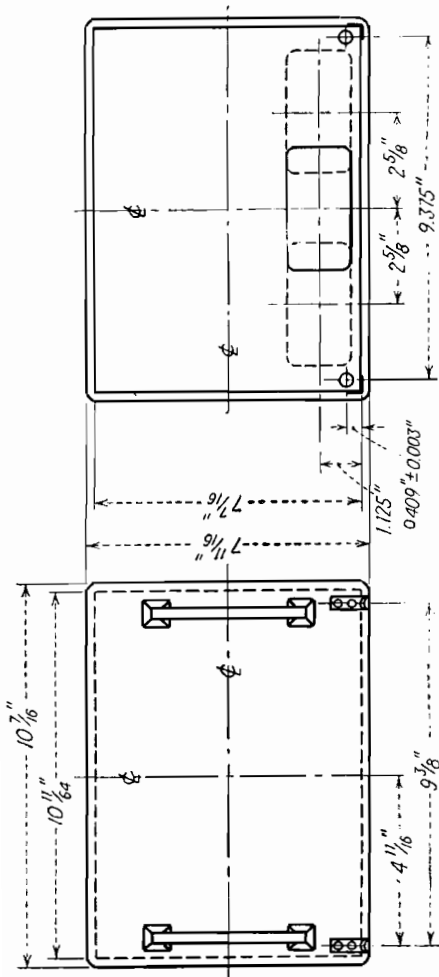

FIG. 225.—Standard size for commercial aircraft radio equipment. This size is known as one ATR unit. Notice that while all other dimensions are the same as those shown for the unit of Fig. 224, the width is twice as large. (Courtesy of Aeronautical Radio, Inc.)

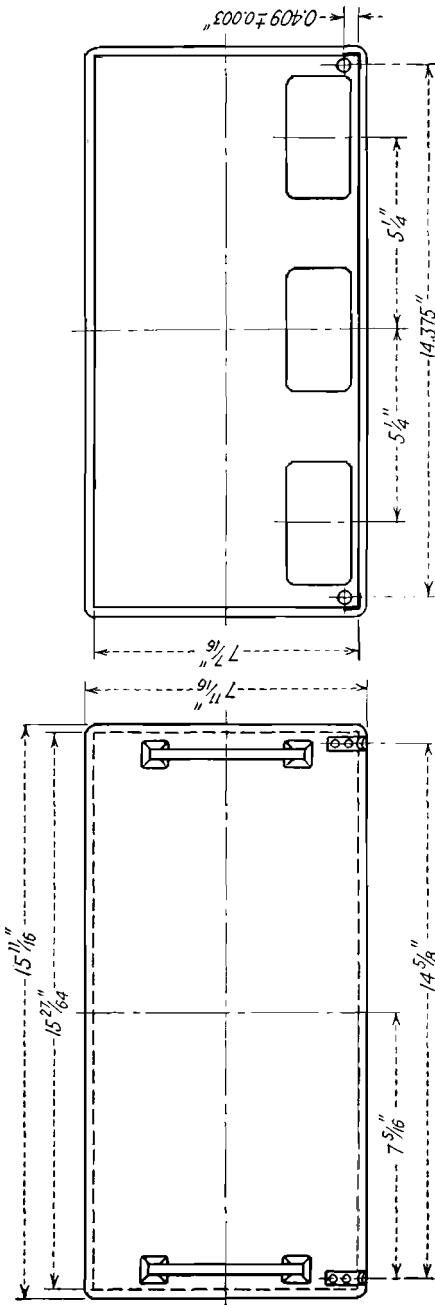

FIG. 226.—Standard size for commercial aircraft radio equipment. This size is known as a one and one-half ATR unit. (Courtesy of Aeronautical Radio, Inc.)

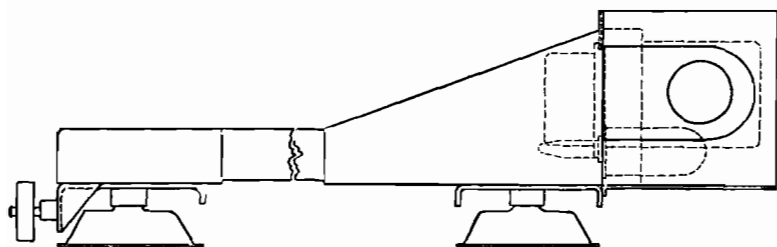

FIG. 227.—Standard mounting for transport aircraft radio equipment. (Courtesy Aeronautical Radio, Inc.)

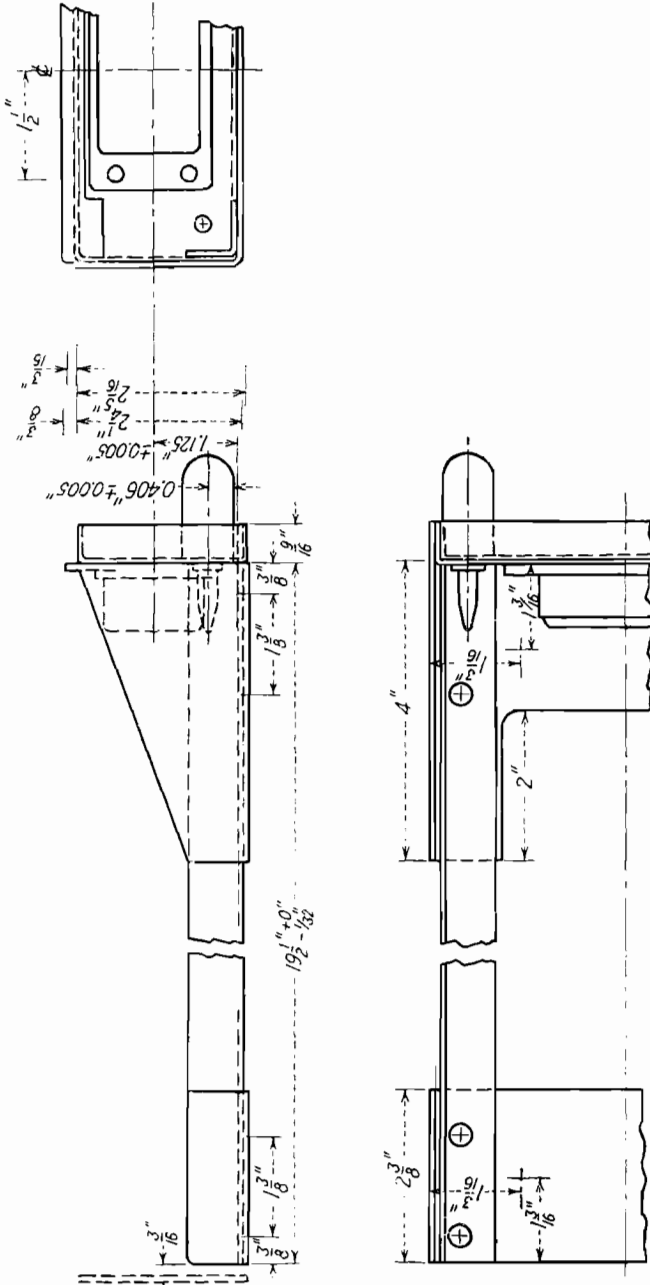

FIG. 228.—Further details of mounting for transport aircraft radio equipment. (Courtesy of Aeronautical Radio, Inc.)

INDEX

A

- Abnormal polarization, definition, 229
effect, on Adcock direction finders, 240
on loop direction finders, 234
on spaced loops, 243
- Absolute altimeters, capacity, 208
definition, 198
need for, 199
radio, 211
sonic, 199
- Accessibility of radio equipment, 10
- Adcock direction finder, error caused
by abnormal polarization, 241
minimum signal error, 249
principle of, 236
unbalanced current effects, 246
- Adjacent channel interference, 296
- Aircraft communications antennas, 275
calculating characteristics of, 277
electrical characteristics of, 281
fixed-wire, 277
short trailing wire, 276
shunt-excited, 277
trailing-wire, 275
- Aircraft direction finders, automatic, 131
Busignies, 134
errors, quadrantal, 142
when using range stations, 137
simple type, 127
- Aircraft generators, common type, 333
newer types, 336
- Aircraft indicators, 9, 382
- Aircraft power supply systems, alternating current, 340
- Aircraft power supply systems, common type, 330
growth of electrical demand, 328
how related to radio systems, 328
variable frequency, 344
- Aircraft systems, introduction to, 8
- Aircraft transmitter, frequency-changing methods, 289
other design considerations, 290
output-circuit design, 285
- Alford loop, 85
as an ultra-high-frequency range receiving antenna, 100
use with aural ultra-high-frequency range, 87
- Aneroid altimeter, 198
- Antenna, receiving, for Bendix-United instrument landing system, 182
effect on cone of silence, 147
effect on fan and Z markers, 157
- Antenna systems, 352
- Antennas, for aircraft communications, 275
(See also Aircraft communications antennas)
for Bendix-United instrument landing transmitter, 177
for Bureau of Standards glide path, 174
for fan markers, 156
for ground-station communication, 300
(See also Ground-station antennas)
for low-frequency range receiving, 66
for receiving microwave markers, 165

- Antennas, for receiving ultra-high-frequency markers, 157
 for simple horizontally polarized ultra-high-frequency range, 83
 for simple vertically polarized ultra-high-frequency range, 84
 for ultra-high-frequency airplane communications, 310
 for ultra-high-frequency ground station, 324
 for ultra-high-frequency range receiving, 100
 for Western Electric Company altimeter, 222
 for Z marker, 152
- Attenuation factor for plane earth, 260
- Audio characteristics of range receiver, 65
- Audio output, level, 369
 systems, 366
- Audio switching, 372
- B
- Bearing errors, of aircraft direction finders, 137, 142
 of ground-station direction finders (see Source of errors in ground-station direction finders)
- Bendix-United instrument-landing system, 176
- Bonding (see Noise suppression)
- Bureau of Standards instrument-landing system, 174
- C
- Capacity altimeter, 208
 Gunn type, 209
 magnitude of capacity, 209
 results of development, 211
- Cardioid field pattern, of a loop and vertical antenna, 126
 of an omnidirectional range, 93
- Communications (see Medium-high frequency; Ultra-high frequency)
 between ground stations, 269
- Communications, receiver, 5
 systems, 5
 transmitter, 5
- Compass, magnetic, as an avigational device, 1
- Conduits for electrical systems, 335
- Cone of silence, 146, 147
 objections as a marker, 149
- Cone-of-silence pattern, 147
 effect, of near-by objects, 148
 of receiving antenna, 148
- Control units, cockpit, 382
- Course, rotation, 36
 shifting and bending, 40
- Course aberrations, bending, 72
 caused by loop antennas, 107
 multiples, 75
- Critical frequency, 268
- Current-limiting relay, 333
- D
- Deviation of airplane from true course, 2
- Dielectrics, effect of moisture on, 13
- Direction finders (see Aircraft direction finders; Ground-station direction finders)
- Drop test, 17
 effect on radio equipment, 17
- E
- Effective height, of low-frequency receiving loop antennas, 119
 of low-frequency transmitting loop antennas, 31
- Equipment failure, 7
 design considerations, 9
- F
- Fading, causes of, 231
 of communications signals, 269
 effect on accuracy of ground-station direction finders, 245
- Fan markers, 153
 need for, 154

- Field pattern, of Alford loop on airplane, 101
 of aural ultra-high-frequency range, 87
 of communications antenna, 283
 definition of, 25
 equation for low-frequency loop, 25
 of low-frequency aural radio range, 29
 of low-frequency visual radio range, 57
 of visual ultra-high-frequency range, 90
- Field strength, calculation, for airplane signals, 259
 for low-frequency range, 59
 from low-frequency range loop, 36
 minimum for satisfactory communication, 265
 of an ultra-high-frequency range, 95
- Filters, for simultaneous range reception, 56
 for suppressing image frequency, 99
- Fix, 128
- Forced draft for radio equipment, 14
- Frequencies, for alternating-current electrical systems, 341
 for communications, 275
 for markers, 151
 for radio altimeter, 217
 for radio range, 31
 for ultra-high-frequency communications, 308
 for ultra-high-frequency range, 90
- Frequency channels, utilization of, for communications, 293
- Frequency selector units, 382
- Fuses, 335

G

- Generators (*see Aircraft generators*)
- Geographical coverage, of low-frequency radio range, 59
 of ultra-high-frequency radio range, 95

- Glide path, 169
 Bureau of Standards, 169
 C.A.A.-I.T.D., 186
 C.A.A.-M.I.T., 192
 calculation of, 170
 control of shape, 184
 shape of, 172
- Goniometer, adjustment for maximum course stability, 52
 installation in aural range station, 57
 use, for range course rotation, 36
 with ground-station direction finder, 238
- Ground-station antennas, common types, 300
 directionals, 302
 practical limitations, 301
- Ground-station communications receivers, local type, 300
 number of frequencies, 298
 remote operation of, 299
- Ground-station direction finders, Adcock, 236
 Pan-American system, 253
 spaced loop, 242
 United Air Lines system, 255
 Western Electric system, 254
- Ground-station direction finding, need for, 225
 problems of, 226
 requirements, 226
- Ground-station installations, characteristics of, 22
 considerations in, 22
- Ground-station transmitter, adjacent channel interference, 296
 location of, 295
 method of providing multifrequency operation, 295
 number of frequencies, 293
 power of, 296

H

- Handles on aircraft radio equipment, 10
- Headphones, 392

High-impedance loops, comparison with low-impedance loops, 126
 Humidity, from wet- and dry-bulb thermometers, 13
 Humidity test, 11

I

Indicators, for automatic direction finder, 132
 for Bureau of Standards instrument-landing system, 175
 for C.A.A.-M.I.T. instrument-landing system, 195
 for low-frequency visual radio range, 58
 for radio compass, 129
 Installation of aircraft direction finders, 142
 Instrument landing, history of, 168
 need for, 168
 principles of all systems, 169
 Instrument-landing systems, Bendix-United, 176
 Bureau of Standards, 174
 C.A.A.-I.T.D., 186
 C.A.A.-M.I.T., 192

Interphone systems, 373
 Inverse current relay, 333, 336
 Ionosphere, in aircraft communications, 269
 characteristics of, 266
 Ionosphere waves, characteristics of, 227
 fading of, 230
 path deviation, 231
 polarization, 228
 predicting behavior of, 270
 scattering, 232

L

Localizer, 385
 Loop, low-frequency transmitting, dimensions of range type, 31
 effective height of, 31
 field pattern of radio range, 24
 inductance of, 32

Loop, low-frequency transmitting, resistance of, 35
 ultra-high frequency (*see* Alford loop)

Loop antennas, high impedance, 120
 low-frequency receiving type, effect on precipitation static, 107, 108

low impedance, 122
 principles, 110
 shielded, 118

M

Markers, for Bendix-United instrument-landing system, 180
 for Bureau of Standards instrument-landing system, 174
 for C.A.A.-I.T.D. instrument-landing system, 191
 for C.A.A.-M.I.T. instrument-landing system, 194
 cone, 146
 fan, 153
 microwave, 164
 other 75 megacycles, 156
 z-type, 150

Medium-high-frequency communications, history, 257
 need for, 257
 practices, 258

Medium-high-frequency direction finders, 253
 (*See also* Ground-station direction finders)

Microphones, 390

Modulation, control for aircraft transmitter, 363
 control for ground-station transmitter, 297
 of transmission by propellers, 313
 type of for ultra-high-frequency communications, 309

Moisture, effect on ultra-high-frequency range antenna, 89
 effect on ultra-high-frequency receiving antenna, 102

Monitor for C.A.A.-I.T.D. instrument-landing system, 191

N

- Network for Alford loop, 102
- Night effect with radio ranges, 43
- Noise in cockpit, 391
- Noise suppression, 349

O

- Omnidirectional range, principle of operation, 92
 - RCA type, 93
- Optical path of radio waves, 93
- Output-circuit design for, aircraft transmitter, 285
 - TL range, 48
- Overloading of radio range receiver, 66

P

- Path deviation, effect on direction-finding accuracy, 231
 - magnitude of, 232
- Phase, alternating-current system, 343
- Polarization of radio waves, in Bendix-United instrument-landing system, 178
 - effect on direction finding, 228
 - (See also Abnormal polarization)
 - effect on ultra-high-frequency range, 82
 - for ultra-high-frequency communications, 309
- Power output of transmitter under humidity test, 12
- Power supply systems, 328
 - (See also Aircraft power supply systems; Systems for aircraft radio power)
- Power unit for Western Electric Company altimeter, 222
- Precipitation static, 106
 - causes of, 107
- Pressure, effect on radio apparatus, 19

- Pressure, effect on sonic altimeter accuracy, 205
 - test, 18
- Prime movers, 343

Q

- Q of coils, effect of moisture, 12
- Quadrantal error, 143
 - correction for, 143

R

- Radio altimeters, 211
 - Alexanderson, 212
 - early types, 211
 - Western Electric, 214
- Radio compass, 128
- Radio echoes, types of, 234
- Radio range, aural low frequency,
 - characteristics of, 29
 - course, 30
 - history, 24
 - installation, 7
 - principles of, 29
 - as road, 3
 - simultaneous type, 53
 - TL type, 45
 - U.S. system, 31
 - (See also Omnidirectional radio range; Ultra-high-frequency range; Visual radio range)
- Radio range course, 30
 - intersection as marker, 146
- Radio road, 3
 - (See also Radio range)
- Range filter, characteristics of, for low-frequency simultaneous use, 55
- Receivers, aircraft communications, 291
 - Bendix-United instrument landing, 180
 - Bureau of Standards glide path, 175
 - C.A.A.-I.T.D. glide path, 187
 - C.A.A.-I.T.D. localizer, 191

- Receivers, C.A.A.-M.I.T. instrument landing, 194
 ground-station communications, 298
 (See also Ground-station receiver)
 low-frequency radio range, 62
 radio compass, 138
 75-megacycle marker, 160
 ultra-high-frequency communications, 321
 ultra-high-frequency ground station, 324
 ultra-high-frequency range, 97
 Western Electric Company altimeter, 219
- Relays, antenna, switching, 354
 transmitting, 359
 brush lifting, 380
 high voltage, 361
 system, 361
- S
- Scattering, 232
 causes of, 234
 effect on bearings, 232
- Sensitivity of receivers under humidity tests, 12
- Service, equipment, 21
 organization, 19
 personnel for aircraft equipment, 20
 procedure for aircraft radio, 19
 shops, 21
- Shielding, 350
 (See also Noise suppression)
- Shock mounting, 10
- Signals from airplanes, characteristics of, 264
- Sonic altimeters, commercial availability, 208
 distance indicators, 202
 errors in, 205
 limitations of, 206
 performance of, 207
 sound detectors, 201
 sound generators, 199
- Sound power for sonic altimeter, 207
- Source of errors in ground-station direction finders, diversity, 246
 instrument, 252
 minimum signal, 249
 other ionosphere-propagated wave characteristics, 244
 polarization, 240
 terrain, 250
 unbalanced currents, 246
- Space patterns of antennas (see Field pattern)
- Spaced-loop direction finder, 242
 effect of abnormally polarized waves on, 243
 minimum signal errors, 249
 unbalanced-current effects, 246
- Split headphones, 386
- Stability of receivers, C.A.A.-I.T.D.
 glide path, 187
 marker, 163
- Switches for aircraft electrical systems, 335
- Systems for aircraft radio power, direct-driven generator, 380
 dynamotor, 381
 individual and common dynamotors, 381
 vibrator converter, 381
 wind-driven generator, 379
- Systems for aircraft transmitters, 357
 applying filament power, 357
 applying plate power, 361
 audio for the transmitter, 362
 connecting antenna, 358
 silencing the receiver, 360
 stopping the transmission, 365
- Systems for audio output, dual stages, 368
 high level, 369
 hybrid coil, 366
 low level, 369
 segregation by resistors, 366
- Systems at major air terminals, 386
- Systems for remote carrier control, simplex, 389
 tone, 389

- Systems for small ground stations, 384
- Systems engineering, 348
- T
- Telephony, radio, use of, 5
- Temperature, effect, on circuit elements, 14
 on crystals, 14
 on tuning, 13
 specification, for glide-path receiver, 187
 for ultra-high-frequency ground-station transmitter, 323
- test, 12
- Terrain, electrical characteristics of, 62
- Test, C.A.A., aircraft radio equipment, 10
- Testing marker receivers, 162
- Testing radio compasses and direction finders, I.R.E. standards, 140
- U.S. Army method, 140
- Towers, range, characteristics of, 46
 construction, 47
 effective height, 47
 resistance, 47
- Trailing-wire discharger, 108, 109
- Transformers, for coupling low-impedance loop, 122
 for low-frequency range receiving antennas, 69
- Transmitters, aircraft, 289
 (See also Aircraft transmitter)
- aural loop-type ultra-high-frequency range, 87
- Bendix-United instrument landing, 179
- Bureau of Standards glide path, 174
- C.A.A.-I.T.D. glide path, 186
- C.A.A.-I.T.D. localizer, 191
- C.A.A.-M.I.T. instrument landing, 194
- fan marker, 155
- Transmitters, ground communications, 293
 (See also Ground-station transmitter)
- simple ultra-high-frequency range, 85
- simultaneous range, 56
- ultra-high-frequency aircraft, 320
- ultra-high-frequency ground station, 323
- Z marker, 151
- U
- Ultra-high-frequency airplane communications antenna, series type, 310
 shunt type, 311
 space patterns of, 313
- Ultra-high-frequency communications, airplane antenna, 310
- airplane receiver, 321
- airplane transmitter, 320
- ground-station antenna, 324
- ground-station receiver, 324
- ground-station transmitter, 323
- microwave communication, 326
- need for, 307
- transmission anomalies, 317
- use of, 308
- Ultra-high-frequency range, aural type, using loop, 87
 simple type, 83
- tests in mountainous country, 78
- visual two-course ultra-high-frequency, 90
- Unbalanced-current effects, in a low-frequency receiving loop, 116
 method of compensation, 117
- V
- Vertical antenna, ultra-high-frequency range array, 84
 use to shift range courses, 42
- Vibration, effect, on radio apparatus, 15
 on relays, 15
- test, 14

Visual radio range, principle of, 56
two-course ultra-high-frequency, 90

Voltage, aircraft electrical system, alternating current, 343
common, 330
optimum, 337
variable frequency, 346

induced in loop antenna, 112
output of loop antennas, 119
phase of, induced in a loop, 115

Voltage regulator, common type, 333
new type, 336

Volume controls, 383

W

Weight, aircraft communications receiver, 293

aircraft communications transmitter, 291

automatic direction finder, 140

C.A.A.-I.T.D. glide-path receiver, 188

capacity altimeter, 211

common aircraft generator, 333

DC-3 electrical system, 336

limit, 10

low-frequency range receiver, 65

marker receiver, 164

prime movers, 344

Weight, requirements of aircraft radio equipment, 10

sonic altimeter, 207

storage battery, 333

transformers, 341

24-volt electrical system, 337

ultra-high-frequency aircraft-communications unit, 323

ultra-high-frequency range receiver, 100

variable-frequency system, 346

Western Electric Company altimeter, 223

Western Electric Company altimeter, antennas, 221

description, 217

history, 214

performance, 222

power unit, 221

principle, 215

receiver, 219

testing, 222

transmitter, 218

Wire, common type, 334

effect of humidity on, 11

Z

Z marker, 150

effect of atmospherics on, 151

Z marker pattern, 150

change with sensitivity, 151